

LA-5651-M, Suppl.
Manual

c. 2

Special Distribution
Reporting Date: February 1975
Issued: February 1975

**Fundamentals of Passive Nondestructive
Assay of Fissionable Material:
Laboratory Workbook**

by

T. D. Reilly
R. H. Augustson
J. L. Parker
R. B. Walton
T. L. Atwell
C. J. Umbarger
C. E. Burns



DO NOT CIRCULATE

**PERMANENT RETENTION
REQUIRED BY CONTRACT**

**Los Alamos
scientific lab**

of the University of California
LOS ALAMOS, NEW MEXICO 87544

An Affirmative Action/Equal Opportunity Employer



In the interest of prompt distribution, this manual was not edited by the Technical Information staff.

This report was prepared as an account of work sponsored by the United States Government. Neither the United States Energy Research and Development Administration, nor any of their employees, nor any of their contractors, subcontractors, or their employees, makes any warranty, express or implied, or assumes any legal liability or responsibility for the accuracy, completeness or usefulness of any information, apparatus, product or process disclosed, or represents that its use would not infringe privately owned rights.

TABLE OF CONTENTS

Laboratory No. 1.	BASIC GAMMA-RAY EXPERIMENT	1
Laboratory No. 2.	SUGGESTED PROCEDURE FOR PLUTONIUM ASSAY WITH NaI DETECTOR AND PORTABLE ELECTRONICS	13
Laboratory No. 3.	URANIUM ENRICHMENT MEASUREMENTS	21
Laboratory No. 4A.	MEASUREMENT OF EQUIPMENT HOLDUP	31
Laboratory No. 4B.	MEASUREMENT OF LARGE-VOLUME AIR FILTERS	45
Laboratory No. 5.	NEUTRON DETECTION WITH PORTABLE INSTRUMENTATION	51
Laboratory No. 6.	TOTAL NEUTRON COUNTING OF PLUTONIUM AND URANIUM SAMPLES	61



FUNDAMENTALS OF PASSIVE NONDESTRUCTIVE ASSAY OF FISSIONABLE MATERIAL:
LABORATORY WORKBOOK

by

T. D. Reilly, R. H. Augustson, J. L. Parker, R. B. Walton,
T. L. Atwell, C. J. Umbarger, and C. E. Burns

ABSTRACT

This workbook is a supplement to LA-5651-M, "Fundamentals of Passive Nondestructive Assay of Fissionable Material" which is the text used during the Nondestructive Assay Training Session given by Group A-1 of the Los Alamos Scientific Laboratory. It contains the write-ups used during the six laboratory sessions covering basic gamma-ray principles, quantitative gamma-ray measurements, uranium enrichment measurements, equipment holdup measurements, basic neutron principles, and quantitative neutron assay.

LABORATORY NO. 1

BASIC GAMMA-RAY EXPERIMENT



Fig. 1.1. Physical setup of Laboratory 1.

I. EQUIPMENT

- A. Oscilloscope
- B. Multichannel pulse-height analyzer
- C. Ge(Li) detector and amplifier
- D. NaI detector and amplifier
- E. Eberline SAM I or II with 5.08- by 5.08-cm NaI probe
- F. Assorted sources and shield material

II. EQUIPMENT OPERATION (45 min for II)

A. Oscilloscope Operation

The oscilloscope is a very useful instrument for setup and checkout of nuclear counting systems. It enables the assayist to check the output pulses from the system, adjust system gain, and get a rough idea of the gamma spectrum incident on the detector. Its operation should be familiar to the nuclear assayist. A small portable scope is a highly recommended accessory to any nuclear assay system. You should understand the operation of the scope and be able to adjust the vertical gain (V/cm), sweep time ($\mu\text{s}/\text{cm}$), and trigger controls to get a proper display. The instructor will give a brief explanation of oscilloscope operation and will help you gain familiarity with the controls throughout the course of this lab session.

B. Multichannel Analyzer (MCA) Operation

This is a more expensive piece of equipment and less likely to be available for portable operations. The instructor will explain the principle of operation of the MCA and will help you gain familiarity with the controls throughout the course of this lab session.

III. Ge(Li) AND NaI GAMMA-RAY SPECTRA--DEMONSTRATION (45 min for III)

A. Ge(Li) Spectra

Hold a ^{137}Cs (662 keV) in front of the Ge(Li) detector. Observe the resulting pulse-height spectrum in the MCA and scope. Be sure you understand the meaning of the peak in the MCA and the bright band in the scope. Change the amplifier gain control. What effect does this have? _____

B. Energy Calibration

Hold ^{137}Cs and ^{57}Co sources in front of the detector. Record the peak positions (channel no.) of these two sources:

$$122 \text{ keV} = \text{chan. no.} \quad \underline{\hspace{2cm}} \quad (X_1)$$

$$661.6 \text{ keV} = \text{chan. no.} \quad \underline{\hspace{2cm}} \quad (X_2)$$

Compute the parameters in the calibration equation [Eq. (2.2) in the Manual]

$$E = \underline{\hspace{1cm}} X + \underline{\hspace{1cm}}$$

$$m = \frac{661.6 - 122}{X_2 - X_1} = \underline{\hspace{2cm}}$$

$$b = 122 - mX_1 = \underline{\hspace{2cm}}$$

C. Detector Resolution

Measure the full width at half maximum (FWHM) of the ^{137}Cs peak (this is a rough measurement because there is only a small number of channels in the peak).

$$\text{FWHM (662 keV)} = \underline{\hspace{1cm}} \text{ chan} = \underline{\hspace{1cm}} \text{ keV}$$

D. Exercises

Compare the cesium spectrum with Fig. 2.1 in Manual. Be sure you understand the various features listed: photopeak, Compton edge, backscatter peak, etc. What causes the observed counts between the Compton edge and the photopeak?

What causes the counts above the photopeak? _____

Hold up a ^{235}U foil. Determine the energy of prominent gamma (γ) rays.

Hold up a 10% enriched uranium sample. Observe the γ -ray activity from ^{238}U daughters. Determine the energy of prominent gamma rays.

Hold up a plutonium disk (10 g plutonium at 93% ^{239}Pu). Determine the energy of some of the prominent gamma rays. Identify the isotope producing the activity.

E. NaI Spectra

Hook the NaI (5.08- by 5.08-cm) detector to the scope and MCA. Observe the gamma-ray spectra from ^{137}Cs , ^{235}U , and plutonium. Describe the differences between spectra from the two detectors.

IV. STABILIZED ASSAY METER (SAM) OPERATION AND ENERGY CALIBRATION (2 h for IV)

A. SAM

The SAM is a portable unit containing a hv supply, preamp, amplifier, single-channel analyzer, scaler, and timer. It also contains circuitry to stabilize the gain of the system by measuring the alpha light output from an ^{241}Am -doped NaI seed in the detector. The 5.08- by 5.08-cm NaI which we are using today does not have such a seed, so the stabilizer is turned off.

B. Controls

The instructor will explain the controls of your particular unit. The threshold and window controls of most single-channel analyzers (SCA), including those on the SAM, are 10-turn pots. On the SAM each covers a 1.0-V range. The amplifier saturates at about 3.0 V. Hook a scope to the amplifier output and observe the output pulses. Vary the hv and gain controls (the latter requires removal of the top cover) and note their effect. The instructor will explain the operation of a SCA and will demonstrate a method of triggering the scope off the SCA output to make a crude check of window location.

C. Energy Calibration

1. Let T = threshold setting, W = window setting.
2. Hold a ^{137}Cs source in front of the detector; adjust hv so that the cesium peak is ~ 0.9 V as seen on the scope. This keeps the region of interest (150-700 keV) in the most linear portion of the SCA range. If the SAM is used in the stabilized mode, the internal gain and sensitivity controls are used for this adjustment.
3. Set $T = 1.00$, $W = \text{out}$. Adjust the source position so that the ratemeter reads between 3 and 5×10^5 counts/min.

4. Set $W = 0.20$.

5. Adjust threshold to find peak (roughly) with ratemeter (should be around 9.0).

6. Set the threshold 0.80 below approximate peak location. Take 1/2-min counts every 0.20 from this setting to 0.80 above the approximate peak location. Record these values in the appropriate columns on the linear graph sheets provided. Plot the data points on the graph (plot as 0.2-wide bins). See Fig. 1.2.

Time	W	T	Count	
0.5 m	0.2	7.7	1308	^{137}Cs
		7.9	2195	
		8.1	7303	
		8.3	19825	
		8.5	33518	
		8.7	32411	
		8.9	17722	
		9.1	5151	
		9.3	892	
0.5 m	0.2	1.8	5405	^{238}U
		2.0	8153	
		2.2	8117	
		2.4	23431	
		2.6	14618	
		2.8	2414	
0.1 m	1.0	7.7	6125	^{137}Cs
		7.8	7953	
		7.9	9320	
		8.0	10138	
		8.1	10820	
		8.2	10529	
		8.3	10469	
		8.4	9720	
		8.5	8509	
		8.6	7111	
		8.7	5422	
8.8	3661			
8.9	2296			

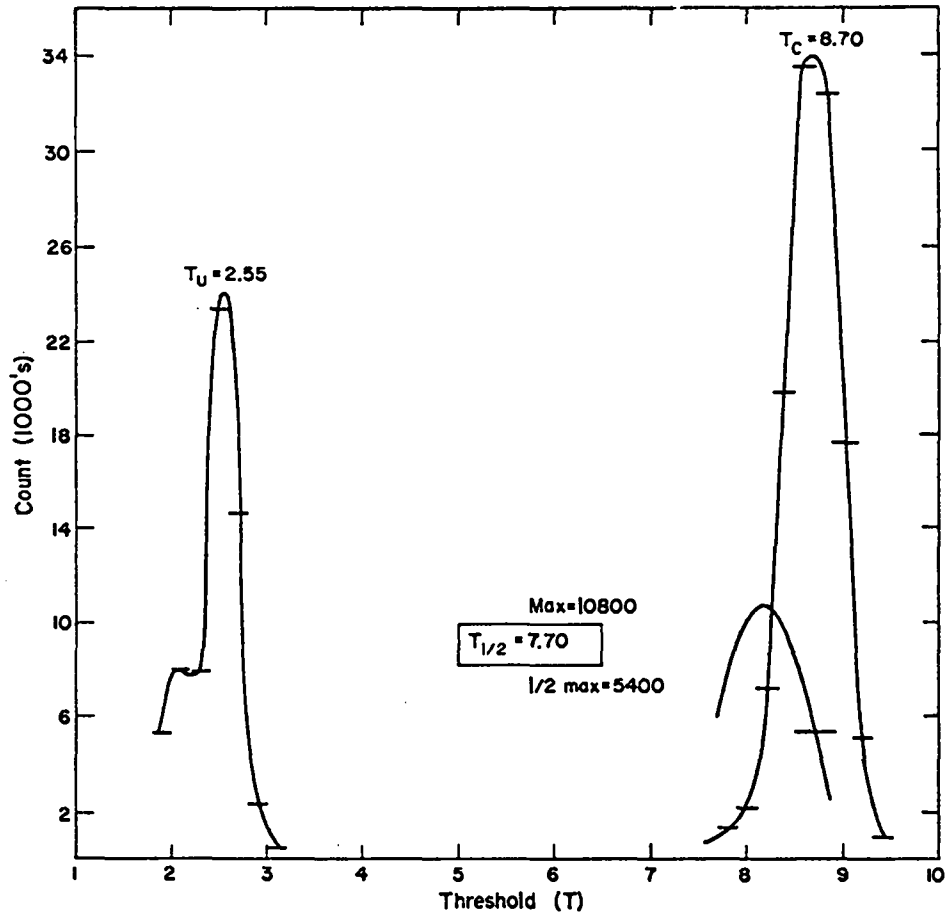

Fig. 1.2. Sample calibration data.

7. Draw a line through the center of the bins and find the peak location. Record this.

$$662 \text{ keV} = \text{_____} (T_c)$$

8. Now remove the cesium source and hold up the small uranium foil (it may have to be positioned closer to the detector to give an adequate count rate). With $W = 0.2$, run the threshold down to locate the 186-keV peak (should be about 2.4).

9. Take 1/2-min counts with the threshold set from 0.60 below approximate location to 0.60 above. Record these and plot as above on same graph. Record the peak location.

$$186 \text{ keV} = \text{_____} (T_u)$$

10. Single-point calibration. Assume energy (E) = 0 corresponds to T = 0 and linear E vs T relation. Then using the cesium point only

$$m = 662/T_c \text{ _____}$$

$$E = mT$$

This is the simplest calibration procedure and requires only one known source. It is usually adequate for our purposes. The SAM electronics is slightly non-linear, so this procedure has some error. As an example of the degree of this error compute

$$E = mT_u = \text{_____}$$

This should be 186 keV; the difference illustrates the error in the assumptions above.

11. Double-point calibration. Assume $E = mT + b$ (i.e., a nonzero intercept). This is a slightly more accurate procedure and should give good results between the two calibration points.

$$m = \frac{662 - 186}{T_c - T_u} = \text{_____}$$

$$b = 186 - mT_u = \text{_____}$$

D. Half-Maximum Calibration Check Procedures

1. The procedure given above is used for the initial setup of the SAM. It is too time-consuming for a routine check for instrument drift. The following procedure is advised for this.

2. First determine the threshold setting which gives half the maximum count rate.

a. Put the ^{137}Cs source back up. Set $W = 1.00$ (this covers most of the peak activity as shown in the first spectrum). In practical situations it may be easier to set W to the assay window width.

b. Find the maximum count location (roughly). Back off about 0.50. Take 0.1-min counts every 0.10 between this threshold setting and about 0.80 above maximum count location. Plot these (as points) on the same graph as before.

c. Determine the maximum count rate and divide this by two.

$$\text{max} = \text{_____}$$

$$1/2 \text{ max} = \text{_____}$$

d. Now, from the plot of count vs T, determine that threshold setting which yields a count rate of 1/2 max. Record this.

$$T_{1/2} = \text{_____}$$

This is the benchmark for later gain checks.

e. Set $T = T_{1/2}$ and check that you do set about 1/2 max.

3. The check procedure is as follows: (the procedure given in 2 above is only performed once to establish $T_{1/2}$).

a. Place the check source in front of the detector (^{137}Cs).

b. Determine the maximum count rate with W set as in 2.

c. Divide the maximum rate by 2 (1/2 max).

d. Set $T = T_{1/2}$ and take a count. If this count is within 10-20% of 1/2 max, the gain is okay. If not, adjust the system gain (hv or amplifier gain) to bring this in line.

4. The advantage of this procedure over just checking for peak location is that the 1/2-max point is more sensitive to changes in gain. Small changes in gain produce relatively small changes in count rate near the peak but produce large changes in count rate near the 1/2-max point. This is illustrated in Fig. 1.3. When doing an actual count, remember to reset the threshold after the 1/2-max check.

5. It is also possible to check the system gain by counting a check source in a fixed and reproducible position. This is the quickest field check of instrument stability. It is not as positive a check as that outlined in 1-4 above.

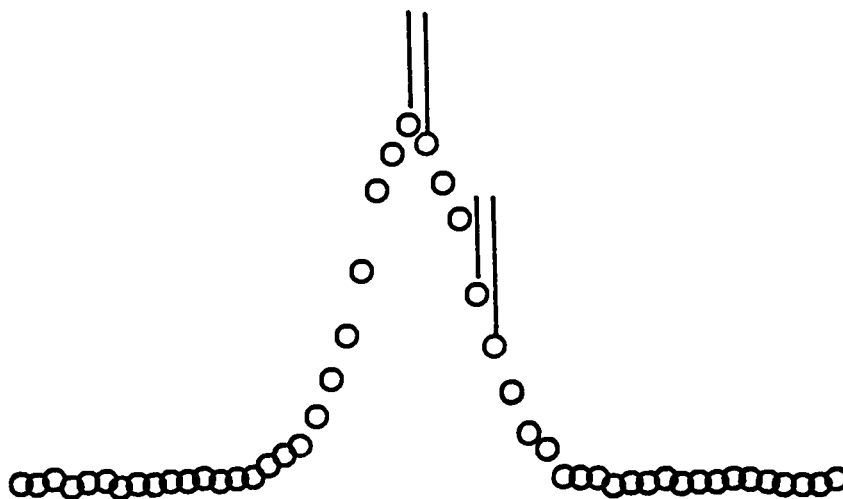

Fig. 1.3. Count rate changes near peak and 1/2-max point. The same gain shift (indicated by the vertical bars) produces a much larger change in count rate near the 1/2-max point.

E. Plutonium Procedure

1. Place the 10-g plutonium disk in front of the detector (about 7.6 cm). Place cadmium and lead sheets in front of source. Notice their effect on the spectrum as seen in the scope. Based on your knowledge of the energy calibration of this system, try to identify the bright bands in the scope. Explain the effect of the different absorbers in terms of the discussion of γ -ray attenuation in Secs. 1.2.a - 1.2.h of the Manual (particularly, Figs. 1.4, 1.6, 1.10). The instructor will help with this.

2. Set $W = 0.20$. Take short counts (0.1 to 0.2 min) every 0.2 from $T = 0.80$ to about $T = 6.0$ or 7.0 (stop when the 400-keV complex is past).

3. Record these data on a different sheet of linear graph paper. Plot count rate vs threshold setting.

4. As seen on the scope there are three or four prominent features in this spectrum. Compute their energy and identify their origin. You may have trouble with the lowest energy line; ask the instructor about x-ray fluorescence.

5. For most plutonium assays a window is set from 375 to 450 keV. This avoids the 333-keV activity of ^{241}Pu daughters. Mark the extent of this window on your graph.

6. The procedure (illustrated here) of measuring a γ -ray spectrum using a SCA is somewhat time-consuming but can be very useful. Whenever results lead you to suspect an interfering γ -ray activity, you should check this out by measuring the spectrum. Remember in normal SCA operation you are "flying blind," i.e., assuming that the spectrum remains constant and the activity in your window is from the isotope of interest. This procedure is the most powerful diagnostic available with the instrument unless you have access to a scope and multichannel analyzer.

F. Uranium Procedure

The gain settings and procedures discussed above apply to plutonium assay. They can be used for uranium assay; however, they put the 186-keV activity at a low pulse height. If only ^{235}U is to be measured, a different gain setting and check source (^{235}U) are used in the instrument calibration. Otherwise the procedure is identical. The third laboratory will pertain to ^{235}U enrichment measurements and will require a recalibration of the SAM unit.

V. COUNTING STATISTICS (2 h for V, VI, VII)

A. Check gain using cesium source and 1/2-max check procedure.

max = _____

1/2 max = _____

set T = $T_{1/2}$

count = _____

Adjust if required.

Note: Remember to readjust the threshold after the 1/2-max check.

B. Set the window on the cesium peak as determined above; W = 1.00. Set the source so that 0.1-min count gives roughly 10^4 counts in peak.

C. Take ten 0.1-min counts; record.

_____	_____	mean = _____
_____	_____	sigma = _____
_____	_____	$\sqrt{\text{mean}}$ = _____
_____	_____	
_____	_____	

Compute the mean and standard deviation of these 10 counts using Eqs. (B-1) and (B-2) from Appendix B of the Manual. A calculator is available for this, as is a programmable calculator with a program for computing the mean and standard deviation (instructor can show you how to use this).

D. Compare the square root of the mean with the standard deviation computed from Eq. (B-2). It should be about equal.

E. Move the source back until only 300-500 counts in peak in 0.1 min. Take 10 counts and compute mean and standard deviation again.

_____	_____	mean = _____
_____	_____	sigma = _____
_____	_____	$\sqrt{\text{mean}}$ = _____
_____	_____	
_____	_____	

F. Set the cesium source near the detector. Adjust the source so that there are about 150 000 counts/min in a window 325 to 450 keV. Now set the plutonium source behind two 0.16-cm lead sheets. Place the source such that the count rate rises 5 000-10 000 counts/min. Take a 0.1-min count in this configuration. Mark the source position and remove the source. Now take a 0.1-min count in this configuration (call this background). Repeat this four more times and record below.

<u>Peak</u>	<u>Back</u>	<u>P - B</u>
_____	_____	_____
_____	_____	_____
_____	_____	_____
_____	_____	_____
_____	_____	_____
_____	_____	_____

mean = _____
sigma = _____
 $\sqrt{\text{mean}}$ = _____
 $\sqrt{\overline{P} + \overline{B}}$ = _____

mean = _____ (\overline{P}) _____ (\overline{B})

Compute the mean and standard deviation as indicated. Be sure you understand the origin of the last expression $\sqrt{\overline{P} + \overline{B}}$. This illustrates a particularly poor counting situation where the background is many times the signal (P - B).

VI. INVERSE SQUARE LAW

A. Tape a cesium source to the lab jack so that it is centered on the detector. Set cesium windows on the SCA (W = 1.00).

B. With no source in front of detector, measure the background for 2 min. Compute count rate per second.

Back = _____ / 2 min = _____ / s

C. Measure the count rate (per second) as a function of source-to-detector distance (R). Measure R from 2.54 cm behind face of crystal. Measure the count rate at positions indicated below. Choose count times to get at least 3000 counts total. Record data below.

<u>R</u>	<u>Count</u>	<u>Time</u>	<u>Count/Time</u>	<u>Count/Time - Back</u>
7.6 cm (3 in.)	_____	_____	_____	_____
15.2 cm (6 in.)	_____	_____	_____	_____
22.9 cm (9 in.)	_____	_____	_____	_____
30.5 cm (12 in.)	_____	_____	_____	_____
38.1 cm (15 in.)	_____	_____	_____	_____
45.7 cm (18 in.)	_____	_____	_____	_____
61.0 cm (24 in.)	_____	_____	_____	_____
76.2 cm (30 in.)	_____	_____	_____	_____

D. Plot (C/T - B) vs R on log-log graph paper (2 by 2 cycle). The points should appear to fall on a straight line. Draw this line and determine its slope (instructor can help with this if you're unfamiliar with log-log paper).

slope = _____

E. If time permits, try to estimate the count rate you would expect at 61 cm using Eq. (2.9) in Manual and known source strength.

VII. GAMMA-RAY ATTENUATION

A. Check system gain.

max = _____

1/2 max = _____

rate at $T = T_{1/2} =$ _____

Note: Remember to readjust the threshold after the check.

B. Set window on cesium peak as before. Measure the background for 2 min, and compute the count rate.

$B =$ _____ / 2 min = _____ / s

C. Set the cesium source (use the 100- μ Ci cesium source) so that the count rate is approximately 20 000 in 0.1 min.

D. There are 16 lead sheets (7.6- by 7.6- by 0.161-cm thick) provided for this experiment. The average thickness of these is about 0.161 cm (you can check this with a micrometer). Measure count rate vs the number of lead plates between the source and the detector. Choose count time so that total count is 3000 or better. Compute count rate per second and subtract background. Record data below.

<u>No. of Plates</u>	<u>Count</u>	<u>Time</u>	<u>C/T</u>	<u>(C/T - B)</u>
1	_____	_____	_____	_____
2	_____	_____	_____	_____
3	_____	_____	_____	_____
4	_____	_____	_____	_____
5	_____	_____	_____	_____
6	_____	_____	_____	_____
7	_____	_____	_____	_____
8	_____	_____	_____	_____
9	_____	_____	_____	_____
10	_____	_____	_____	_____
11	_____	_____	_____	_____
12	_____	_____	_____	_____
13	_____	_____	_____	_____
14	_____	_____	_____	_____
15	_____	_____	_____	_____
16	_____	_____	_____	_____

E. Plot $(C/T - B)$ vs N on semi-log graph paper (2 cycle x 140 div). The points should lie on a straight line. Draw this line and determine its slope; convert N (number of plates) to cm.

$$\text{slope} = \text{_____ cm}^{-1}$$

Look up the tabulated value of μ (μ) for lead at 662 keV. Discuss the agreement with your measured number. _____

F. If time permits, measure the attenuation of the steel and aluminum plates provided. Compute μ for them and compare with the listed values. Measure the attenuation coefficient of these materials at 186 keV using the uranium foil. Repeat some of these measurements with the Ge(Li) detector to see if there is any significant difference between the two measurements.

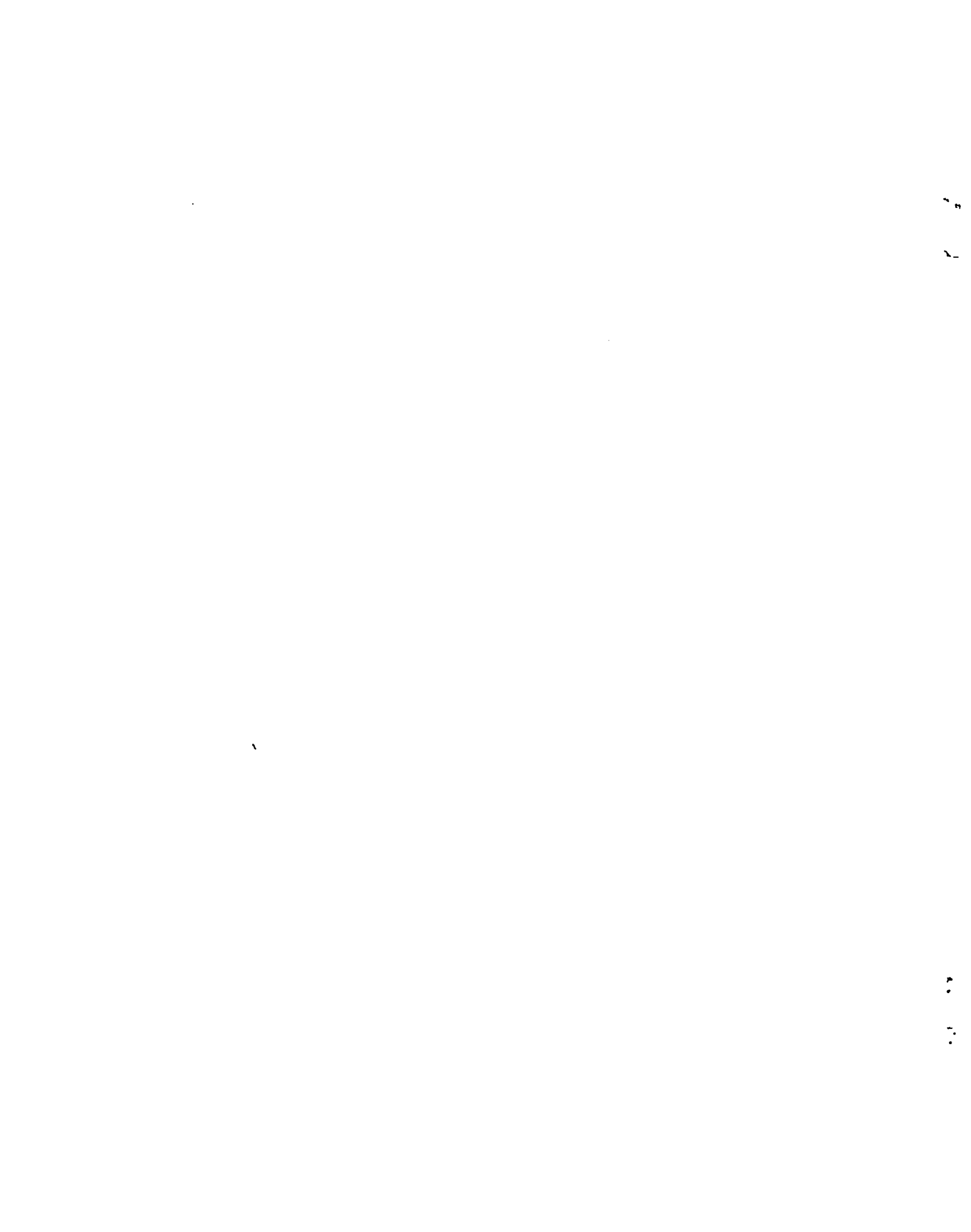

LABORATORY NO. 2

SUGGESTED PROCEDURE FOR PLUTONIUM ASSAY WITH NaI DETECTOR
AND PORTABLE ELECTRONICS

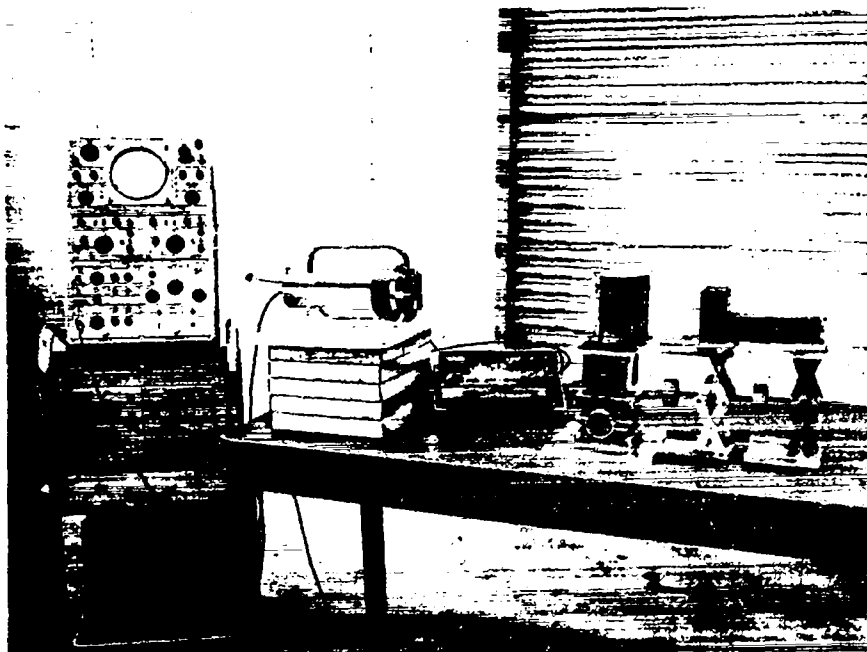

Fig. 2.1. Physical setup of Laboratory 2.

Preliminary Comments: The procedure outlined here is similar to the example described in Sec. 5.5 of the Manual. For the laboratory exercise, however, ^{137}Cs will be used as a transmission source rather than ^{22}Na . More detailed suggestions will be given on how to set the single-channel analyzer (SCA) windows, measure the transmission, etc. The suggestions will be tailored to the use of the Eberline SAM II but may be applied almost directly to any electronics package employing a SCA to count particular spectral regions.

I. ENERGY CALIBRATION

A. The calibration from Laboratory 1 should suffice here.

B. Use the 1/2-max check procedure to verify the gain. Set $W = 1.00$, hold up the cesium source, and determine the maximum count rate.

max = _____

1/2 max = _____

set $T = T_{1/2} =$ _____ as determined in Laboratory 1

count = _____

Adjust gain if required.

Note: Remember to readjust the threshold after the check.

II. COUNT GEOMETRY AND EQUIPMENT ARRANGEMENT

A. For the samples used in this exercise, we suggest a sample detector distance of ~ 46 cm.

B. The transmission source is far enough behind the sample position to allow at least 5.08 cm of lead to be placed between the sample and source, and it is centered on the detector axis.

C. Generally when assaying for plutonium, a layer of cadmium (~ 0.08 cm) and a layer of lead (~ 0.15 cm) across the detector face is most helpful in reducing the otherwise high rates from the intense low-energy gamma rays emitted by plutonium samples.

D. The detector and transmission source are placed high enough to permit scanning the sample through the "transmission gamma-ray beam".

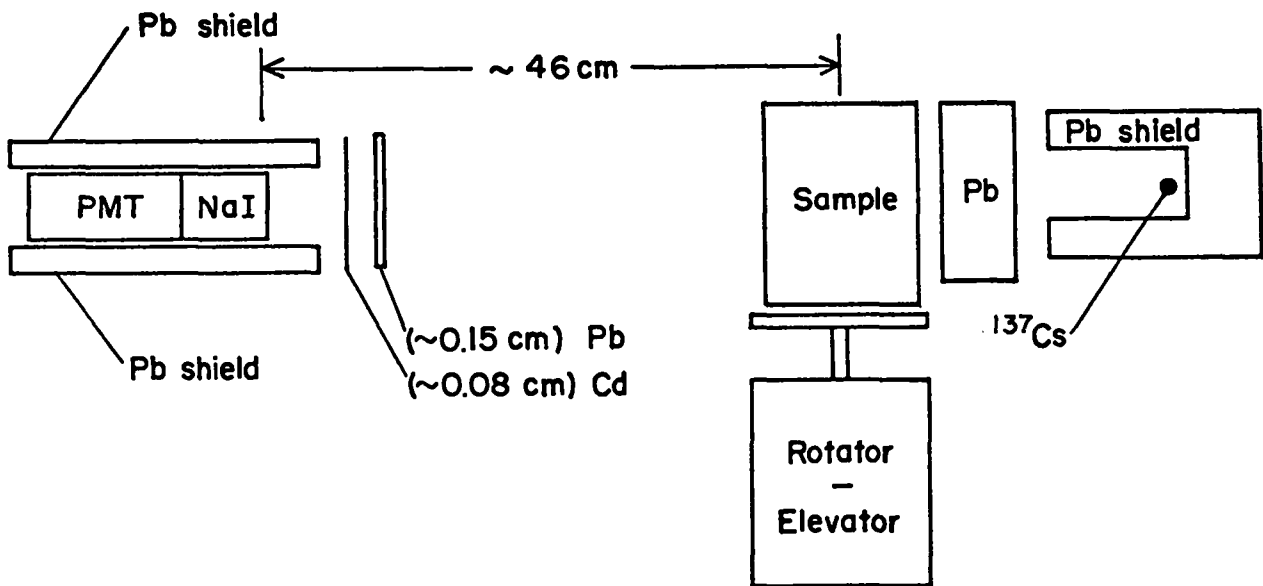

Fig. 2.2. Schematic of plutonium assay equipment.

III. DATA ACQUISITION

A. In the suggested procedure for this lab exercise we will count four regions. Figure 2.3 shows spectra on which the regions are indicated. The corresponding threshold and window settings are computed below.

1. Plutonium region (375 to 450 keV). The lower bound of this region is at 375 keV to avoid counting the ^{241}Pu gamma at 333 keV. We wish to measure

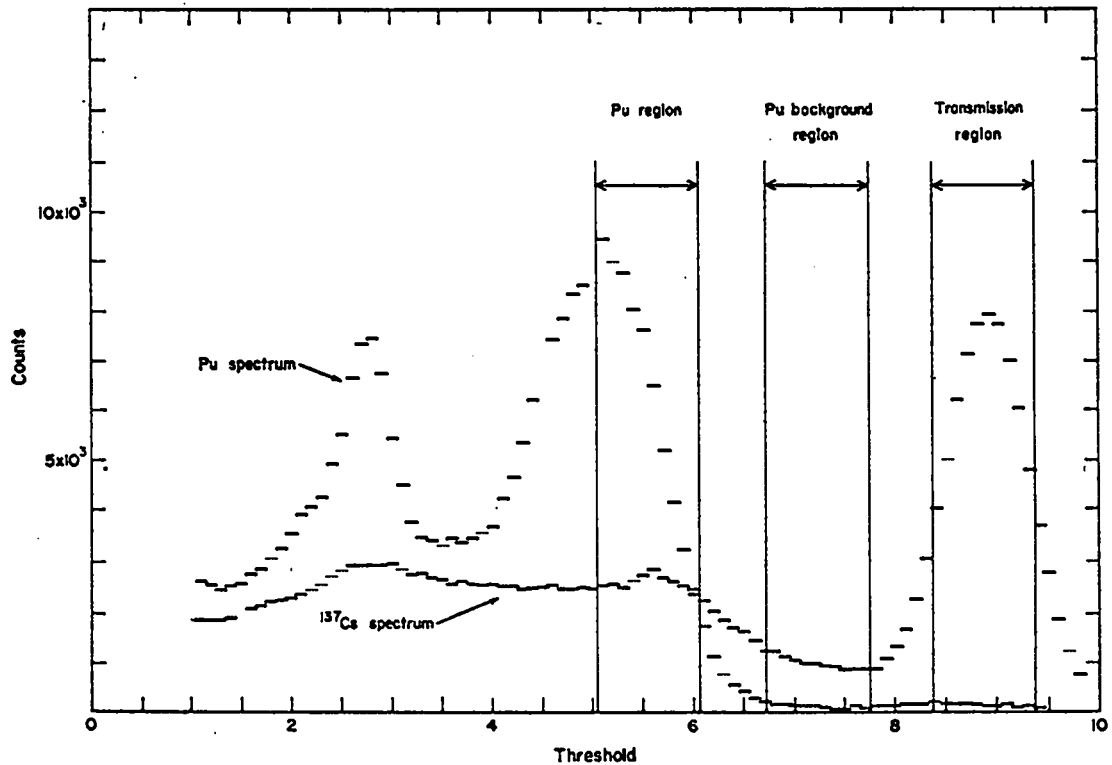

Fig. 2.3. Sample spectra of ^{137}Cs and plutonium, showing regions to be counted for plutonium assay.

^{239}Pu only. The upper bound is at 450 keV, still a little into the plutonium spectrum, but we wish to have a "near maximum" peak-to-background ratio.

2. Plutonium background region (500 to 575 keV). The lower bound is at 500 keV in order to avoid counting any ^{239}Pu activity from the "375-keV complex". We choose the width equal to that of the plutonium region for simplicity.

3. Transmission region (620 to 695 keV). It is convenient to use the same window width as for the plutonium regions.

4. Compute the desired window settings using the single-point calibration from Laboratory 1: $E = mT$, $m =$ _____

$$W = 75 \text{ keV} = \underline{\hspace{2cm}}$$

$$T_P = 375 \text{ keV} = \underline{\hspace{2cm}}$$

$$T_B = 500 \text{ keV} = \underline{\hspace{2cm}}$$

$$T_T = 620 \text{ keV} = \underline{\hspace{2cm}}$$

B. Four counts will be made on each sample: one for the plutonium region, one for the plutonium background region, and two for the transmission region. Table 2.1 illustrates a sample sheet for recording data and computations.

TABLE 2.1
 SAMPLE COMPUTATIONS OF GRAMS PLUTONIUM^a

Sample ID & Mass (g)	C _P	C _B	K=1.4		Lead in Position	$\frac{C_T - C_{TB}}{C_{TO}^b}$	$\frac{\mu(414)}{\mu(661)}$	T _T ^R	$\frac{\pi}{4} \ln \frac{T_A}{T}$	C _{Pu} * CF ^c	$\frac{CC}{Cal}$	Estimated Precision (%)
			C _{Pu}	C _T		C _{TO} ^b	R	T _A	CF		CC	
627B	67568	1464	65518	38069	1495	0.412	1.23	0.336	1.49	97621	78.41	0.5
	67303	1478	65234	37819	1439	0.410	1.23	0.334	1.49	97198	78.07	0.5
292B	31180	1091	29653	54635	1044	0.604	1.23	0.538	1.26	37362	30.01	0.6
	31089	1166	29457	54690	1123	0.604	1.23	0.538	1.26	37116	29.81	0.6
338B	7595	808	6464	54869	461	0.613	1.23	0.548	1.25	8080	6.49	1.4
	7584	843	6404	54337	444	0.607	1.23	0.541	1.26	8069	6.48	1.4

^a Harshaw 5.08- by 5.08-cm NaI, unstabilized; 1-min counts.

^b C_{TO} = 88707.

^c Calibration factor = 1245 corrected counts/g ²³⁹Pu.

1. Plutonium region count. It is suggested that channel 1 on the SAM II be used for this count, which is designated C_p on the data sheet. Transmission source is "shut off" by lead block.

2. Plutonium background region count. It is suggested that channel 2 on SAM II be used for this count, designated C_B on the data sheet. Again, transmission source is "shut off".

3. Transmission background. Channel 2 is suggested. One has to change threshold only. Transmission source is "shut off". Designation on data sheet is C_{TB} .

4. Transmission count. Again use channel 2, with same settings as for 3 but with lead block removed. Designation on data sheet is C_T .

IV. COMPUTATION OF GRAMS PLUTONIUM

A. The computations are outlined in Table 2.1. First, the ^{239}Pu count is obtained from $C_{pU} = C_p - K \cdot C_B$. A problem is determining K , although if $C_p \gg C_B$, one doesn't have to know it to great accuracy. If the regions are of the same width, one may take $K = 1$ with little error. A somewhat better value would be to set K such that $C_p = K \cdot C_B$ for a background count.

B. The fractional transmission of the ^{137}Cs is found from $(C_T - C_{TB})/C_{T0}$. C_{T0} is the straight-through transmission count, i.e., $C_T - C_{TB}$ with no sample.

C. Using a reasonable value for $R = \mu(414)/\mu(662)$, one finds the transmission at 414 keV from $T_A = T_T^R$. In these samples where the plutonium mass is known to be a small fraction of the total, $R = 1.23$ is a reasonable value.

D. Using T_A , one computes the correction factor from

$$CF = \frac{-(\pi/4) \ln T_A}{1 - (T_A)^{\pi/4}}, \quad (2.1)$$

where

$$\pi/4 = 0.785.$$

E. The corrected plutonium count is given simply by $CC = C_{pU} \cdot CF$.

F. Finally, the quantity of ^{239}Pu is computed by dividing the corrected counts by the calibration factor which is determined by counting a standard containing a known quantity of ^{239}Pu . The calibration factor is expressed as "corrected counts per gram".

G. Some estimate of the uncertainty of a given measurement should be made. A suggested procedure for this exercise is given in the next section.

V. ESTIMATE OF PRECISION

A. In Sec. 5.5 of the Manual an approximate formula is given for the uncertainty in the measured mass. Expressed in the notation of this laboratory exercise, it is:

$$\frac{\sigma(M)}{M} \approx \sqrt{\underbrace{\frac{C_P + C_B}{(C_P - C_B)^2} + (0.25) \left[\frac{C_T + C_{TB}}{(C_T - C_{TB})^2} \right]}_{\text{Precision or Repeatability}} + \underbrace{\left[\frac{\sigma(\text{Cal})}{\text{Cal}} \right]^2}_{\text{Uncertainty in Calibration Factor}}} \quad (2.2)$$

B. The first two terms estimate the uncertainty due to random variations in rate and govern the precision or repeatability of the measurement. The third term estimates error due to uncertainty in the calibration factor (which is determined by measurements on a standard). Error in calibration affects all measurements by the same factor and therefore represents a bias on all measurements. It is therefore worth considerable effort to reduce the error in the calibration factor.

C. Because of other effects (sample shape, sample heterogeneity, unknown matrices, instrument drift, etc.) the actual one-sigma (1σ) accuracy of measurements with portable NaI instrumentation is rarely better than 5%, even when the precision is much better. Table 2.2 shows the estimate of precision for the three cases of Table 2.1. This is a reasonably typical case. The precision is very good ($\sim 1\%$), the uncertainty of calibration is $\sim 4\%$ (due to lack of a well known standard), and general 1σ accuracy is probably $\sim 5\%$.

VI. PROCEDURE FOR LABORATORY EXERCISE

- A. Set up equipment as outlined in II above, using 5.08- by 5.08-cm NaI probe--unstabilized.
- B. Check the energy calibration.
- C. Using the sample designated as the "standard," determine the calibration constant. Measure the standard perhaps five times to get a good value, and compute the precision of the value. Use forms shown in Table 2.1.
- D. Assay the unknowns, again using the forms provided for data entry and computation.
- E. Compute precision for the assays--see example of Table 2.2.
- F. Compare results with values previously obtained by calorimetry and with results of others doing the exercise.

TABLE 2.2
ESTIMATE OF PRECISION FOR
THREE CASES SHOWN IN TABLE 2.1

$$\frac{\sigma(M)}{M} \approx \sqrt{\frac{C_P+C_B}{(C_P-C_B)^2} + (0.25) \left[\frac{C_T+C_{TB}}{(C_T-C_{TB})^2} \right] + \left[\frac{\sigma(\text{Cal})}{\text{Cal}} \right]^2} \quad \text{Fractional Standard Deviation}$$

Sample ID	C_P	C_B	C_T	C_{TB}	$\frac{C_P+C_B}{(C_P-C_B)^2}$	$\frac{1}{4} \left[\frac{C_T+C_{TB}}{(C_T-C_{TB})^2} \right]$	$\left[\frac{\sigma(\text{Cal})}{\text{Cal}} \right]^2$	$\frac{\sigma(M)}{M}$	M (g Pu)	$\sigma(M)$ (g)
627B	67568	1464	38069	1495	1.58×10^{-5}	7.39×10^{-6}	0.00	0.005	78.41	0.4
	67303	1478	37819	1439	-----very nearly the same as above-----					
292B	31180	1091	54635	1044	3.56×10^{-5}	4.84×10^{-6}	0.00	0.006	30.01	0.2
	31089	1166	54690	1123	-----very nearly the same as above-----					
338B	7597	808	54869	461	1.82×10^{-4}	4.67×10^{-6}	0.00	0.014	6.49	0.9
	7684	843	54337	444	-----very nearly the same as above-----					

Note: In this example, $\sigma(\text{Cal})/\text{Cal}$ has been set to zero to show only the random statistical variations. Note that the duplicate measurements agree within the estimated precision. In fact, for this case, $\sigma(\text{Cal})/\text{Cal} \sim 0.04$ would clearly dominate the expression for $\sigma(M)/M$. Although the precision (repeatability) is good in this example, experience indicates that error in the calibration factor and systematic errors and inhomogeneities in the sample would limit actual accuracy to no better than 5% at the 1 σ level.

LABORATORY NO. 3

URANIUM ENRICHMENT MEASUREMENTS

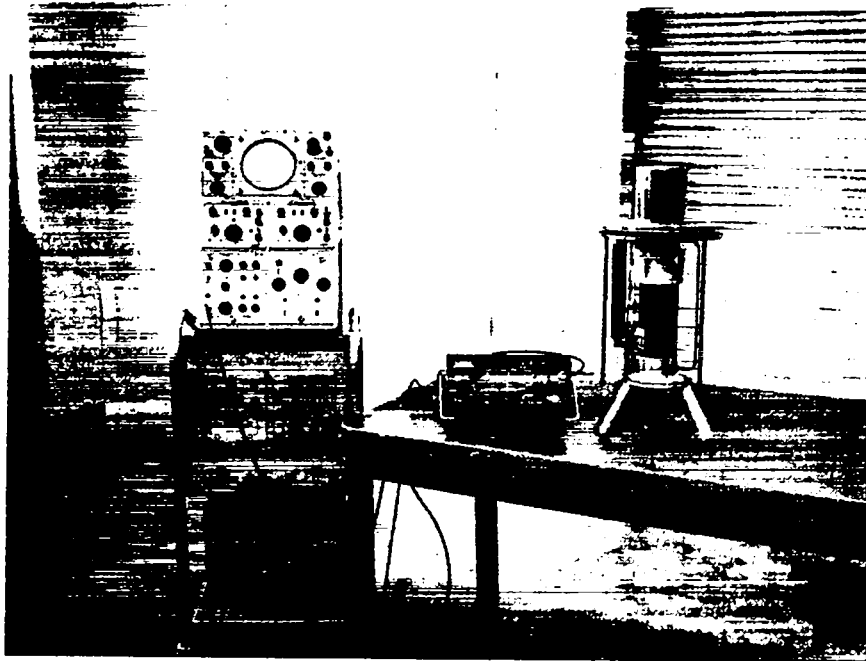

Fig. 3.1. Physical setup of Laboratory 3.

I. SAM II (NaI) SETUP FOR ENRICHMENT DETERMINATION

A. Prerequisite

Read carefully the material in Chapter 6 of the Manual. Pay particular attention to sections 6.7 and 6.8, which are examples of measurement and calibration procedure for UF_6 enrichment measurements.

B. NaI Spectra of Uranium Gamma Rays

Figure 3.2 shows a pulse-height distribution of gamma rays from a 93% enriched uranium metal foil. Essential features are the peaks due to the 186- and 143-keV gamma rays from ^{235}U and the uranium K x rays. The change in the gamma spectrum with enrichment is illustrated by the pulse-height distributions of gammas from cans of uranium oxides shown in Fig. 3.3. Take MCA pulse-height distributions on two different enrichments of uranium oxide, using the SAM II provided. Note that the Compton background from high-energy gamma rays for materials with enrichment $\leq 10\%$ is relatively large; therefore, if not subtracted properly, this background can produce large errors in enrichment measurements with NaI.

C. SAM II Setup Procedures

1. Physical arrangement and gain setting. Set the collimator depth of each probe to 7.62 cm (3 in.), measured from the front surface of the collimator

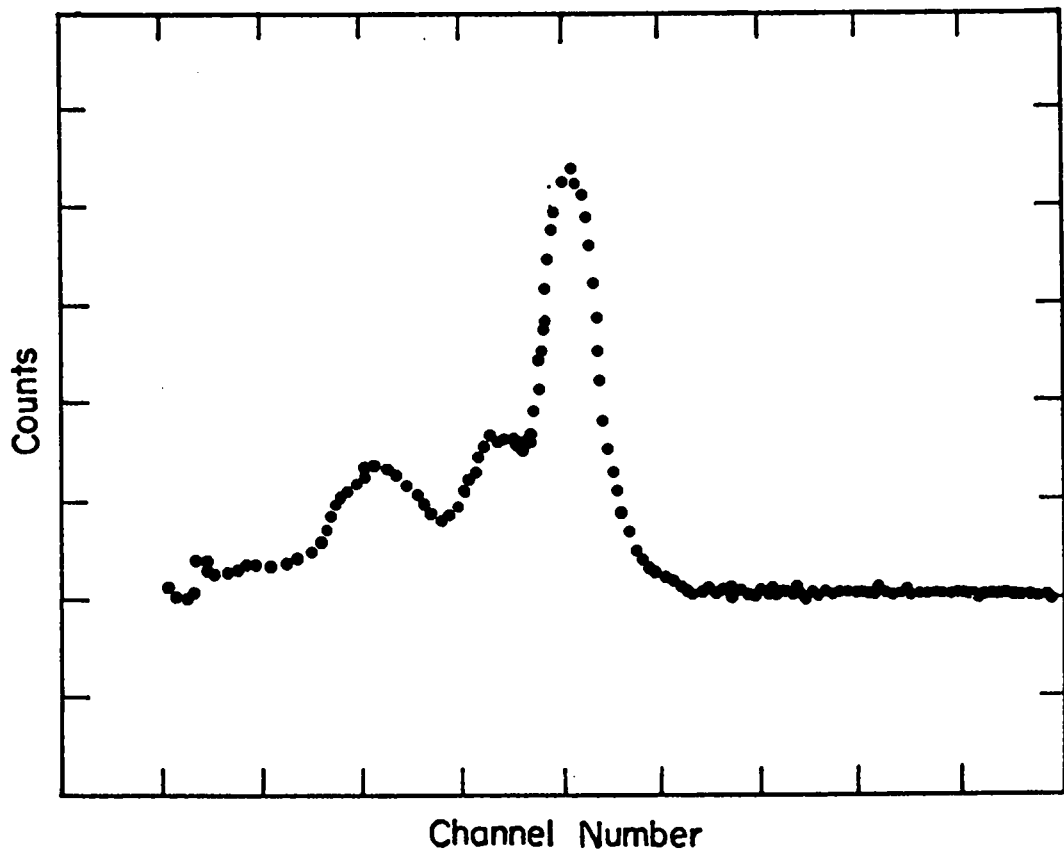

Fig. 3.2. Pulse-height distribution of 93% enriched uranium metal foil.

to the surface of the NaI probe. This collimator depth permits measurements of enrichments up to 97% without significant electronic counting losses. If the range of enrichments is $< 10\%$, smaller collimator depths may be used to reduce measurement time. Note: 0.08-cm cadmium disk glued to the front surface of the probe is essential. It preferentially attenuates x rays from uranium as well as secondaries produced in the collimator.

Adjust the gain of each SAM II such that the 186-keV gammas from the standard foil, placed diagonally into the collimator, produce 0.5-V pulses, as estimated using an oscilloscope display of the amplifier-out pulses. Use gain control R8, Fig. 2.2 of Eberline SAM II technical manual. The oscilloscope display should look like Fig. 3.4.

2. Energy calibration. Use the single-point calibration method described in Laboratory 1 (IV.C) substituting the ^{235}U standard for the ^{137}Cs source. Place the ^{235}U standard in the collimator; set $W_A = 0.1$ (dial setting). Find the threshold setting T_A (with ratemeter) at which the first count-rate maximum occurs as T_A is lowered from its maximum setting of 10.0. For convenience of notation, channels 1 and 2 of the SAM II are referred to as "A" and "B". Now lower T_A to about 90% of the peak setting, and take 0.5-min counts at intervals

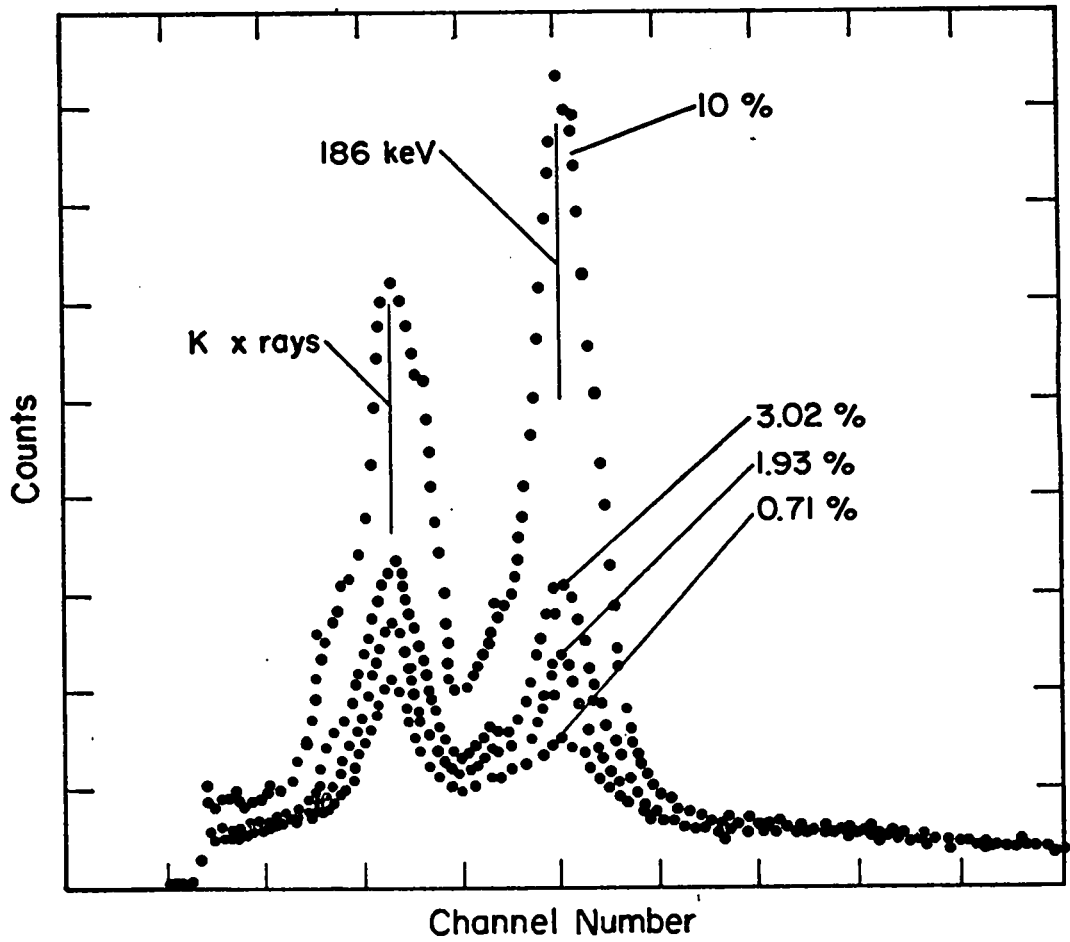

Fig. 3.3. Pulse-height distributions of four different enrichments of uranium oxide.

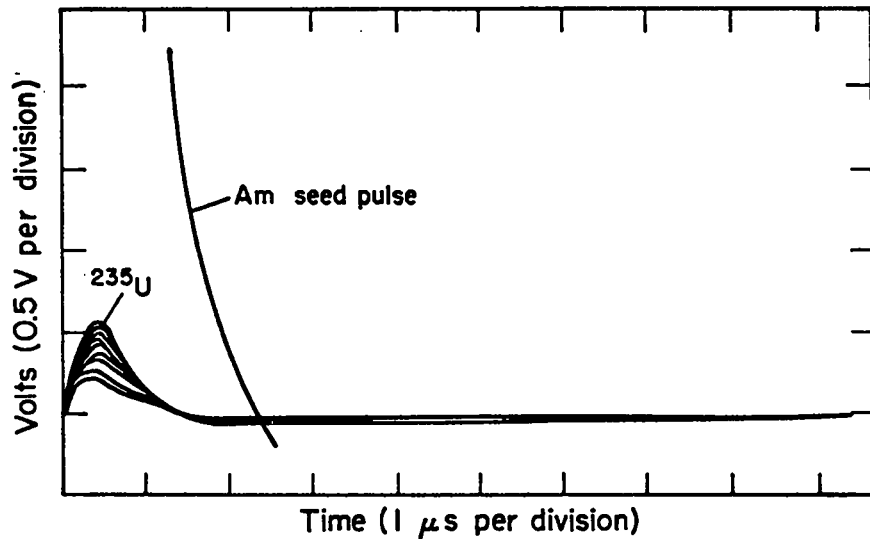

Fig. 3.4. Oscilloscope display of ²³⁵U gamma-ray pulse from a SAM II.

of 0.1 as T_A is moved over the peak to about 1.1 times the peak setting. Record these values and plot the data points on a linear graph (plot as 0.1-wide bands).

Find the peak location T_U on the plot, and then solve for the single-point calibration constant m as follows:

$$E = mT_U \quad ; \quad m = \frac{186 \text{ keV}}{T_U} \quad . \quad (3.1)$$

Record:

$$T_U = \underline{\hspace{2cm}}$$

$$m = \underline{\hspace{2cm}}$$

Using only the ratemeter, the position of the peak observed with the second channel should be checked. If it differs by more than a few percent from that of channel 1, a separate calibration constant should be obtained.

Calculate W_A corresponding to a 50-keV window as follows:

$$W_A = \frac{50 \text{ keV}}{m} \quad . \quad (3.2)$$

Set $W_B \approx 1.4 \times W_A$. Calculate T_A , T_B corresponding to 161 keV and 236 keV, respt.

$$W_A = \underline{\hspace{2cm}} \quad W_B = \underline{\hspace{2cm}}$$

$$T_A = \underline{\hspace{2cm}} \quad T_B = \underline{\hspace{2cm}}$$

These settings are approximately correct for enrichment measurements.

3. The half-maximum count method for setting gain. This method has been described in Laboratory 1. Use the wide window setting for W_A as obtained above (this will be ~ 1.15), and then vary T_A to locate the maximum count. Reduce T_A by about 0.6 from its position of maximum count and then take 0.5-min counts, increasing T_A by increments of 0.2 until the position of the half-maximum count is passed. Record the half-max threshold T_A (1/2 max) below; this is the benchmark for checking the instrument gain. See writeup in Laboratory 1 (IV.D.3) for the check procedure. The only difference is use of a ^{235}U standard instead of ^{137}Cs .

$$T_A (1/2 \text{ max}) = \underline{\hspace{2cm}}$$

It is important that the T_A (1/2 max) be established immediately after the energy calibration in order that the settings T_A , T_B , W_A , W_B for enrichment measurements will be valid.

4. A quick check for gain shifts. A go/no-go method for checking for gain shifts consists of counting the ^{235}U in a fixed, reproducible position. With $E_A = 161 \text{ keV}$, $W_A = 50 \text{ keV}$, a 1-min count is $\sim 28 \text{ 000}$ with the ^{235}U standard provided. A variation greater than ± 500 from the count established at the time of calibration of the unit indicates a serious gain shift; the half-max count method should then be employed to adjust the gain.

Take the average of three 1-min counts to establish the standard count. As this count depends on the collimator depth, it should be recorded.

$$a = \frac{(10.06)(53\,473) - (0.712)(51\,970)}{1.403 \times 10^{10}} = \frac{537\,938 - 37\,003}{1.403 \times 10^{10}} = 3.57 \times 10^{-5},$$

$$b = \frac{(10.06)(73\,358) - (0.712)(333\,675)}{1.403 \times 10^{10}} = \frac{737\,981 - 237\,577}{1.403 \times 10^{10}} = 3.57 \times 10^{-5}.$$

Calculations:

Answers:

a = _____

b = _____

B. Optional Exercises

Exercise A:

If $b/a \neq 1$, the window W_B (or W_2 , referring to channel 2 of SAM II) can be adjusted so that $b = a$, and then $I = aR$. If time permits, try this. Change the window W_B from its initial value $W_B^{(o)}$ by $\Delta W_B = \frac{b-a}{a} * W_B^{(o)}$. Repeat the calibration with 10.0% and 0.712%, solving again for a, b . At this point a, b should be identical to within a few percent. If not the case but if reliable constants a, b were obtained, proceed to Exercise B. If the condition $a = b$ was achieved, then flip in the up-down scaling feature of the SAM II, i.e., C_A^{++} and C_B^{+-} , and take a 5-min count of one of the calibration cans to obtain the net count R . Use the equation $I = aR$.

Answer: _____

Exercise B:

Set up for Direct Enrichment Reading with Digital Rate Multiplier. Dial into the DRM the three most significant figures of a, b ; then flip this unit on and measure one of the standards. This should yield a direct enrichment reading except for placement of the decimal.

Answer: _____

$$\text{Error relative to tag} = \frac{I_{\text{measured}} - I_{\text{tag}}}{I_{\text{tag}}} * 100 = \underline{\hspace{2cm}}\%$$

C. Enrichment Measurements of Cans of Uranium Oxide

Measure the enrichments of the 2% and 3% cans. Take 2-min counts, record the data below, and calculate the enrichment. Calculate the statistical uncertainty using the equation

$$\sigma_{\text{relative}} = 100 \frac{\sigma(I)}{I} = 100 \frac{a^2 C_A + b^2 C_B}{aC_A - bC_B} (\%) \quad (3.5)$$

What are the appropriate constant a, b for a 2-min count based on those obtained for the calibration using the 5-min counting intervals?

<u>Δt</u>	<u>a</u>	<u>b</u>
5 min		
2 min		

<u>Sample No. & Enrichment</u>	<u>Δt</u>	<u>C_A</u>	<u>C_B</u>	<u>I_{measured}</u>	<u>σ_{relative}</u>	Error relative to tag =
						$\frac{I_m - I_{\text{tag}}}{I_{\text{tag}}} * 100$

C. Use of Up-Down Scaling and Digital Rate Multiplier (optional)

Repeat the measurements of II.B for these two different modes of operation of SAM II. Note: each measurement requires only 2 min, but without a knowledge of C_A, C_B separately, one cannot arrive at a statistical uncertainty.

<u>Sample and Tag Enrichment</u>	<u>Δt</u>	<u>I_{measured}</u>	$\frac{I_m - I_{\text{tag}}}{I_{\text{tag}}} * 100$
----------------------------------	------------------------------	---	---

D. Simulation of Enrichment Measurement of UF_6 in Type 30-B Cylinders with Steel Plates and Cans of Uranium Oxide

Check for gain shift by taking a standard count.

Standard count = _____ \pm _____ counts/min

Verify the thickness of a 1.27 cm-thick steel plate with an ultrasonic thickness gauge.

Calibrate for enrichment measurement with 0.63 cm or 1.27 cm steel plates interposed between the standard cans and the detector. [Use 0.712% and 10%

(or 3%) cans for standards.] This plane geometry configuration is a good simulation of the measurement geometry of a 76-cm-diam UF₆ cylinder. Counting times should be 5 min.

a = _____ b = _____

Exercise:

Assuming $\alpha(\text{Fe}) = 0.95 \text{ cm}^{-1}$, are a/a_0 , b/b_0 equal to $e^{-\alpha x}$ where a_0 , b_0 are the calibration constants derived with no absorber?

With the above calibration constants, measure the enrichment of the 2 and 3% cans of oxide. Use a counting time of 5 min.

<u>Sample</u>	<u>Δt</u>	<u>C_A</u>	<u>C_B</u>	<u>I_{measured}</u>
---------------	------------------------------	-------------------------	-------------------------	---

E. Enrichment Measurements of 5-A Cylinders

Three UF₆ cylinders are available. Use one of them as a standard; then measure the enrichment of the others relative to the one "known". Use the ultrasonic thickness gauge to measure the cylinder wall thickness.[†] The equation for enrichment is:

$$I = aRe^{+1.17x}, \text{ or alternatively: } (aC_A - bC_B)e^{1.17x},$$

where the Monel wall thickness is in cm. Let I_0 , R_0 , x_0 = enrichment, count, and thickness of standard, respectively. Then the enrichment of the unknown I with count R and thickness x is:

$$I = I_0 (R/R_0) e^{1.17(x-x_0)}$$

[†] Note: If the thickness gauge is calibrated for steel, divide the reading for Monel by 1.11 to get the true thickness.

Use a count time of 2 min:

$$\frac{\text{Cylinder}}{\frac{I_{\text{tag}}}{R} \cdot X \cdot I_m} = \frac{I_m}{I_{\text{tag}}}$$

LABORATORY NO. 4A

MEASUREMENT OF EQUIPMENT HOLDUP



Fig. 4A.1. Physical setup of Laboratory 4.

I. INTRODUCTION

This laboratory session will be a field assay of highly enriched ($\sim 93\%$ ^{235}U) uranium holdup in sections of the air-duct collection network of a uranium fabrication shop. The first half of the lab session will be devoted to the setup, collimator adjustment, and calibration of a cart-mounted NaI detector. The second half will be devoted to actual measurements of the linear concentration of ^{235}U holdup in a large diameter, low velocity air duct which is used to carry machining residues from lathes, milling machines, and grinders to duct collectors outside the shop. The diameter of the duct varies from 15 to 41 cm over a length of ~ 39 m. The concentration of ^{235}U holdup ranges from 0 to ~ 9 g/m. The most recent assay of this duct was performed on 7/20/73. A graph of the linear concentration of ^{235}U in the duct at that time is given in Fig. 4A.2.

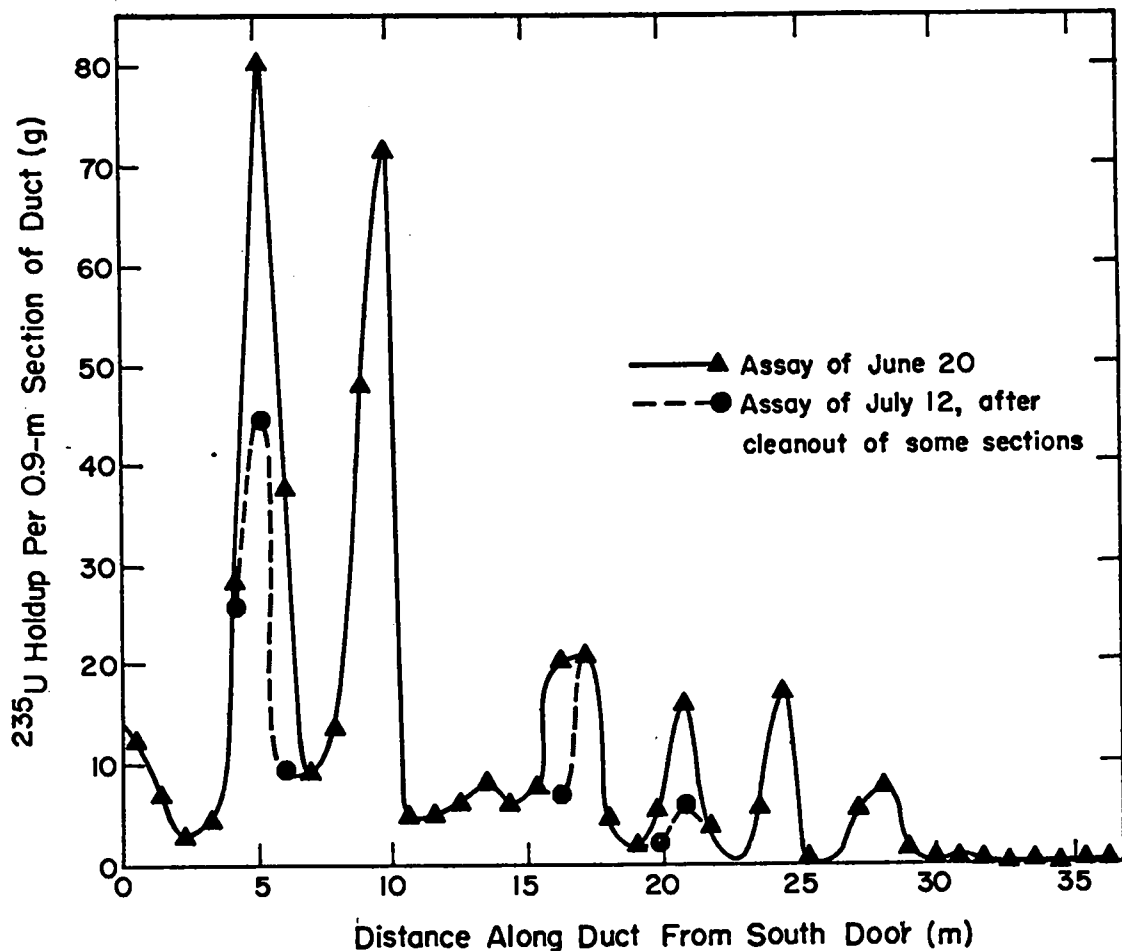

Fig. 4A.2. Uranium-235 holdup concentration in the low-velocity duct on the south wall of Shop 13, Bldg. SM-102.

II. EQUIPMENT

- A. Eberline SAM I or II with 5.08- by 1.27-cm NaI probe
- B. Adjustable lead shield and collimator for NaI probe
- C. Cart for SAM unit and battery, with adjustable tripod on which lead collimator is mounted
- D. Uranium-235 calibration source
- E. Tape rule, two T-squares, tape
- F. Hand calculator

III. PRELIMINARY DISCUSSION

Assume it is desired to measure the ^{235}U holdup in the duct at 91-cm intervals. Assume further that because of certain physical obstructions (machines, etc.) that a practical distance of approach from the detector to the duct centerline is about 1.5 m (see Fig. 4A.3). Under these constraints the collimator setup entails adjusting the collimator depth d (see Fig. 4A.4) such that

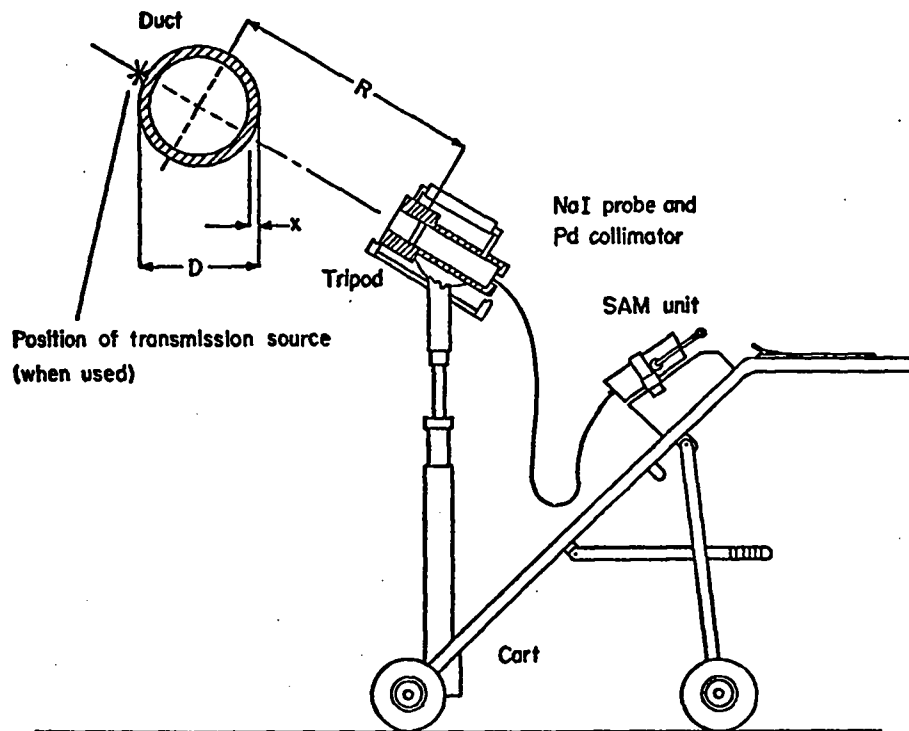

Fig. 4A.3. Equipment setup for the measurement of uranium holdup in a duct.

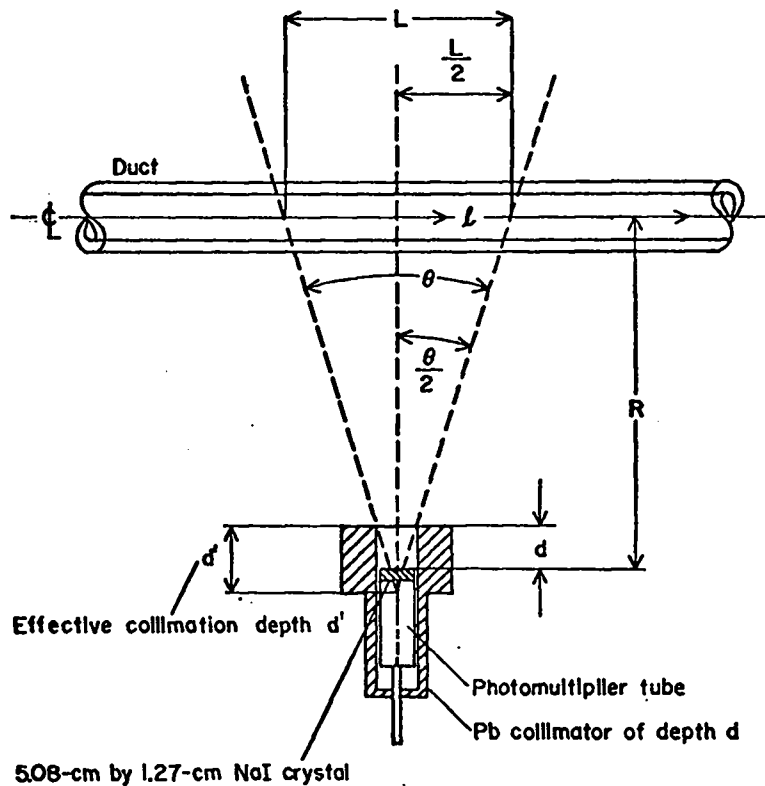

Fig. 4A.4. Duct viewed by a collimated NaI detector.

at $R \approx 1.5$ m the lateral detection efficiency $\epsilon(R, l)$ for detecting material at a distance l on either side of the detector centerline is relatively high up to a lateral distance $l = L/2$ (46 cm in this application). For $l > L/2$, however, $\epsilon(R, l)$ should drop to zero as quickly as possible. Shown in Fig. 4A.5 is a graph of the relative detection efficiency versus lateral distance l from the detector centerline for $R = 1.5$ m and a collimator depth of 6 cm. The graph is typical of the response one obtains with a blunt-ended, cylindrical-type collimator such as will be used in the lab exercise.

The spatial resolution of a collimated detector can be quantified in terms of the FWHM of the curve of efficiency vs lateral distance. This is analogous to the description of the energy resolution of a gamma-ray detector. Let a collimator's field of view L at a distance R from the detector be defined as a chord whose magnitude is equal to the area under the relative lateral efficiency curve:

$$L(R) \equiv \frac{1}{\epsilon_0(R)} \int_{-\infty}^{\infty} \epsilon(R, l) dl \quad , \quad (4A.1)$$

where $\epsilon_0(R)$ is the absolute detection efficiency along the centerline of the detector ($l = 0$). Equation (4A.1) can be approximated by numerical integration of a plot of $\epsilon(R, l)/\epsilon_0(R)$ versus l , as shown in Fig. 4A.5. A quick graphical

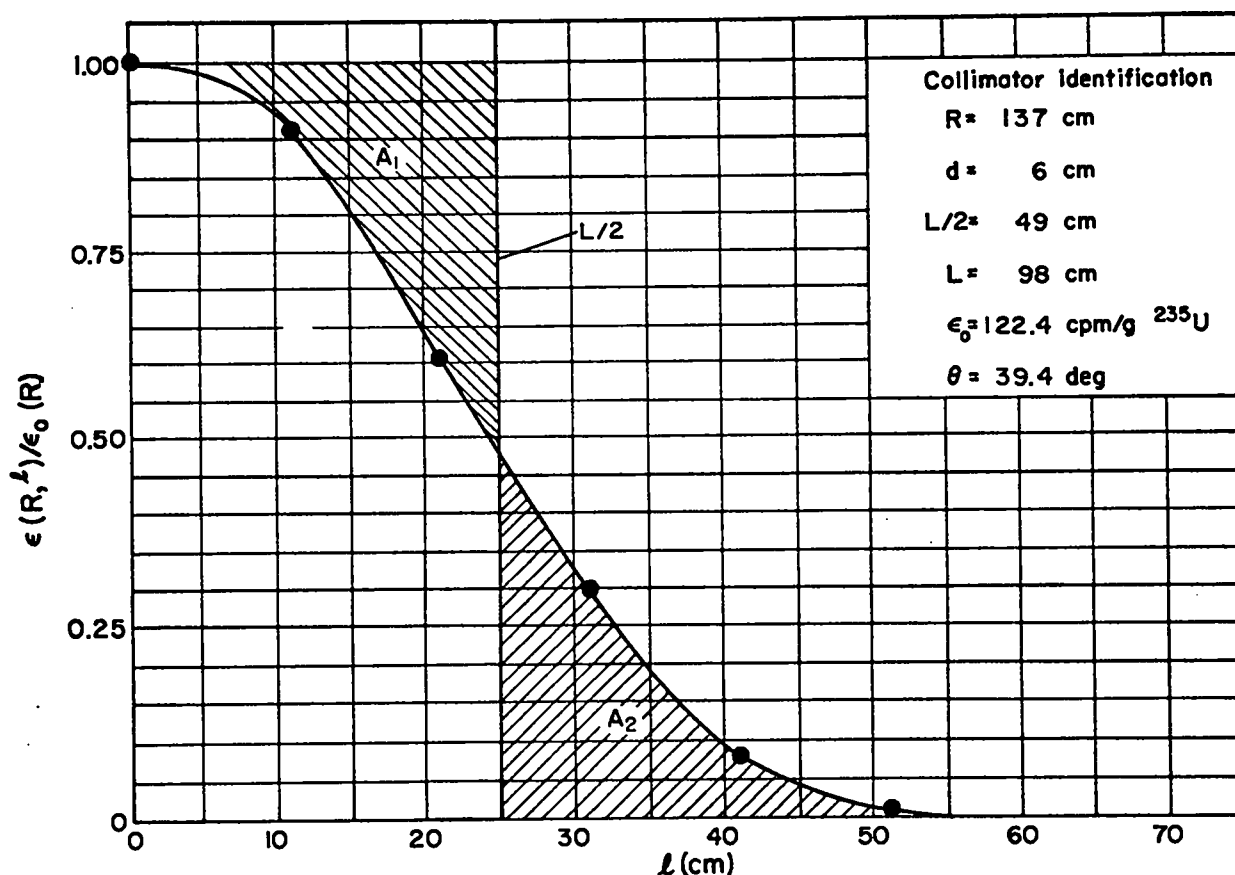

Fig. 4A.5. Relative detection efficiency vs lateral distance from detector centerline.

integration method for determining $L(R)$ in Eq. (4A.1) is to move a thin vertically held straight edge across the graph (Fig. 4A.5) until area A_1 equals A_2 . The point where the line intercepts the abscissa is then $L/2$. When $L/2$ is so defined, the total lateral efficiency is then equivalent to assuming

$$\begin{aligned} \epsilon(R, \ell) &= \epsilon_o(R) & -L/2 \leq \ell \leq L/2 \\ &= 0 & |\ell| > L/2 \end{aligned} \quad (4A.2)$$

This equivalency relationship simplifies the calibration procedure, since $\epsilon_o(R)$ can be determined by a single measurement of the detector's response to a point source of known intensity placed a distance R from the detector, along its centerline. Note also in Fig. 4A.5 that the relative lateral efficiency drops to $1/2$ max at a distance from the centerline of roughly $L/2$. This is generally true and is a good rule of thumb to remember when adjusting the collimation depth for a desired value of L at some distance R .

Because the collimator's field of view can be defined as $L(R)$, from Fig. 4A.3 we can also define the collimator's angular resolution, $\theta(R)$, as

$$\theta(R) = 2 \tan^{-1} \left(\frac{L(R)}{2R} \right) \text{ for } R \gg d \quad (4A.3)$$

It follows from Eq. (4A.3) and Fig. 4A.4 that $L(R)$ is directly proportional to R for a fixed d . Thus, in terms of $L(R_1)$ experimentally determined at a given lateral distance R_1 , a generalized expression for $L(R)$ is

$$L(R) = \frac{R}{R_1} L(R_1) \quad (4A.4)$$

For the collimator whose lateral efficiency is plotted in Fig. 4A.5, at a collimation depth of 6 cm and at $R = 137$ cm, the lateral definition L was found to be 98 cm. If desired, L could be reduced to 91 cm without necessitating a change in collimation depth, simply by reducing R to $(137)(91)/98 = 127$ cm. It must be remembered though that changing R also changes the detection efficiency by inverse square law, i.e.,

$$\epsilon_o(R) = \left(\frac{R_1}{R} \right)^2 \epsilon_o(R_1) \quad (4A.5)$$

where $\epsilon_o(R_1)$ is the absolute efficiency measured at R_1 . The relations given by Eqs. (4A.4) and (4A.5) are extremely useful in situations where it is necessary to make slight to moderate changes in R or L , as the need for recalibrating or remeasuring the lateral definition is eliminated. However, if it becomes necessary to change the collimator depth, both the lateral definition and the efficiency must be remeasured.

Using the relationships given above and a detection configuration similar to the one illustrated in Fig. 4A.4, the linear concentration G of material holdup in a duct can now be expressed in terms of $\epsilon_o(R)$ and $L(R)$ as follows:

$$G(R) = \frac{N}{\epsilon_o(R) L(R)} * CF' \quad (4A.6)$$

where N is the net count rate and CF' is the correction factor for both gamma-ray self-absorption within the holdup material itself and attenuation through the walls of the duct. Note that if ϵ_0 and L were initially measured at R , but that it is subsequently desired to measure G at a distance other than R such as R_1 , one needs only to use Eqs. (4A.4) and (4A.5) for ϵ_0 and L in Eq. (4A.6) to obtain the following new generalized equation for G :

$$G(R_1) = \frac{N * CF'}{\epsilon_0(R) L(R)} \left(\frac{R_1}{R} \right) \quad (4A.7)$$

The correction factor CF' can most readily be determined by the use of the transmission source technique. When the transmission T' is measured, the source should be placed on the surface of the duct diametrically opposite the point on the duct at which the detector is aimed. For reasonable amounts of material in the duct, an excellent approximation for the correction factor CF' is found by assuming the duct plus the holdup material is a flat slab and measuring the transmission T' through the duct. One then calculates CF' as

$$CF' = 1/\sqrt{T'} \quad (4A.8)$$

Also, for very small amounts of material in the duct, CF' can be considered to be equal to the inverse of the transmission through only the steel duct, or

$$CF' = \frac{1}{e^{-\mu_s x}} = e^{+\mu_s x} \quad (4A.9)$$

where μ_s is the linear attenuation coefficient of the steel duct walls, and x is the wall thickness. In general, however, the transmission correction factor CF' should be determined for each section of duct, as expressed in Eq. (4A.8).

IV. PROCEDURE FOR SETUP, COLLIMATOR ADJUSTMENT, AND CALIBRATION

- A. Set up the SAM unit for single-channel analysis of the 186-keV peak from ^{235}U as outlined in Laboratory 3. A 0.08-cm foil of cadmium should be taped to the face of the NaI probe to cut out low-energy x rays and gamma rays.
- B. Find an area in the vicinity of the uranium fabrication shop where the gamma background is relatively low and where it will most likely remain constant over the next hour, e.g., in the parking lot outside. Observing the count rate meter on the SAM, directionally scan the area to acquaint oneself with the whereabouts of any hot spots.
- C. It is desired to set the collimator depth so as to obtain a lateral definition of $L = 91$ cm at $R = 137$ cm (refer to Fig. 4A.4). Based upon the rule of thumb that the lateral efficiency drops to $1/2$ max at a lateral distance of $l = L/2$, the following procedure can be used to arrive at a collimator depth which will yield the desired results.

Position the movable shield on the collimator such that it is flush with the front. Position the face of the NaI probe at a depth d of 5.08 cm from the front of the collimator. Next tape the ^{235}U calibration source to a wall, about

1.3 m above the ground. Align the cart and collimator directly in front of the source and position so as to obtain a distance $R = 137$ cm from the face of the NaI probe to the source. Block the wheels on the cart. Take a 30-s count and record as A under the column heading $\ell = 0$ and in row labeled $d = 5.08$ cm in Table 4A.1. Remove the source and take two 30-s background counts and average them.

$$B_1 = \underline{\hspace{2cm}} \quad B_2 = \underline{\hspace{2cm}} \quad \bar{B} = \underline{\hspace{2cm}} \text{ counts/30}$$

Now carefully tape the source a distance of $\ell = 46$ cm from the detector's centerline. Take a 30-s count and record under A in the proper row and column of Table 4A.1. Being careful not to change the forward alignment of the collimator, adjust the collimator depth to $d = 0$, take another 30-s count, and record. Repeat for collimator depths of 1.27, 2.54, 3.81, 6.35, and 7.62 cm. Return the source to the $\ell = 0$ position and take a 30-s count at $d = 7.62$ cm. Time being of essence, the remainder of data under the column $\ell = 0$ need not be taken since N will not change appreciably.

From the data in Table 4A.1, estimate the collimator depth d which is expected to yield a lateral definition of 91 cm at $R = 137$ cm.

$$d = \underline{\hspace{2cm}} \text{ cm}$$

D. Set the collimator depth to this value. Readjust the detector-to-source distance such that $R = 137$ cm. Generate a relative lateral efficiency curve by taking 30-s counts of the source when positioned at intervals $\Delta\ell$ of 20.3 cm from the detector centerline. Begin at $\ell = 0$ and continue taking data until the net count N drops below the background level \bar{B} . Record the results in Table 4A.2. Using the relationship for the detection efficiency

$$\epsilon_i = \frac{N_i}{S\Delta t} \quad , \quad (4A.10)$$

TABLE 4A.1
COLLIMATOR ADJUSTMENT

Collimator Depth d (cm)	$\ell = 0$				$\ell = 45.7$ cm					
	A	-	\bar{B}	=	N	A	-	\bar{B}	=	N
0	-	-	=	-	-	-	-	=	-	-
1.27	-	-	=	-	-	-	-	=	-	-
2.54	-	-	=	-	-	-	-	=	-	-
3.81	-	-	=	-	-	-	-	=	-	-
5.08	-	-	=	-	-	-	-	=	-	-
6.35	-	-	=	-	-	-	-	=	-	-
7.62	-	-	=	-	-	-	-	=	-	-

TABLE 4A.2
LATERAL DETECTION EFFICIENCY

R = 137 cm d = _____ cm $\epsilon_0(R) =$ _____ cpm/g^{235U}

<u>i</u>	<u>l (cm)</u>	<u>A_i</u>	-	<u>B_i</u>	=	<u>N_i</u>	<u>ϵ_i/ϵ_0</u>
0	0		-		=		$N_i/N_0 =$
1	20.3		-		=		
2	40.6		-		=		
3	61.0		-		=		
4	81.3		-		=		
5	101.6		-		=		
6	121.9		-		=		
7	142.2		-		=		
8	162.6		-		=		

where S is the effective ^{235U} source strength (in g ^{235U}) of the calibration source and N_i is the net count over the time interval Δt at lateral position i, calculate ε_i in terms of counts per min per g ^{235U} for all data points. Calculate the relative lateral efficiency ε_i/ε₀ by computing N_i/N₀. Plot ε_i/ε₀ vs l in Fig. 4A.6, and sketch a curve through the points. Graphically determine L/2, hence L. Calculate the collimation angle θ, using Eq. (4A.3). Record all information in Fig. 4A.6.

E. Repeat part D with R = 183 cm, using Table 4A.3 and Fig. 4A.7 to record the data.

F. From the values of ε₀(R) and L(R) obtained at R = 137 cm, calculate these quantities for R = 183 cm, using Eqs. (4A.4) and (4A.5). Compare with the value measured experimentally. Use Table 4A.4 to record the results. How do they compare?

Is the collimation angle θ dependent on R? _____

With the collimator as presently adjusted, what distance R₁ should one use to measure a duct in order to obtain the best resolution over a 91-cm interval?

R₁ = _____ cm

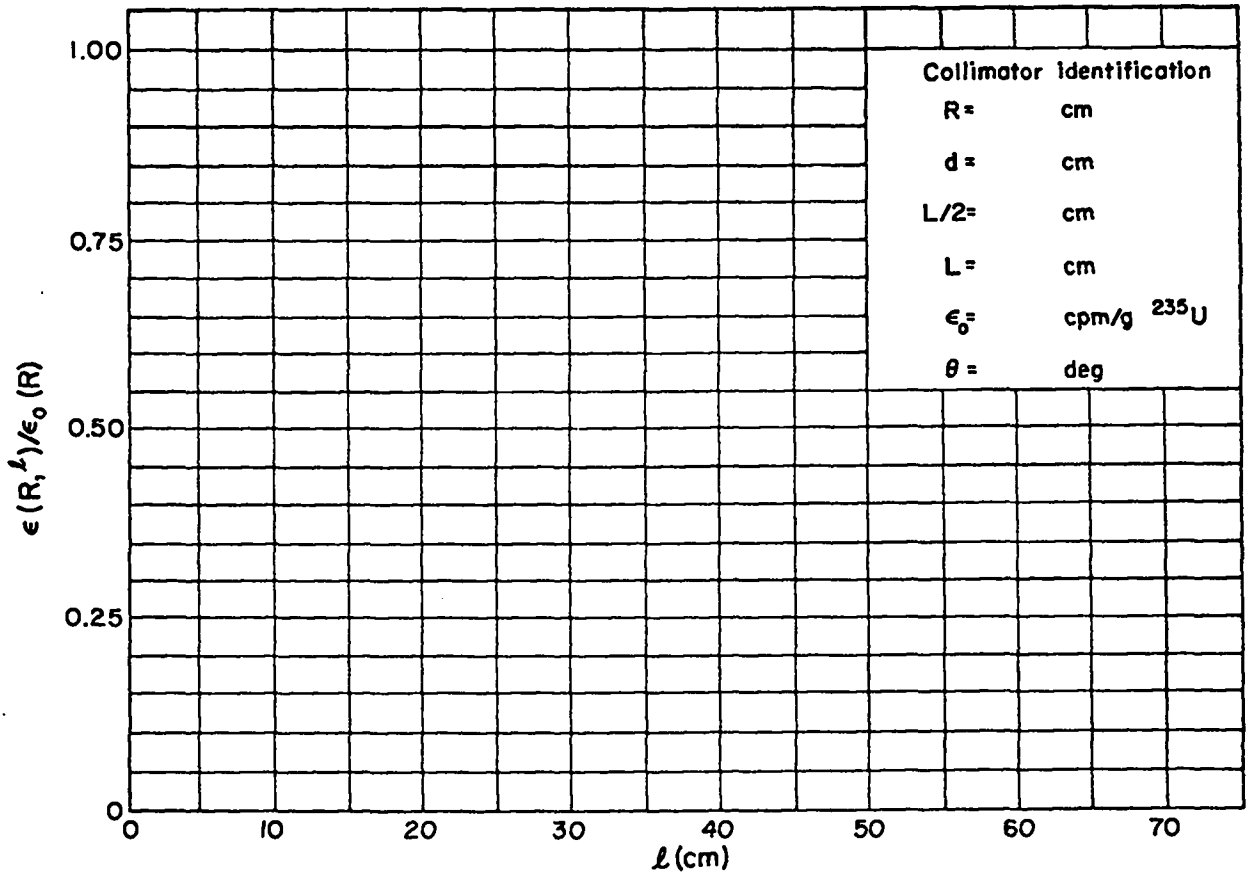

Fig. 4A.6. Relative detection efficiency vs lateral distance from detector centerline.

TABLE 4A.3
LATERAL DETECTION EFFICIENCY

R = 183 cm d = _____ cm $\epsilon_0(R) =$ _____ cpm/g²³⁵U

<u>i</u>	<u>l (cm)</u>	<u>A_i</u>	-	<u>B_i</u>	=	<u>N_i</u>	<u>ϵ_i/ϵ_0</u>
0	0			-		=	
1	20.3			-		=	
2	40.6			-		=	
3	61.0			-		=	
4	81.3			-		=	
5	101.6			-		=	
6	122.0			-		=	
7	142.3			-		=	
8	162.6			-		=	

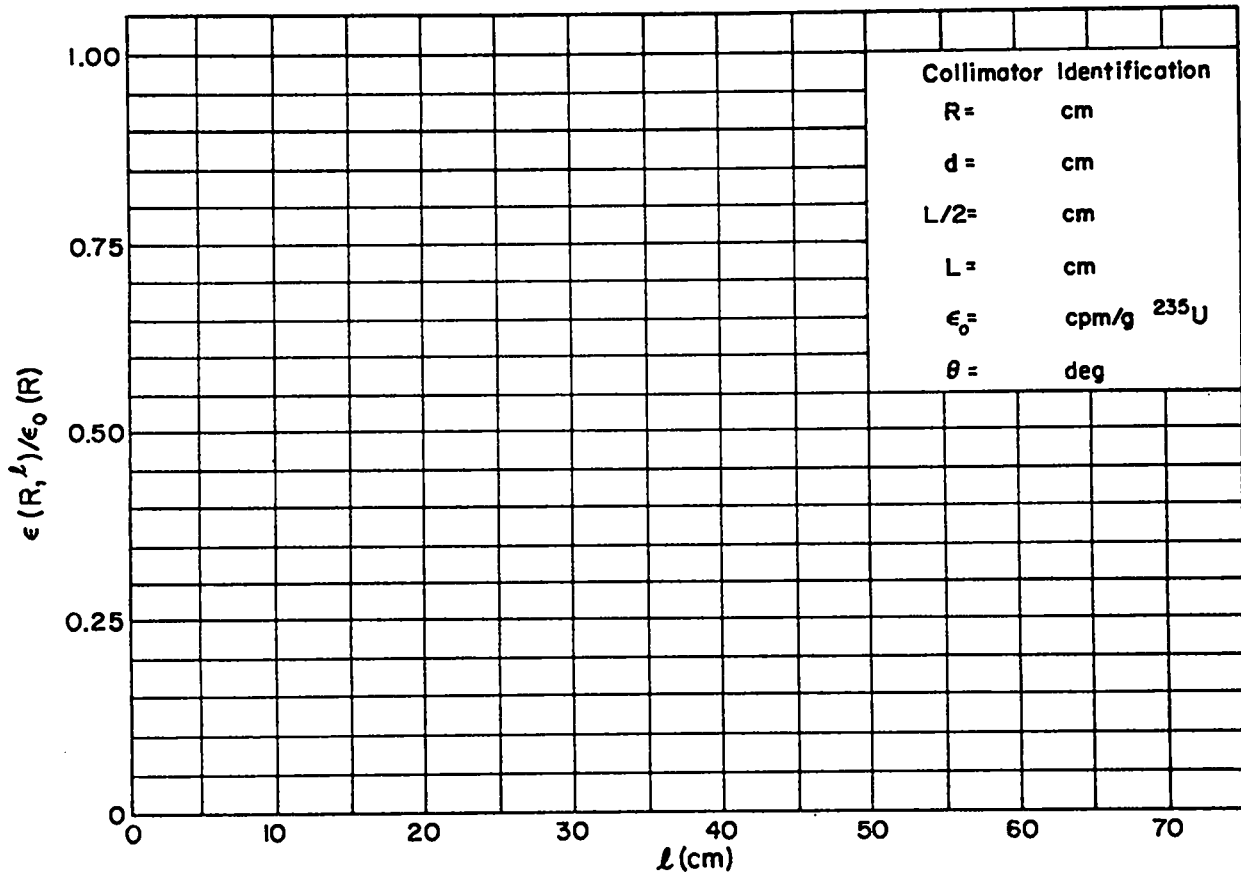

Fig. 4A.7. Relative detection efficiency vs lateral distance from detector centerline.

TABLE 4A.4
 COLLIMATOR FIELD OF VIEW AND ANGULAR RESOLUTION

<u>R (cm)</u>	<u>ϵ_o cpm/g²³⁵U</u>		<u>L (cm)</u>		<u>θ (°)</u>
	<u>Calc</u>	<u>Meas</u>	<u>Calc</u>	<u>Meas</u>	<u>Meas</u>
91					
137	--		--		
183					

$$L(R_1) = \frac{R_1}{R} L(R) \tag{4A.4}$$

$$\epsilon_o(R_1) = \left(\frac{R}{R_1}\right)^2 \epsilon_o(R) \tag{4A.5}$$

V. MEASUREMENT OF ^{235}U HOLDUP IN A DUCT

A. Bring the cart into the shop area. Run a quick gain check on the SAM unit. Calibrate the detector at the distance R_1 which yields a value for L of 91 cm. Take 1-min counts of both the background and the source. Calculate ϵ_o at R_1 .

$$\frac{A}{\epsilon_o(R_1)} = \frac{B}{\epsilon_o(R_1)} = \frac{N}{S\Delta t}$$

$$\epsilon_o(R_1) = \frac{N}{S\Delta t} = \text{_____ counts per min per g } ^{235}\text{U}$$

B. Begin measurements on the duct. Position the cart and aim the detector at the centerline of the duct as illustrated in Fig. 4A.4. Take a 1-min count of the duct, labeling the result A.

$$A = \text{_____ counts/min}$$

Put the transmission source in a plastic bag to avoid contaminating it, and position the calibration source on the outside of the duct, at a position diametrically opposite the point where the detector centerline intersects the duct. Take a 1-min count, labeling the result W.

$$W = \text{_____ counts/min}$$

In this measurement, the net response to the source is simply $I = W - A$. If the attenuation were zero (i.e., if the duct were removed), what would be the net response to the source for a 1-min count?

(Keep in mind that the source is a distance $R_1 + D/2$ from the detector.)

$$\begin{aligned} \text{Unattenuated response } I_o(R = R_1 + D/2) &= S \left(\frac{R_1}{R_1 + D/2} \right)^2 \epsilon_o(R_1) & (4A.11) \\ &= \frac{S \epsilon_o(R_1)}{[1 + D/(2R_1)]^2} \end{aligned}$$

Thus the overall transmission T' is

$$\begin{aligned} T' = \frac{I}{I_o} &= \frac{(W - A)[1 + D/(2R_1)]^2}{S \epsilon_o(R_1)} & (4A.12) \\ &= \text{_____} = \text{_____} \end{aligned}$$

Remove the source from the duct and measure the ambient background by taking a 1-min count with the detector pointed away from the duct, labeling the result B. (Be careful that you are not pointing it at some other hot spot in the area.)

$$B = \underline{\hspace{2cm}} \text{ counts/min}$$

The net response to the holdup material localized in the 91-cm section of duct being assayed is then $N = A - B$.

The actual concentration of ^{235}U holdup can now be calculated using Eqs. (4A.7), (4A.8), and (4A.12). Record the data and the calculational results in Table 4A.5. First calculate T' using Eq. (4A.12). Next calculate CF' according to Eq. (4A.8).

For practice, calculate CF' according to Eq. (4A.9) which assumes that the amount of holdup material is small. The ducts are made of steel ($\rho \approx 7.87 \text{ g/cm}^3$) plate 0.076 cm thick. Assume $\mu_s \approx 0.16 \text{ cm}^2/\text{g}$ for 186-keV photons. Evaluate Eq. (4A.9).

$$CF' = e^{-\mu_s x} \tag{4A.9}$$

$$= \underline{\hspace{2cm}}$$

How does this CF' compare with that determined from Eq. (4A.8) and recorded in Table 4A.5?

The average concentration of ^{235}U holdup over the section of duct assayed can now be calculated using Eq. (4A.6). Repeating the measurement procedure outlined above, proceed to measure the duct at intervals of 91 cm for as long as time permits.

LABORATORY NO. 4B

MEASUREMENT OF LARGE-VOLUME AIR FILTERS

I. INTRODUCTION

This laboratory will deal with the assay of highly enriched ($\sim 93\%$ ^{235}U) uranium trapped in large (61- by 61- by 30.5-cm) air filters. The filters will be assayed off-line rather than in place. The first portion of the lab session will be devoted to the setup and calibration of a NaI detector. The last part of the session will involve actual measurement of the ^{235}U holdup in the air filter.

II. EQUIPMENT

- A. Eberline SAM I or II with 5.08- by 1.27-cm NaI probe
- B. Adjustable lead shield and collimator for NaI probe
- C. Uranium-235 calibration source
- D. Tape rule, tape
- E. Hand calculator

III. PRELIMINARY DISCUSSION

Assume that one needs to measure the ^{235}U holdup in an air filter. Also assume that the filter can be removed and assayed off-line. Set up the detector as shown in Fig. 4B.1, with the detector face even with the lead shield (i.e., minimum collimation) and the detection distance R , from the detector face to the geometric center of the filter equal to 1.5 m. By calibrating the detector at the center of the filter (see Fig. 4B.1), the assay error due to varying distances ("R² effects") is $\leq 26\%$. But by turning the filter around and assaying again from the opposite side, then averaging the two results, the maximum error due to "R² effects" is $\leq 5\%$. You can convince yourself of this by calculating the various responses at positions A through F (Fig. 4B.1) relative to that found at position A, the geometric center of the filter. The relative responses are calculated by

$$\left(\frac{R_A}{R_i}\right)^2, \quad i = A, B, \dots, F \quad (4B.1)$$

Using $R_A = 1.5$ m and the filter size used in Fig. 4B.1, calculate $(R_A/R_i)^2$ for positions A through F and record in Table 4B.1. Next calculate and record the average of the relative responses at B and C, and also at D and E. How do they compare with the response at A?

The calculations show that a single standard calibration source placed at a distance of 1.5 m on the centerline of the detector can yield an excellent calibration for the response of the entire filter. Of course this response must then be corrected for attenuation within the filter.

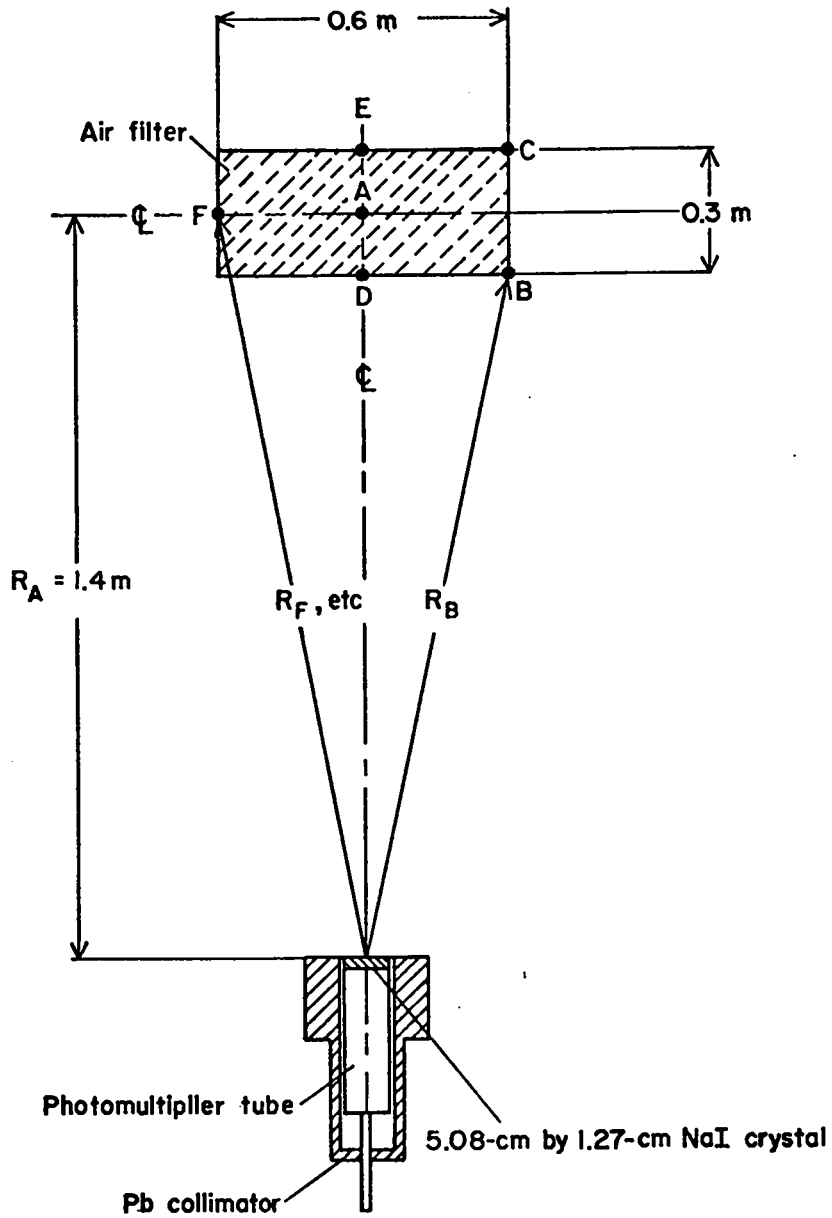

Fig. 4B.1. Top and side view of detector-air filter geometry.

TABLE 4B.1
RELATIVE RESPONSE FOR VARIOUS FILTER POSITIONS^a

Position <i>i</i>	R_i	$(R_A/R_i)^2$		$\frac{1}{2} \left[\left(\frac{R_A}{R_B} \right)^2 + \left(\frac{R_A}{R_C} \right)^2 \right]$	$\frac{1}{2} \left[\left(\frac{R_A}{R_D} \right)^2 + \left(\frac{R_A}{R_E} \right)^2 \right]$
A	1.5 m	1.0			
B	_____	_____			
C	_____	_____			
D	_____	_____		_____	_____
E	_____	_____			
F	_____	_____			

^a See Fig. 4B.1.

The concentration of uranium in the filter can now be expressed as

$$G \text{ (grams)} = \frac{N}{K} CF' \quad , \quad (4B.2)$$

where N is the net ^{235}U count rate per minute (background subtracted) and K is the calibration constant for the 1.5-m detector distance. The constant K is expressed in units of counts per min per g ^{235}U . CF' is the correction factor for gamma-ray absorption in the filter matrix and the trapped material itself.

Assuming uniform distribution of the material over the filter and no "lumps", the correction factor CF' can most readily be determined by the use of the transmission-source technique. When the transmission T' is measured, the source should be placed on the back surface of the filter opposite the point on the filter at which the detector is aimed. One then calculates CF' as

$$CF' = 1/\sqrt{T'} \quad , \quad (4B.3)$$

which is the inverse of the transmission from the center of the filter to the surface of the filter face.

IV. PROCEDURE FOR SETUP, COLLIMATOR ADJUSTMENT, AND CALIBRATION

A. Set up the SAM unit for single-channel analysis of the 186-keV peak from ^{235}U as outlined in Laboratory 3. A 0.08-cm foil of cadmium should be taped to the face of the NaI probe to cut out low-energy x rays and gamma rays.

B. Find an area where the gamma background is relatively low and where it will most likely remain constant over the next hour. Observing the count rate meter on the SAM, directionally scan the area to acquaint oneself with the whereabouts of any hot spots.

C. Position the movable shield on the collimators such that it is flush with the front. Position the face of the NaI probe so that its face is even with the front of the collimator. Next tape the ^{235}U calibration source to a wall, even with the detector height. Align the detector directly in front of the source and position it so as to obtain a distance $R = 137$ cm from the face of the NaI probe to the source. Take 1 60-s count and record under position A in Table 4B.2. Remove the source and take two 60-s background counts and average them. Record them in Table 4B.2. Now carefully tape the source a lateral distance of 30.5 cm from the detector's centerline. Take a 60-s count and record under position F in Table 4B.2. Next calculate the source signal at A and F by subtracting the background. Record these signals in Table 4B.2. How does the signal at position A compare with that at position F?

From Table 4B.2 calculate the calibration constant K and record in Table 4B.2. The detection system is now calibrated and ready to assay filters.

TABLE 4B.2
CALIBRATION CONSTANT DETERMINATION

<u>Position i</u>	<u>R_i</u>	<u>Source Counts/min</u>	<u>Bkg Counts/min</u>	<u>Source Signal/min</u>
A	1.5 m	-	-	=
F		-	-	=
Avg Bkg =				
		Source mass =	_____ g ^{235}U	
		$K(R_A=1.5\text{m})$	= _____ counts per min per g ^{235}U	

V. MEASUREMENT OF ^{235}U HOLDUP IN FILTERS

A. Place the filter in front of the detector at a distance of $R = 1.5$ m between the detector face and the geometric center of the filter. Take a 60-s count of the filter and record in Table 4B.3 as A_1 . Next turn the filter 180° and take a 60-s count of the filter's second side and record in Table 4B.3 as A_2 . (Be sure that $R = 1.5$ m after turning the filter around.) Average A_1 and A_2 and record in Table 4B.3 as \bar{A} , the average total yield from the filter. Next, remove the filter from the area and record the ambient background. Repeat this and record the two backgrounds as B_1 and B_2 in Table 4B.3. Average these two results and record as \bar{B} . Subtract \bar{B} from \bar{A} and enter in Table 4B.3 as the net signal, N .

TABLE 4B.3
AIR FILTER SIGNAL ($R = 1.5$ m)

<u>Filter ID</u>	<u>A_1</u>	<u>A_2</u>	<u>\bar{A}</u>	<u>B_1</u>	<u>B_2</u>	<u>\bar{B}</u>	<u>$N \equiv \bar{A} - \bar{B}$</u>
------------------	-------------------------	-------------------------	-----------------------------	-------------------------	-------------------------	-----------------------------	--

B. The correction factor CF' is determined by placing the filter back at $R = 1.5$ m with the original side facing the detector. Tape the transmission source to a wall behind the filter opposite the spot at which the detector is aimed. Take a 60-s measurement and record in Table 4B.4 as A_1' . Transfer the A_1 value from Table 4B.3 to Table 4B.4. Next calculate $I \equiv A_1' - A_1$, which is the background-corrected transmission signal through the filter. Now remove the filter from the area, leaving the transmission source in place. Next take a 60-s measurement of the transmission source and record in Table 4B.4 as A'' . Transfer the value of \bar{B} from Table 4B.3 to Table 4B.4. Calculate $I_0 \equiv A'' - \bar{B}$, which is the background-corrected unattenuated signal through the filter. Calculate, using Eq. (4B.3), the correction factor CF' and record in Table 4B.4 under $CF' = 1/\sqrt{I/I_0}$.

TABLE 4B.4
TRANSMISSION CORRECTION FACTOR

Filter ID	A_1'	A_1	$I \equiv A_1' - A_1$	A''	\bar{B}	$I_o \equiv A'' - \bar{B}$	$CF' = \frac{1}{\sqrt{I/I_o}}$
-----------	--------	-------	-----------------------	-------	-----------	----------------------------	--------------------------------

C. The amount of uranium (^{235}U) in the filter is now determined using Eq. (4B.2) and the values of K, N, and CF' determined earlier and recorded in Tables 4B.2, 4B.3, and 4B.4, respectively. Rerecord these values in Table 4B.5 and calculate G, the ^{235}U holdup. Repeat these measurements on other filters as long as time allows.

TABLE 4B.5
URANIUM-235 HOLDUP DETERMINATIONS

Filter ID	$N \equiv \bar{A} - \bar{B}$	K (counts per min per g ^{235}U)	CF'	G (grams) = $\frac{N}{K} CF'$
-----------	------------------------------	--	-------	-------------------------------

LABORATORY NO. 5

NEUTRON DETECTION WITH PORTABLE INSTRUMENTATION

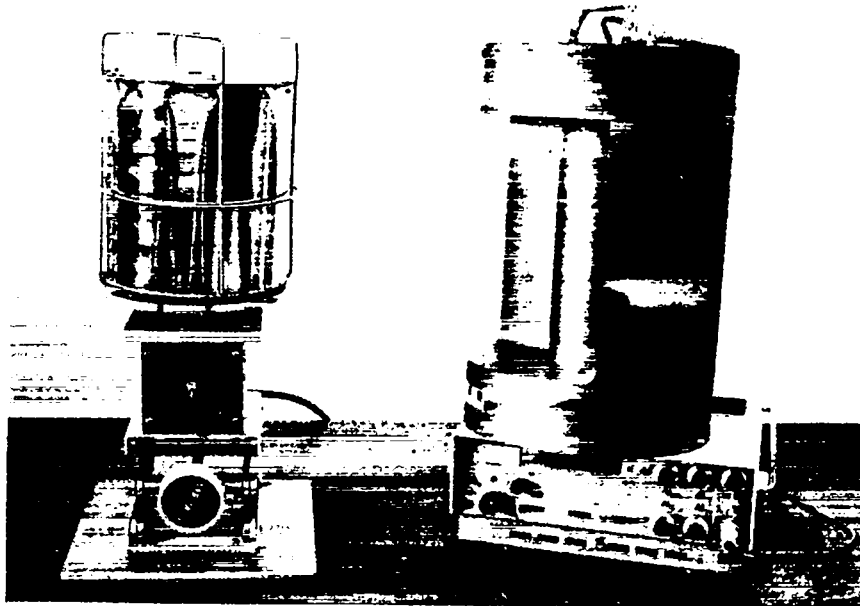

Fig. 5.1. Physical setup of Laboratory 5.

I. GOALS

- A. Gain familiarity with the operation of the SNAP detector coupled to SAM electronics. Observe the pulse-height distribution of a ^3He gas proportional counter.
- B. Measure the properties of the SNAP detector which are important to its use as an assay instrument: efficiency as a function of neutron energy and angle.
- C. Observe the macroscopic interaction of neutrons with materials ranging from lead to polyethylene.

II. EQUIPMENT

- A. Eberline SAM I or II electronic unit
- B. SNAP detector
- C. PuLi , PuLiF , PuBe , AmLi , and ^{252}Cf neutron sources
- D. Containers of lead, iron, SiO_2 , and CH_2
- E. Oscilloscope
- F. Lab jack, meter stick, ring stand, sample rotator

III. PULSE SHAPES, SPECTRA, AND OPERATING CHARACTERISTICS OF ^3He NEUTRON COUNTERS

Reference: Secs. 8.2 and 8.4 of Manual

A. Examine the components comprising the SNAP detector. Connect the detector to the SAM unit using the hv connector labeled N. Check to see that stabilizer is off and that the GAIN switch is on N. Place a neutron source in front of SNAP. With the AMP OUT terminal connected to the scope input, raise the high voltage until the majority of observed pulses are 0.6 V in amplitude, a level which puts the peak of the spectrum well within the discriminator circuitry of the SAM unit. The high voltage output of the SAM unit is approximately 200 times the hv setting.

$$\text{hv setting} = \underline{\hspace{2cm}} \quad \text{hv} \approx \underline{\hspace{2cm}} \text{ volts}$$

The firing of the SCA circuitry on the SAM units causes distortion on the trailing edge of the pulse, but it is of little or no consequence since it occurs after the pulse has been analyzed. However, when recording the pulse-height spectrum with a multichannel analyzer, it is recommended that the threshold be raised to 10.0 in order to eliminate the distortion on the amplifier signals.

B. Position the source such that for a threshold setting of $T = 3.00$, the count rate is $\sim 10^5$ counts/min. Set the window width ΔT at 0.40 and take a pulse-height spectrum starting at $T = 0.80$, using count times of 0.2 min.

Plot the results on graph paper and ascertain the resolution and the location of the $^3\text{He}(n,p)^3\text{H}$ peak, denoted T_p . A quick scan with the ratemeter will give the scale for the plot. Note the asymmetric shape.

$$\text{FWHM} = \underline{\hspace{2cm}} \quad T_p = \underline{\hspace{2cm}}$$

$$\text{Resolution} = \frac{\text{FWHM}}{T_p} = \underline{\hspace{2cm}} \%$$

C. To discriminate $^3\text{He}(n,p)^3\text{H}$ reactions from noise and pileup gamma-ray events, a good rule of thumb is to set the threshold at $T = \frac{1}{2} T_p$.

$$T = \underline{\hspace{2cm}}$$

Set the threshold at T and switch the window OUT. The SAM unit is now set up for neutron counting. All pulses greater in amplitude than the threshold setting will be counted.

D. The gain of a ^3He detector is strongly dependent upon the high voltage on the anode of the tube. Therefore, it is good practice to perform gain checks periodically, just as when gamma-ray probes are used. The $\frac{1}{2}$ -max method learned earlier is a quick and sensitive check. Determine the threshold setting which cuts the count rate to half the value when the threshold is set at T .

$$T_{\frac{1}{2}} = \underline{\hspace{2cm}}$$

The SNAP detector is now ready to be used.

IV. MEASUREMENT OF EFFICIENCY AS A FUNCTION OF NEUTRON ENERGY, ANGLE, AND DISTANCE FROM DETECTOR

A. Efficiency as a Function of Distance

Position the neutron source 50 cm from the front face of the detector and take a 2-min count. Move the source successively closer to the detector, taking counts at five intermediate distances.

Source _____	S = _____
Distance R _____ (cm)	Count C $\sqrt{C + \text{Bkg}}$
Bkg (no source)	
50	
40	
30	
20	
10	

Plot these data. Assuming the efficiency varies as $1/(R + p)^2$ where R is the distance to the detector face and p is a constant having to do with an effective penetration into the detector, then

$$C = \frac{S \epsilon_{\text{int}} A}{(R + p)^2} \quad (5.1)$$

where

- S = neutron source strength in units of n/s,
- ϵ_{int} = intrinsic detector efficiency,
- A = area of detector.

To solve for p and ϵ_{int} , first assume p is small compared to 50 cm and solve for ϵ_{int} using the data for the 50-cm distance.

$$\epsilon_{\text{int}} \Big|_1 \cong \frac{[C(50)] (50)^2}{SA} \quad (5.2)$$

Using this value for ϵ_{int} , solve for p using the 10-cm data point.

$$p \cong \sqrt{\frac{S \epsilon_{\text{int}} \Big|_1 A}{C(10)}} - 10 \quad (5.3)$$

Now go back and reanalyze for ϵ_{int} using the value obtained for p.

$$\epsilon_{int} \Big|_2 = \frac{[C(50)] * [50 + p]^2}{SA} \quad . \quad (5.4)$$

Then solve for a new p. One could continue this process any number of times, hopefully getting closer to the correct answer each time. This technique, known as iteration, is used extensively in computer solutions to complicated problems.

You now have an expression relating data taken at different detector-sample distances as well as a plot of this relationship. This expression will depend on neutron energy, in that both ϵ_{int} and p are energy dependent.

B. Efficiency as a Function of Angle

Position the source 50 cm from the detector face and by rotating the detector take counts versus angle at nine angles from 0 to 180°. Take a background reading at angles of 0, 60, 120, and 180°. Is the background constant at all angles? _____

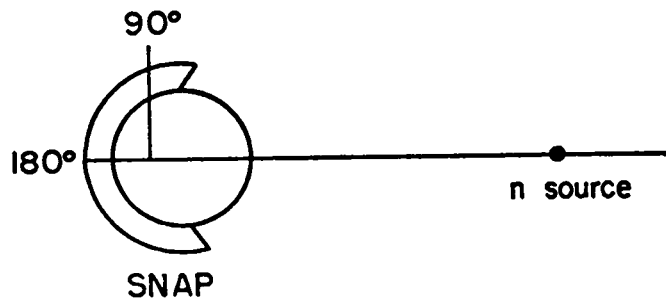

Fig. 5.2. Schematic of the SNAP detector and a neutron source.

Source _____

S = _____

Angle	Count C	$\sqrt{C + \text{Bkg}}$	$\frac{C}{C \text{ at } 0^\circ}$
0			
20			
45			
60			
90			
100			
120			
135			
140			
160			
180			

Plot the data on polar coordinate paper. An obvious conclusion of this study is the advantage gained by pointing the detector away from background sources, e.g., other samples waiting to be measured.

C. Efficiency as a Function of Neutron Energy

For five neutron sources of different average energies placed at 25 cm, measure count rate at 0 and 180°.

Source	\bar{E}_n	S (n/s)	Bkg Subtracted Count Rate		$\frac{\text{C.R.}}{S} = \epsilon_{\text{total}}$	Ratio of 0°/180°
			0°	180°		
Bkg						

- Plot: 1. ϵ_{total} vs \bar{E}_n
2. $0^\circ/180^\circ$ vs \bar{E}_n

As noted in the Manual, the total efficiency ϵ_{total} is not independent of neutron energy. However, note that the front-to-back (0 to 180°) ratio gives a rough idea of the average energy of the neutrons being detected. With this knowledge and the efficiency curve, data can be corrected for differences in energy.

V. NEUTRON COUNTING LABORATORY: THE EFFECT OF MATRIX MATERIAL ON TOTAL NEUTRON COUNTING

A. Introduction

As described in Sec. 7.7 of the Manual, elastic scattering is the predominant interaction process in nonfissionable material for the energy range spanned by passive neutrons (200 keV to several MeV). The maximum energy loss per collision for the neutron is given in the Manual, Table 7.6. This corresponds to a 180° scattering event. For heavy nuclei, elastic scattering can result in a large change of direction with a small change in energy. For the lighter nuclei, e.g., hydrogen, there is a much larger change in neutron energy. Because the type of detector used in passive counting situations is relatively insensitive to neutron energy, the effect of elastic scattering of the neutron count is not as large as would be expected for a calculation of $e^{-\Sigma x}$ (see Sec. 9.1 of the Manual). This will be illustrated in this experiment which will investigate the effect of elastic scattering for matrix materials ranging in Z from lead to CH_2 .

B. Equipment

1. SNAP detector with SAM unit
2. Neutron source
3. Set of 1-gal cans filled with various matrix materials as described in table below
4. Lead brick
5. Polyethylene slab

C. Scattering and Reflection

1. After setting up the SNAP detector, place the neutron source ~ 25 cm from the front face of the detector. Count for 60 s. Record data.
2. Place a lead brick close to source, between the detector and the source. Be careful not to move the source. Count for 60 s.
3. Now place the lead brick behind the source and count.

<u>Configuration</u>	<u>Count/60 s</u>	<u>$\sqrt{\text{Count}}$</u>	<u>$\frac{\text{Count}}{\text{Count (b)}}$</u>
(a) Bkg			
(b) detector-source			
(c) detector-brick-source			
(d) detector-source-brick			

By dividing the counts from (c) and (d) by (b), it is easier to see the effect of the lead scatterer. In case (c), some neutrons that would have struck the detector are scattered away, leading to a lower count. Just the opposite is true for (d); namely, the count increases because neutrons are scattered into the detector. This latter effect is sometimes referred to as reflection.

Your body can be a reflector as well as a moderator. This can be illustrated by placing a polyethylene slab next to the source and comparing counts with and without slab. Concrete walls and floors also act as moderator-reflectors.

<u>Configuration</u>	<u>Count/60 s</u>	<u>$\sqrt{\text{Count}}$</u>	<u>$\frac{\text{Count}}{\text{Count (e)}}$</u>
(e) detector-source			
(f) detector-source-poly			
(g) detector-poly-source			

Run a quick gain check.

Counts at $T = N_1$ _____

$\frac{1}{2} N_1$ _____

Counts at $T_{\frac{1}{2}} = N_2$ _____

Does $N_2 = \frac{1}{2} N_1$? _____

Note: Remember to set threshold back to T_0 .

D. Matrix Studies

- Place the empty 1-gal can on the rotating stand. Place the neutron source in the central hole and count for 2 min at 0° . Repeat at 180° .
- Repeat the procedure for each matrix. Careful, the cans are heavy.

Matrix	Count/60 s		Count		Ratio of 0°/180°	Count
	0°	180°	0°	180°		Count (empty) 0°
Empty can						
Lead						
Iron						
SiO ₂						
Bkg						
CH ₂ (1)						
ρ = _____						
CH ₂ (2)						
ρ = _____						
H ₂ O						

3. Interpretation of the results. Refer to Table 9.2 of the Manual and Table 5.1 below. Two effects must be considered in order to understand the data. First, there is moderation due to elastic scattering. In all of the above cases

TABLE 5.1

DESCRIPTION OF MATRIX MATERIALS

Container: ~ 1-gal can (16.5 cm diam by 19.0 cm high)

Material	Weight (kg)	Density (g/cm ³)	σ_{total} at 1 MeV (barns)	$\Sigma \ell^a$	$1 - e^{-\Sigma \ell}^b$
Lead	26	6.9	~ 5	0.83	0.57
Iron	17	4.4	~ 2.5	0.99	0.63
SiO ₂	6	1.6	~ 4	1.61	0.80
CH ₂ (1)	0.7	--	2.75, 5	--	--
CH ₂ (2)	2.5	0.67	2.75, 5	3.07	0.95
H ₂ O	3.6	1.0	5,4	4.19	0.98

^a $\Sigma \ell = \frac{0.6 \rho}{A} \sigma \ell$, where ℓ = radius of the can and σ is in barns.

^b $1 - e^{-\Sigma \ell}$ = probability of a neutron interacting before it leaves the can.

(except for the empty) the probability for a neutron to scatter more than once is substantial. For example, the probability for a single collision in the iron-filled can is roughly 63%; the chance of a second collision is (very) roughly $(0.63)^2$ or 40%. Thus moderation is taking place in a degree which is dependent on the weight of the scattering nucleus (see Manual, Table 7.6). The second effect is the detector efficiency versus neutron energy. In the SNAP unit these slightly lower-energy neutrons are then detected with greater efficiency and the count goes up.

For the hydrogenous material the count rate increased at the lowest density, but as more hydrogen is added the rate decreases. With the higher-density sample, a greater number of the neutrons are moderated to the point where they are absorbed before they reach the detector tubes. They can be absorbed by the cadmium cover of the SNAP unit or by the hydrogen itself, either in the sample or in the detector.

Using the front-to-back ratios, correct each count by (1) determining an average neutron energy coming out of the matrix cans, and (2) multiplying the count rate by the ratio of $\epsilon(\bar{E}_n)$ for the empty can to the $\epsilon(\bar{E}_n)$ for each matrix.

<u>Matrix</u>	\bar{E}_n	$\frac{\epsilon(\text{empty})}{\epsilon(\text{matrix})}$	<u>Corrected Count</u>
---------------	-------------	--	----------------------------

The SNAP detector was designed for a specific situation in which the matrix material did not vary. It is possible to modify the SNAP detector design to make its efficiency less energy dependent with a small increase in weight. East and Walton describe other detectors which have been designed for assay purposes.¹ However, the detectors described therein are rather heavy, and wheelable, but not portable.

¹ L. V. East and R. B. Walton, "Polyethylene Moderated ³He Neutron Detectors," Nucl. Instrum. Methods 72, 161 (1969).

4
2

4
2

LABORATORY NO. 6

TOTAL NEUTRON COUNTING OF PLUTONIUM AND URANIUM SAMPLES

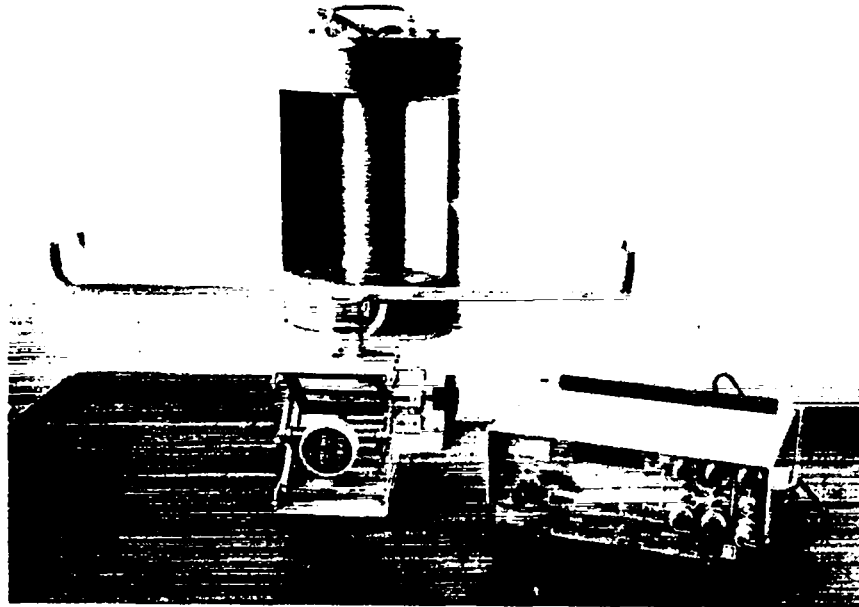

Fig. 6.1. Physical setup of Laboratory 6.

I. PLUTONIUM METAL BUTTONS

A. The plutonium metal button represents a situation in which the gamma signatures cannot be used for determination of total plutonium because of severe attenuation. If the plutonium isotopic is known or constant for a group of buttons, the neutron emission can be used for quantitative verification measurements. Two potential problem areas can arise because: (1) the neutron emission is dominated by the nonfissile (i.e., fertile) isotopes, and (2) light element impurities, e.g., fluorine, can influence the measurement through (α, n) emission. Multiplication effects are significant and dependent on, among other things, the shape of the buttons. Refer to Sec. 9.2 of the Manual and the work of Atwell et al.¹ In this experiment we will measure a number of plutonium buttons of different shapes and different weights, illustrating the neutron signatures and the multiplication effects.

B. Set up SAM unit and SNAP detector for neutron counting as performed in Laboratory 5.III. Position the center of the sample rotator a distance of 25 cm from the front face of the detector and adjust the height of the rotator to be

¹ T. L. Atwell, D. B. Smith, and A. C. Walker, Los Alamos Scientific Laboratory A-1 Progress Report LA-5431-PR (1973), p. 20. The title of this article is "Assay of Plutonium Metal Buttons with a Portable Neutron Counter."

10 cm above the base of SNAP. Making sure that sources and samples are removed from the experimental area, take a 2-min background count and calculate the background count rate B.

Count = _____

TABLE 6.1
TYPICAL ISOTOPIC COMPOSITION OF LABORATORY MATERIAL

	I (wt%)
^{238}Pu	0.01
^{239}Pu	93.67
^{240}Pu	5.89
^{241}Pu	0.41
^{242}Pu	0.06
^{241}Am	0.08

Table 6.1 gives a typical isotopic composition for the material that will be used for this experiment. From Tables 7.3 and 7.4 in the Manual, calculate the expected yield from plutonium metal, PuO_2 , and PuF_4 for 1 g of plutonium.

Isotope	In 1 g of Plutonium (g)	Plutonium (SF)	SF + (α, n)	
			PuO_2	PuF_4
^{238}Pu	0.0001			
^{239}Pu	0.9367			
^{240}Pu	0.0589			
^{241}Pu	0.0041			
^{242}Pu	0.0002			
^{241}Am	0.0008			

Total expected yield:

C. Now measure the output for cans of metal, PuO_2 , and PuF_4 .

Can ID	Plutonium (g)	Count/2 min	Count/g Pu
Metal	585		
PuO_2			
PuF_4	350		

D. To illustrate the multiplication effect as a function of plutonium mass, measure the neutron output of samples 621 and 620. The radiographs show that they are in the shape of right circular cylinders with button 621 twice as high as 620.

<u>Sample</u>	<u>Plutonium (g)</u>	<u>Count-Bkg</u>	<u>Count/g Pu</u>	<u>% ²⁴⁰Pu</u>
620	1000			5.7
621	2001			5.7

The count per gram plutonium is greater for button 621, indicating an appreciable multiplication.



Fig. 6.2. Radiographs of buttons 621 and 620, in the shape of right circular cylinders.

E. Count the remaining buttons, and examine the radiographs shown in Fig. 6.3. Their shape is more of a pancake as opposed to a right circular cylinder. Compare the count/g for these buttons to that of buttons 620 and 621. Is the difference explainable? See Table 9.3 in the Manual.

<u>Sample ID</u>	<u>% ²⁴⁰Pu</u>	<u>Count-Bkg</u>	<u>Plutonium (g)</u>
Fabricator No. 1			
643-3	5.9		1179
643-5	5.9		
Fabricator No. 2			
643-1	5.1		
643-2	5.1		



Fig. 6.3. Radiographs of buttons 643-2 and 643-3, pancake shaped. Filmy lines above the button are due to a knotted plastic bag. The dark specks are bits of plutonium oxide which have flaked off the button.

II. PLUTONIUM RECYCLE BWR-TYPE FUEL RODS

A. Because the external appearance of bundles containing 3% enriched uranium BWR rods is identical to those containing plutonium recycle mixed oxide fuel, the inspector's task is to verify that each bundle contains what the tag claims is in that bundle. Position the holder approximately 10 cm from the SNAP unit. Using bundle no. 1 as a comparison standard, count each bundle and verify the plutonium content, making the assumption that the plutonium isotopic composition is the same for all rods.

<u>Rod Bundle ID</u>	<u>Count</u>	<u>Count - Bkg</u>	<u>$\sqrt{\text{Count} + \text{Bkg}}$</u>	<u>Plutonium Mass (g)</u>
Bkg				0
1				179.4
2				
3				
4				
5				
6				

B. These particular BWR rods contain 2.3 wt% PuO₂ and 97.7 wt% natural uranium dioxide. The plutonium isotopic is approximately:

	<u>I (wt%)</u>
²³⁸ Pu	0.28
²³⁹ Pu	75.52
²⁴⁰ Pu	18.12
²⁴¹ Pu †	5.00
²⁴² Pu	1.09
²⁴¹ Am	?

Table 6.2 (which is Table 9.1 from the Manual reproduced) gives an estimate of the neutron emission contribution from each isotope. The total emission rate for bundle no. 1 is approximately (3.2 x 10⁴) times (179.4/100) = 5.7 x 10⁴ n/s. Percentagewise the isotopic contributions to the neutron emission rate are:

²³⁸ Pu	16%
²³⁹ Pu	11
²⁴⁰ Pu	68
²⁴¹ Pu	~ 0
²⁴² Pu	5

TABLE 6.2
NEUTRON EMISSION RATES FOR PLUTONIUM METAL, PuO₂

<u>Isotope</u>	<u>Wt%</u>	<u>Neutron Rate for 100 g of Pu (n/s)</u>	
		<u>Metal</u> <u>(Spontaneous Fission)</u>	<u>PuO₂</u> <u>(α,n)</u>
²³⁸ Pu	0.3	746	4 200
²³⁹ Pu	75.6	2	3 400
²⁴⁰ Pu	18.0	18 400	3 060
²⁴¹ Pu	5.0	~ 0	50
²⁴² Pu	1.1	1 900	10
	Total	<u>21 048</u>	<u>10 720</u>

† Plutonium-241 β decays to ²⁴¹Am with a T_{1/2} = 13 y. Therefore, ²⁴¹Am is growing in at an appreciable rate, increasing the neutron output.

C. Note that for a more accurate assay, one could scan the bundle past the SNAP or alternatively move the SNAP past the bundle. This is important when the bundle is 3- to 4-m long. Remembering the measurements of Laboratory 5 with the lead matrix can, this type of verification measurement could be made external to a high-Z, e.g., lead, shielding container.

III. NEUTRON COUNTING OF UF₆ CYLINDERS

A. Introduction

Consult pp. 71-72 of the Manual and pp. 133-138 of Ref. 9.3² in the Manual on counting of UF₆ cylinders. In this laboratory the three 5A cylinders used earlier for enrichment measurements will be counted. Leave the 5A cylinders on their carts and move the SNAP detector to about 76 cm off the floor. (Sample-detector distance is ~ 30 cm.) An accurate background measurement with no sample may be necessary in some locations. Count each sample for 5 min.

<u>Cylinder No.</u>	<u>Count/5 min</u>
Bkg	
0311	
1502	
0217	

Table 6.3 gives the isotopic composition of the UF₆ in each cylinder. Based on this composition and the yields in Table 9.4 of the Manual, Table 6.4 calculates the expected yield for each isotope in the three cylinders.

TABLE 6.3
WEIGHT PERCENT ISOTOPIC ANALYSIS AND
URANIUM CONTENT OF "5A" CYLINDERS

<u>Cylinder No.</u>	<u>Mass Uranium (kg)</u>	<u>235U (%)</u>	<u>234U (%)</u>	<u>236U (%)</u>	<u>238U (%)</u>
0133	15.03	19.94	0.10	0.14	79.82
1502	13.80	46.80	0.52	0.15	52.53
0217	15.22	97.64	0.75	0.22	1.39

² R. B. Walton, T. D. Reilly, J. L. Parker, J. H. Menzel, E. D. Marshall, and L. W. Fields, "Measurements of UF₆ Cylinders with Portable Instruments," Nucl. Tech. 21, No. 2, 133 (1974).

TABLE 6.4
 EXPECTED ISOTOPIC YIELD OF "5A" CYLINDERS

Cylinder No.	n/s				Total	Normalized
	$^{234}\text{UF}_6$	$^{235}\text{UF}_6$	$^{236}\text{UF}_6$	$^{238}\text{UF}_6$ + SF		
0133	8 700	365	83	287	9 435	1.00
1502	41 620	788	82	173	42 663	4.52
0217	66 207	1 813	132	--	68 152	7.22

Note the dominance of the ^{234}U contribution.

B. Using the efficiency of the SNAP unit for the PuLiF source and a distance of 30 cm, calculate the expected count rate and compare with the measurements.

Cylinder	Count Rate			Measured
	Calculated	F_M	C.R. * F_M	
0133				
1502				
0217				

The multiplication in the cylinders can be estimated from the expression:

$$F_M = 1 + aM(bI_5 + 100 - I_5)$$

where

$$a = 9.8 \times 10^{-8} \text{ per g,}$$

$$b = 2.1,$$

$$I_5 = ^{235}\text{U enrichment in \%},$$

$$M = \text{total uranium mass in g.}$$

Calculate F_M for each cylinder and multiply the calculated count rate by F_M .