

UNCLASSIFIED

SECRET
SECRET

[REDACTED]

[REDACTED]

[REDACTED]

LA - 383

THIS IS COPY 3 OF 18

**CIC-14 REPORT COLLECTION
REPRODUCTION
COPY**

NOTE

[REDACTED]
This document must be kept in a secure location. Transmitted copies of the document must be kept in a secure location. It must not be left unattended or where an unauthorized person could have access to it. When not in use, it must be stored in a secure container. While this document is in your possession, you must sign a receipt upon its receipt. It is your responsibility to ensure the information contained herein is not compromised.

THE INFORMATION CONTAINED IN THIS DOCUMENT IS UNCLASSIFIED EXCEPT WHERE SHOWN OTHERWISE. DON'T GET IT THROUGH YOUR NEGLIGENCE.

[REDACTED]

SCANNED 11/1/86

LOS ALAMOS NATIONAL LABORATORY
3 9338 00350 2761

SECRET
SECRET

UNCLASSIFIED

DECLASSIFIED

UNCLASSIFIED

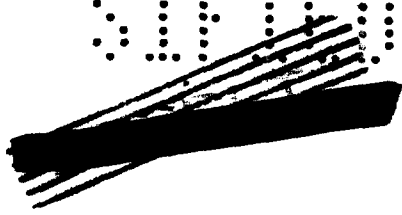

VERIFIED UNCLASSIFIED

PUBLICLY RELEASABLE

Per 2MS 6-11-79

Per Phillip J. Jorg, FSS-16 Date: 3-27-96

By TD Ballagoo 4-17-96

By Maria Ballagoo CIC-14 Date: 4-17-96

LA REPORT 383

This is copy 3 of 18 copies

September 10, 1945

This document contains 39 pages

ELECTRONIC TIMING METHODS FOR USE IN HIGH-EXPLOSIVE RESEARCH

WORK DONE BY:

E. W. Titterton

REPORT WRITTEN BY:

E. W. Titterton

Classification changed to UNCLASSIFIED
by authority of the U. S. Atomic Energy Commission.

Per ALDR(TID-1400-52) Sept-Oct 1974

By REPORT LIBRARY [Signature] 2/6/75

LOS ALAMOS NAT. LAB. LIBS.
3 9338 00350 2761

tion... use of the... within the mean-
ing of the Espionage Act... and 32, its
... in any
... by law.

DECLASSIFIED

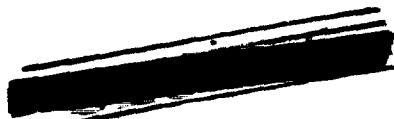

UNCLASSIFIED

DECLASSIFIED

UNCLASSIFIED

-2-

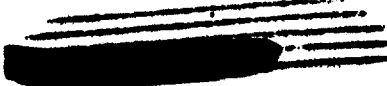

ABSTRACT

The explosive-research program carried out on this project has been greatly facilitated by the use of electronic techniques. Methods have been devised for the measurement of the propagation velocity of detonation wave fronts, researches on electric detonators, investigation of the properties of explosive lenses and other applications. The field of application is by no means limited as yet. The present report describes the principles involved in such methods and discusses a form of electronic equipment which has shown utility on this project.

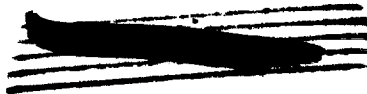

DECLASSIFIED

UNCLASSIFIED

DECLASSIFIED

SECRET
SECRET

UNCLASSIFIED

-3-

ELECTRONIC TIMING METHODS FOR USE IN HIGH-EXPLOSIVE RESEARCH

INTRODUCTION

Some of the problems arising in explosives research can be investigated readily by means of electronic equipment. Perhaps the best-known use of this equipment is in the measurement of the velocity of propagation of the detonation wave in the H.E. Other problems have been the investigations of the properties of explosive lenses and in particular, of the transit time of the detonation wave from the apex of the lens to the surface. A further application has been to find out whether detonation waves in H.E. which are supposed to reach certain positions simultaneously do, indeed, arrive together; if they do not, then a measurement of the time scatter of the instants at which they do arrive is usually desired. More recently the method has been adapted to measure the velocities obtained in Munroe jets.

The present report discusses the principles involved in these methods and describes some electronic equipment which has been designed for such measurements.

PRINCIPLE

In order to obtain electrical signals from a high explosive (e.g., primacord) use is made of the fact that in the detonation wave front the pressure and temperature are high and the gases are ionized. Then, if a pair of electrodes are inserted into the solid H.E. and an electric field is maintained between them, a current flows at the instant when the wave passes between the electrodes. The method has the advantage over the use of mechanical switches in that, if electron collection is used, extremely fast pulses rising in the order of 10^{-8} secs can be obtained at precisely the instant when the wave front reaches the electrodes.

UNCLASSIFIED

UNCLASSIFIED

The older method of placing a pencil lead against the primacord and using the breaking of a circuit as an indication of the passage of the detonation cannot be as consistent as the present method. This is because, among other things, the ionization which makes the present method possible provides a conducting bridge across the opening circuit and destroys the accuracy.

ELECTRODE GEOMETRY IN PRIMACORD

Practically any electrode geometry in primacord will function provided that sufficient electric field for electron collection is maintained and provided that the electrodes are located in the plane of the detonation wave front. This last limitation is made because the interaction zone in the wave front is finite and the distribution of ionization therefore finite. To date the most satisfactory electrode system consists of a pair of pins stuck through the primacord in a plane perpendicular to its axis (i.e., perpendicular to the direction of propagation of the wave). With 450 volts between electrodes, a pin separation of 1 to 2 mm is sufficient to insure electron collection. Higher fields than this may involve the hazard of electrical initiation of the H.E.

ELECTRODE GEOMETRY IN SOLID H.E.

For use in solid H.E. the same spacing is used but the pins are clamped in lucite holders. The pin points may be inserted 1/16" into the H.E. or in some instances may be laid on the surface of the explosive.

Where these methods are not feasible the pins have been placed with their points in contact with the H.E. and the space between them has been filled with a plastic H.E.

UNCLASSIFIED

UNCLASSIFIED

DECLASSIFIED

-5-

UNCLASSIFIED

PRECAUTIONS IN SETUP

It has been demonstrated that the shock wave in air or other gas may provide sufficient ionization to provide a substantial pulse. To avoid spurious results it is necessary to arrange the setup geometry to be such that the detonation wave through the H.E. arrives at the pins before any shock waves wherever these originate in the system.

ELECTRONIC METHOD

For general purpose work the electronic equipment usually comprises a primacord pulse generator, a delayable fast-sweep circuit, 5" high-voltage CRO, a timing-mark generator, and mixer circuits. The function of these circuits is briefly described in the following paragraphs; a more complete discussion from the electronic standpoint is given later.

The primacord pulse generator produces a positive pulse from primacord or other H.E. with which to trip the timing circuits, e.g., sweep circuit, timing-mark generator, etc. Moreover, it is intended to prevent more than one tripping signal's being produced because of accidental contacts of the wires leading to the pins (or the pins themselves) after the detonation wave has passed and the wires are struck by the H.E. blast. Without this precaution multiple traces may appear on the CRO confusing the record. The pulse rises to 100 volts in less than 0.1 μ sec and decays exponentially with a 1/e value of about 5 μ secs. It may be used just as a convenient sweep-trip pulse but is more often used as a "time zero" or datum with respect to which time measurements are made.

The delayable sweep circuit provides linear sweeps of from 5 to 100 μ secs duration, together with an intensifying square wave for the CRO. A linear, continuously variable delay circuit is provided which enables the sweep to be started at

DECLASSIFIED

SECRET

UNCLASSIFIED

-6-

any chosen time up to 200 μ secs after the initiating signal. This provision makes it possible to achieve measurements to an accuracy of better than $\pm 0.1 \mu$ secs in 200 μ secs by reason of the expanded time scale at the point where the measurement is made.

The push-pull sweep output from this unit is used to drive a 5CP5 or 5CP11 cathode-ray tube operating with -2.5kv gun voltage and +4kv post accelerator voltage. The tube beam is normally biased completely off and the 70-volt intensifier signal is arranged to turn the beam on for the duration of the forward sweep or observation period only.

Under these conditions single-sweep photography can be accomplished with writing speeds in excess of 2.5 μ secs per inch. A 35-mm camera with aperture f 1.2 using Agfa Fluorapid Blue gives satisfactory results. More recently a standard form of camera has been designed by Group G-11.

The 2- μ sec-marker generator is the "clock" of the system. It accepts a positive pulse derived from the primacord pulse generator (PCPG) from the sweep circuit and proceeds thereafter to generate a series of timing pips spaced exactly 2 μ secs apart for a period of 200 μ secs. These pips are some 70 volts high, roughly triangular in shape with width about 0.1 μ sec at base, and are applied on one of the signal plates of the CRO.

Signals from the mixer circuits, of which a variety are available, are injected on the other signal plate. The interval between any pair of signals may be obtained by interpolating between the timing marks. Or, as is more usually the case, since the position of each of the pips with respect to the PCPG pulse as $t=0$ is known, interpolation gives the time at which any other signal occurs with respect to this pulse.

SECRET

UNCLASSIFIED

UNCLASSIFIED

SECRET

UNCLASSIFIED

SECRET

The block diagram and circuit functions given in Fig. 1 makes clear the operation of the system. In the block diagram the sweep chassis is shown broken into the three component units: - trigger generator, delay circuit, and sweep circuit proper. In normal operation the trigger pulse (A) from the PCPG is fed to the trigger generator in the sweep chassis and is here shaped (B) and fed at low impedance to the delay circuit and marker generator. The marker generator then puts out timing pips (C) of known time relation to the PCPG pulse (A) and the delay unit generates a trigger (D) at a preselected later time which trips the sweep circuit, intensifies the spot on the CRO (waveform E) and produces the positive and negative saw teeth which comprise the push-pull sweep (F). The delay circuit may also be by-passed to provide sweeps which start $0.5 \mu\text{secs}$ after the initiating trigger (A). Thus the present equipment makes it possible to observe phenomena occurring in any interval of 5 to 100 μsecs starting at any time from 0 to 200 μsecs after the $t = 0$ pulse. Since the usable part of the sweep is only $4''$ long it follows that the best resolution is obtained with the fastest sweep and for many applications a sweep speed corresponding to 1 μsec per inch is favored which makes measurements to 0.1 μsec or better possible in the period 0 to 200 μsecs after $t = 0$.

DESCRIPTION OF MEASUREMENTS

(a) Velocity of Detonation Wave in H₂O

Where long time intervals (say 50 to 250 μsecs) have to be measured with high accuracy, two pairs of pins are inserted in the H₂O a known distance apart. The first pair of pins starts the delay circuits, etc. (through the PCPG) and the second pin provides a signal (through a mixer circuit) which is presented on the delayed scope trace. Interpolation between the ~~time markers then yields the~~

SECRET

SECRET

UNCLASSIFIED

UNCLASSIFIED

UNCLASSIFIED

time at which this second pulse occurs relative to the first (see Fig. 2a). Time labels may be attached to the timing pips appearing on the delayed sweep in either of two ways. The first consists in running the sweep delay out slowly from minimum and counting the pips which disappear off the screen to the left. Thus, when the 10th pip moves off the screen the next pip will be the $(2 \times 11) = 22 \mu\text{sec}$ pip. Or provision is made for presenting the delayed trigger (waveform) on a non-delayed long sweep and running the delay out until the trigger takes up the position at which the sweep is required to start. Thus, if the delayed trigger is located before the 40th pip (80 μsec) on the instantaneous or non-delayed sweep, then when the sweep is switched to the "delay" position the first pip on the trace will be the 40th or 80- μsec pip. The sweep speed can then be adjusted to suit the requirement. Alternatively measurements over small time intervals with high accuracy or long intervals with reduced accuracy can be made by starting the sweep from one pair of pins (through PCPG) and locating the signals from two further pairs of pins on the CRO trace and measuring the time interval between these last two signals (see Fig. 2b).

It will be seen that these two methods differ in that the first makes use of the fact that the time scale is calibrated with respect to the primacord pulse as $t = 0$ whereas in the second the time relation of the pips with respect to $t = 0$ is not required.

(b) Measurement of Transit Time Through H₂O Lens

Measurement of the transit time through an explosive lens is accomplished in a similar fashion. The sweep is usually initiated by putting pins into the side of the booster with the detonator at the apex of the lens; the arrival of the detonation wave at the face of the lens is recorded by placing a pair of pins in

UNCLASSIFIED

UNCLASSIFIED

U. S. G. O.
S. P. 100

UNCLASSIFIED

contact with the surface of the H.E. (See Fig. 2c).

In plane H.E. lenses a problem arose requiring the measurement of velocity as a function of position in the lens. A system of electrodes (pins) was positioned in the H.E. (Fig. 2d) with known geometry and the signals from each set of electrodes presented through a mixer circuit, on a single sweep. Since an observation period of at least 100 μ secs was required, a single sweep 4" long gave poor resolution (25 μ secs per inch) with much reduced timing accuracy. To obtain good time resolution under the conditions of this experiment, a multiple sweep was required. This was similar to a television raster giving 20 lines each of 5 μ secs duration, i.e., an observing of 100 μ secs with a resolution of approximately 1" per μ sec.

(c) Simultaneity Measurements on H.E.

A special set of problems arose as a result of the demand for electric detonators, 32 or more of which were to be fired together simultaneously with an accuracy as much better than $\pm 1/2$ μ sec as could be achieved.

As an example, consider the use of a number of primacords of equal length as in Fig. 3a which are to be detonated simultaneously by a system of electric detonators. Suppose that at equal distances along each primacord from the detonator a pair of electrodes (pins) are inserted in the cord. Then, if the detonation wave velocity is constant and the same for all primacords and if the electric detonators initiate all primacords simultaneously, the waves on the primacord will arrive at all electrodes simultaneously. By using short lengths of primacord cut from the same reel, the first assumption (constant and equal velocity from primacord to primacord) can be fulfilled and hence a study of the time of arrival of the waves at such a ~~system of electrodes~~ yields information about

U. S. G. O.
S. P. 100

UNCLASSIFIED

SECRET
 10-

UNCLASSIFIED

the simultaneity of initiation which ~~can be achieved~~ by electric detonators.

A variety of mixer circuits have been designed but they fall into three general classes. The first is the step-wave type in which a small voltage step is produced each time a detonation wave passes between a pair of electrodes. Thus, Fig. 3b shows the type of pattern which results when signals arrive one after the other at equal intervals. Ideally, if the signals all arrive simultaneously they would add to form a single large amplitude step wave (Fig. 3e).

The circuit of Fig. 4 approaches this result but owing to the fact that each voltage step must be 10 volts or more to be readily visible, 32 simultaneous signals requires 320 volts to be developed at the scope. As the mixer circuit must be located near the H.E. and at some distance from the recording equipment the signals are usually fed over coaxial cable of characteristic impedance lying between 50 to 200 ohms. To produce such a voltage across correctly terminated cables is difficult.

If, however, the cable is not properly terminated then a large fast voltage wave front applied at the sending end of the system results in shock excitation of the cable and oscillations appear on top of the step wave making it difficult to see any later signal which appears in this hash.

This limitation led to the second category of circuit in which the cable is properly terminated and the low input resistance is used, in conjunction with a small capacity, to obtain a strongly differentiated signal. The circuits are usually arranged to provide a 15-volt pulse at the scope. The signal has the shape shown in Fig. 3d. The whole signal can be made to be over in 0.2 microseconds, so that high resolution is possible. Faster signals than this are prohibited by the difficulty of photographing the trace but could well be used with a CRO of higher

~~SECRET~~

UNCLASSIFIED

SECRET

SECRET

writing speed. A number of simultaneous signals then add to produce a larger signal (Fig. 3e) and "stepping" of the wave front makes it possible to determine lack of simultaneity (Fig. 3f).

However, with this circuit too, when a large number of signals occur simultaneously and are followed by a single signal, it is often difficult to observe the late signal. This difficulty became apparent when the detonator development reached the point where spreads of only 0.1 μ sec were observed in 32 detonators.

To overcome this trouble a third circuit type - the Plus-Minus Mixer - was developed. In this circuit 16 signals are made positive and 16 negative. If the system is completely simultaneous they cancel and no output results. If, however, one signal is later than the majority it is plainly visible.

It is difficult from any of these results to obtain the distribution in time at which the detonators fire and for this information the rotating-prism-camera method has the advantage. A more complete description of these circuits is appended later.

(d) Further Applications of the Technique

Many further applications become apparent but the present system has been used to examine the reliability of H.E. branching devices, transmission of detonation waves from one H.E. to another via metal or air gap, Munro jets, detonation wave patterns in H.E. lens systems, consistency of velocity in primacord, etc.

It has been demonstrated, also, that the ionization in the high-pressure region of a shock wave front in a gas is sufficient to actuate the circuits.

DESCRIPTION OF THE ELECTRONIC CIRCUITS

Primacord Pulse Generator; Fig. 5

The function of this circuit is to produce a steep positive voltage

SECRET
 - 12 -

signal from primacord with which to trip other circuits, e.g. timing circuits, sweep circuits, etc. Moreover, it is intended to prevent more than one tripping signal being produced because of accidental contacts of the wires leading to the primacord when these are struck by the H.E. blast. Without this precaution multiple traces appear on the CRO confusing the record. The circuit functions as follows: A 0.01-mfd condenser is charged to 400 v through the 10k ohm resistor in the plate of the 2050 which is biased off.

A low-resistance charging circuit is required since the DC resistance measured between the electrodes in the primacord may, on damp days, fall as low as 25k ohms.

By means of a double Amphenol cable connector, the high-voltage side of the condenser is connected to one of the electrodes in the primacord and the other is connected to ground through 5k ohm. The detonation wave passing through the electrodes in the primacord under these conditions produces a resistance between them which instantaneously approaches zero. Thus, a voltage signal considerably greater than 200 v is developed across the 5k ohm and drives the two cathode followers into grid current. Cathode conduction in the 6SN7 starts when the signal wave front reaches an amplitude of 90 volts and the positive cathode signal is fed back to fire the 2050 Thyatron.

After a slight initiation delay the Thyatron discharges the 0.01-mfd condenser through 500 ohms and remains conducting to prevent recharge of the condenser. Further short circuits of the pins or connecting wires due to accidents in the post explosion period cause no significant voltage pulses across the 5k ohms and hence, no further tripping pulses. The positive signal developed is put out at low impedance through the 6AG7 cathode follower into cables leading to other apparatus. The output signal rises to 100 v in a tenth of a μ sec and decays ex-

SECRET
SECRET



ponentially with a $1/e$ value of about 5 μ secs.

A remote switch in the anode circuit of the 2050 allows voltage to be applied to the primacord electrodes after the operator has moved a safe distance from the H_oE. A remote 0-to-1 milliammeter connected to pin 1 of J3 allows the operator to check the voltage on the 0.01-mfd condenser. In this way short circuits or low resistances across the primacord electrodes can be observed remotely. For test purposes a normally open microswitch is provided which, when closed, short circuits the primacord electrodes to simulate the primacord pulse. A normally open relay which may be operated through pins 2 and 3 of J3 enables a remote control test of the system to be made. Owing to the heavy current drain through the 2050 after it has fired, it is necessary to open the anode circuit after firing to extinguish the discharge.

This pulse has been used as a "time zero" or datum with respect to which time measurements are made.

MIXER CIRCUITS

The circuits of Figs. 6, 7, 8, 9, and 10 were designed for various applications. Since the pulse rise times involved are of the order 10^{-7} secs, or less, vacuum-tube amplifiers have been avoided and the pulses have been generated at a level large enough for convenient viewing on a high-speed oscillograph. Fig. 6 shows a circuit designed to mix together the signals into a common capacity C_1 . Each of the condensers C_2, C_3, \dots, C_{17} are charged to 450 v through a high impedance and are connected to the various pairs of pins. Whenever a detonation wave passes between a pair of pins its capacity spills charge into the common capacity C_1 . The magnitude of the voltage signal thus obtained can be adjusted by choosing the relative values of $C_2 \dots C_{17}$ and C_1 . The voltage signal is transmitted down coaxial

SECRET
SECRET



SECRET
 CONFIDENTIAL

cable which is terminated in its characteristic impedance at the CRO to prevent reflections (in this case 200-ohm cable is employed). The small resistance R_1 is included to damp the circuit critically. A single pulse rises in less than 0.1 μ sec and has an exponential tail of time constant depending upon the value of C_1 and its shunting resistance. The output voltage across C_1 is not a linear function of the number of pins P_1 --- P_{16} firing together since the condensers C_2 --- C_{17} are put in parallel with C_1 after the pin switches P_1 --- P_{16} close, but linearity can be approached by making the condensers C_2 --- C_{17} as small compared with C_1 as is compatible with pulse size.

Each of the condensers C_2 --- C_{17} is charged through a high resistance, the time constant being long enough that further mechanical contacts of pins or wiring cannot produce significant pulses during the viewing period. Alternatively an electron tube clamp circuit may be used to prevent recharge of the condensers once they have been discharged.

Fig. 7. In this circuit, mixing is effected into a common resistance. This resistance when the switch S is open, is the input impedance to the 50-ohm cable which, when the cable is correctly terminated at the scope, is resistive and equal to 50 ohms.

When S is closed, the common resistance is reduced since R_{17} is switched in parallel with the 50-ohm cable input resistance. With S open, the voltage developed at the scope, when the detonation wave passes between a pair of electrodes P_1 , is 90 volts high, rises in less than 0.1 μ sec, and has an exponential tail determined by the time constant $C_1(R_1 + 50)$ secs. This large pulse is used whenever the circuit is employed for velocity measurements. With S closed, R_{17} is usually chosen to give a 15-volt pulse at the scope and the circuit in this condition is suitable for simultaneity measurements. Again, the voltage developed across the

SECRET
 CONFIDENTIAL

SECRET
SECRET

mixing resistor is not a linear function of the number of pins P_1 --- P_{16} switching simultaneously since the current from any condenser, say C_1 is determined by the potential difference across R_1 . Thus, the pulse size gets smaller the greater the voltage across the mixing resistor.

Each of the condensers C_1 --- C_{16} is charged through a high-enough resistance to prevent pulses of significant size from being produced during the observation period because of mechanical shorts of the pins in the post-explosion period. An electron tube clamp circuit may be used to prevent recharge of the condensers once they have been discharged.

Very fast pulses have been obtained by reducing the condensers C_1 --- C_{16} to values as low as 400 mmfd. The circuit has also been used with as many as 64 signals mixed together.

Fig. 8 shows a rearrangement of the above circuit for use where one pin of each pair (or one electrode of a mechanical switch) is required to be at ground potential. The function of the circuit is essentially the same.

Fig. 9. Because of the non-linearity of the above circuits a circuit was devised to maintain the mean potential difference across the mixing resistance at zero.

This is achieved by charging one-half of the condensers, e.g., C_1 , positively to 450 volts and the other half e.g., C_2 , negatively to -450 volts. The currents from these condensers flow into a common mixing resistor (50 ohms when the output cable is correctly terminated and S is open; 25 ohms when S is closed and cable is correctly terminated). When detonation waves pass through the electrodes P_1 --- P_2 the currents are then alternately positive and negative and sum is zero.

Thus, if all switches closed simultaneously there would be no e.m.f. across the output, but in the general case the switches close one after another and as many positive voltage steps result as negative steps and the mean potential is thus ground. With S open the single signal size is 90 volts; with S closed the signal size is 45 volts.

U. S. G. O.
S. I. M. S.

-16-

Since, for ideal operation, each signal should be a step (or unit function) wave, the time constants like $C_1 R_1$ are made long compared with the time spreads to be measured. However, when shots were made with pins in primacord a fast-rising pulse (rise less than $0.1 \mu\text{sec}$ with a flat top about $0.3 \mu\text{sec}$ followed by a tail of roughly exponential shape of total duration $0.3 \mu\text{sec}$) was obtained irrespective of the time constant $C_1 R_1$ (provided this was greater than $5 \mu\text{secs}$). This may be interpreted as due to the fact that the ionization between the electrodes is finite and once all electrons have been sucked out of the volume the current ceases since the positive-ion space charge drifts too slowly to contribute to the current before the system blows apart.

The circuit has been used also where it has been necessary to identify the signals associated with certain pairs of pins. This is done by making three resistors like R_1 in the positive side different so that three different-sized positive pulses are obtained and three resistors like R_2 in the negative side different so that three different-sized negative pulses are obtained. In this fashion six identifiable signals are obtained and time labels may be attached to the instants at which the detonation waves passed between the various pairs of pins.

To prevent additional pulses due to mechanical contact of the pins or their leads after the explosion the charging resistors for the condensers C_1 , C_2 etc. are made large so that they cannot acquire sufficient charge to give significant pulses during the period of observation. Electronic clamp circuits to prevent recharge of these condensers after the initial charge is removed may also be used.

U. S. G. O.
S. I. M. S.

SECRET
 CONFIDENTIAL

-17-

DELAYABLE SWEEP CIRCUIT - Fig. 11

The first stage VI is a trigger generator. By means of the ganged three-position switches S1 and S2 the circuit can perform any of three functions;

Position 1 - Operating Position: a positive pulse put in through either of the sockets marked "primacord in" fires the 2050. A pulse of 100 volts' amplitude rising in $0.1 \mu\text{sec}$ is necessary to fire the tube with a delay less than $0.1 \mu\text{sec}$. Slower pulses will lead to greater delays in starting. On firing, a steep positive pulse is produced at the cathode and is cathode followed out through V_2 to provide a trigger for other circuits.

After firing, V_1 continues to conduct through the 50kohm anode load until the anode switch S6 is opened. Before firing, check that S6 has been closed by observing the reading on the 0-to-1 milliammeter. After firing, the meter indication will fall almost to zero and S6 should be opened immediately to extinguish the discharge.

Position 2 - 60-cycle Repetitive Test: in this position V_1 is triggered from the 60-cycle AC supply to provide a recurrent trace on the CRO for visual determination of sweep durations, etc. The circuit may be tested using a synchroscope Model P4 by inserting the synchroscope trigger in the jack marked "Test Pulse In" (black panel) and switching S_5 to the appropriate position. After use, switch S_5 back or the 60-cycle repetition rate will not function.

Position 3 - Test and Calibrate Position: in this position the circuit is triggered manually by means of the microswitch enabling a time calibrating trace to be put on the scope and photographed on the same film as the signal. The switching sequence for S_6 given above is necessary in this position. Normally this position is used for test purposes only as the timing marks are photographed simultaneously with the signal.

SECRET

-18-

The remainder of the circuit functions as follows; the second half of V_2 inverts the positive trigger from the first half and drives a gate univibrator V_3 whose gate width may be chosen to be 100 μ secs or 200 μ secs. A screwdriver bias adjustment for the second half of V_3 must be set to maintain this tube normally off or the system will "run free". It will also be found that the bias value will affect the gate width and this provides a convenient fine adjustment.

The negative gate generated at $P_5 V_3$ is used to cut off the triod clamp tube (1st half V_5). The sawtooth wave form developed at $P_2 V_5$ is made linear by the "bootstrap" method of maintaining the charging current through the 250kohm anode load essentially constant by the feed-back arrangement involving the 2nd half V_5 and the 1st half of the diode V_4 . Because the cathode follower (2nd half V_5) does not have unity gain the sawtooth at its grid is rather more linear than at its cathode and this wave is fed into a diode (2nd half V_4) whose cathode can be biased between 0 and 250 v.

Conduction through this diode does not start until the anode becomes positive with respect to the cathode and the time at which a signal is developed across the 25kohm cathode load of V_4 will depend upon the bias value chosen on the potentiometer marked "COARSE DELAY". A vernier delay adjustment is also included to make adjustments within a 1 μ sec range. The delay controls are linear and read in microseconds with a reset accuracy of the order of $\pm 0.5 \mu$ secs.

The positive pulse arising at the cathode of V_4 can thus be delayed at will with respect to $t=0$ and is used to drive V_7 into grid current from cutoff. The negative signal developed at the anode of V_7 is inverted through the pulse transformer 145EW whose secondary is connected as a "bootstrap" or inverted amplifier. The diode V_6 is connected across the primary of the pulse transformer to

SECRET

SECRET
TOP SECRET

-19-

prevent a positive overswing. The signal at the cathode of the bootstrap amplifier rises in 1 μ sec to 250 volts but is not provided at low impedance as in a cathode follower. It is, therefore, put out through the second half V_9 driven as a cathode follower to provide a delayed trigger pulse. This is the pulse which is thrown on to a non-delayed sweep for the setting of an appropriate delay in operation and it may also be used for triggering other circuits in known time relation to $t=0$. The same signal is fed to the grid of the 2nd half of V_8 which is connected as a cathode follower with one winding of a 145EW pulse transformer in its cathode circuit. The positive pulse developed across this winding is used to drive a blocking oscillator (1st half V_9) which develops a fast positive pulse across its cathode load. This pulse is used to start the sweep circuit when a delayed sweep is required.

A two-position selector switch S_3 makes it possible to accept either the delayed trigger or the instantaneous trigger from the cathode of V_2 (p3) to provide sweeps with variable delay or zero delay. The 1st half of V_{10} is used to invert the signal and provide a negative trigger to the univibrator V_{11} , V_{12} .

The gate width of this univibrator can be varied by the four-position switch S_5 which is ganged to S_4 in the sweep generator. Intensifier gates and corresponding sawtooths of duration 5, 10, 20 and 100 μ secs are provided. The univibrator is sensitive to fluctuations of the +300 and -150 v power supplies since pentodes are used. For this reason the +300 and -150 volt DC supplies are electronically regulated. A screwdriver bias adjustment is provided for correct biasing of V_4 and the circuit is sensitive to this adjustment.

The positive gate at the plate of V_{11} is cathode followed out through the second half of V_{10} to provide an intensifying gate to the CRO. The negative

SECRET
TOP SECRET

SECRET

-20-

square wave generated at the anode of V_{12} is used to turn off the clamp tube V_{14} and generate the sweep. A pentode rather than a triode is used in this position to prevent a negative signal's being transmitted via the anode-grid capacity. The rise of anode voltage at the anode of V_{14} is made to be very nearly linear by a feed-back action through the cathode follower 1st half V_{15} and the diode V_{13} . If the cathode follower had unity gain its cathode would rise at the same rate as the anode of V_{14} , and the 0.1 mfd condenser drives the cathode of V_{13} above its static voltage of +300 at the same rate causing a cessation of current through it. In this fashion the voltage across the anode load of V_{14} is maintained nearly constant and hence the rise of anode voltage of V_{14} is constant. The rate of rise of voltage, and therefore sweep speed, is controlled by the coarse adjustment (selector switch S5) which varies the capacity to be charged and a vernier control (variable 250kohm pot. in plate circuit of V_{14}) which varies the charging current. The first half of V_{15} provides a positive sawtooth to one deflector plate and the second half is connected as an amplifier of unity gain which inverts the sawtooth to provide push-pull deflection. For better linearity particularly with fast sweeps (5 μ secs or less) the output stages would better be pentodes but, as is shown later, this is not the limitation in the present system.

CATHODE-RAY OSCILLOGRAPH: Fig. 12

For high-speed single-sweep photography the P5 or P11 screws and 5" CRO tubes type 5CP5, 5CP11, 5JP5, 5JP11 are preferred. The type J tubes have lower input capacities than the type C tubes. They both function satisfactorily in the present circuit. Conventional power supplies provide -2.5 kv to the electron gun and +4 kv to the post accelerator. Under these conditions a deflector sensitivity

SECRET

SECRET

U. S. G. O.
S. I. P. O.

-21-

of about 100 volts per inch results. The shift controls, vertical and horizontal, are operated from the +300, -150 volt supply provided for the sweep circuit. A signal-selector switch is provided to enable various signals to be presented without changing cables.

In spite of the linearity of the sweep voltages provided by the sweep circuit the photographic records are not linear over their complete length. This is due to two effects, the first of which is the curvature of the face of the scope tube and the second is due to nonuniform magnification over the camera field. These two effects are most serious at the edges of the scope screen and, for this reason, signals to be timed should, as far as possible, be arranged to fall in the center of the scope trace where the linearity of the overall system is best.

2- μ sec MARKER GENERATOR: Fig. 13

The circuit is designed to accept a positive input pulse of 25 volts or more and proceed to generate thereafter a series of pips spaced at 2 μ sec apart for a period of 100 or 200 μ secs. If a standard input pulse is available the position of each one of the timing pips with respect to it can be measured and the circuit provides a time scale for calibrating CRO traces.

In general, timing measurements have to be made with respect to an electrical signal developed from a high explosive by means of the primacord pulse generator (Fig. 15) B-1264, and this signal is regarded as $t=0$.

CIRCUIT OPERATION

The positive input trigger to the buffer tube VT-1 pulls current through the 20k ohms anode load of the second half of VT-2 and thereby triggers the gate MV (or univibrator circuit) comprising VT-2 and a negative square wave of voltage of

U. S. G. O.
S. I. P. O.

SECRET
SECRET

-22-

amplitude about 150 volts is generated at pin 5 VT-2. The duration of this "gate" is determined by the RC value of the capacity between pin 1 and pin 5 of VT-2 and the resistance from pin 1 to B⁺ and also, to a lesser extent, by the static bias voltage at pin 4. If the bias is too small the univibrator may run free and multi-vibrate. This may be corrected by the 100k ohms Screw Driver adjustment located on the top of the chassis. The negative gate at p5 VT-2 is used to cutoff the clamp tube (2nd half VT-1) and allow a Hartley Oscillator VT-3 to commence oscillating. The amplitude of the oscillations across the tank circuit in the cathode of the clamp can be made constant from the moment of unclamping as follows:

In the static condition the clamp tube carried 15 ma and energy is stored in the tank as $1/2 Li^2$. On clamping this energy oscillates back and forth between the capacity and inductance in the tank. With no losses therefore, the peak voltage across the condenser V can be computed from $1/2 CV^2 = 1/2 Li^2$.

If the Hartley were disconnected these oscillations would die out exponentially at a rate determined by the Q of the circuit. On the other hand, if the Hartley has to start oscillation from zero tank energy the oscillations build up exponentially depending upon the Q of the circuit and of amplitude determined by the feedback resistors (R_2) in the cathode. Thus, by adjusting R^2 so that the final amplitude is the same as the initial one the two exponentials cancel each other out and a sine wave of constant amplitude results. To operate at 500 kc (pip spacing of 2 μ secs) the Sickles coil 12789A has been reduced from 1.5 mh to 1 mh in order that the tuning capacity can be kept large compared with interelectrode capacities which are temperature dependent and therefore lead to frequency instability. For the same reason, the screen is bootstrapped to the cathode in VT-3 so that cathode-screen potential is maintained constant and hence the input capacity of the tube

SECRET
SECRET

SECRET
TOP SECRET

-23-

made a minimum. Changing the tube VT-3 then does not upset the frequency calibration. The output from VT-3 is cathode followed through VT-4. A phase inversion is obtained by means of the transformer in the cathode circuit. The trigger tube VT-5 is normally biased off through the transformer secondary. As soon as the gate opens and the oscillator starts up the first half cycle (which is positive) and succeeding positive half cycles drive VT-5 into grid current through the 1k series grid resistor provided to prevent excessive loading. In this way, the tube VT-5 is switched whenever the sine wave crosses the axis with dE/dt a maximum and positive. VT-5 drives the blocking oscillator VT-6 by pulling current through the anode load of VT-6 and hence driving its grid positive producing regeneration. The anode current plus grid current pulses flowing through the cathode load produce a voltage output of amplitude about 75 volts roughly triangular in shape and with a width of 0.1 μ secs at the base.

Screwdriver controls for the grid time constant and grid bias of VT-6 are located on top of the chassis. If the grid time constant is too large the circuit may become unstable or frequency divide; if the grid bias is too low the circuit may start to oscillate freely at a frequency determined by the grid time constants.

Voltage regulated power supplies of +300 and -150 volts are built on the chassis and should be checked before R3 and R4 are adjusted to obtain pips at the driver frequency of 500 kc.

FREQUENCY STABILITY OF CIRCUIT

After a warmup period of 20 minutes the oscillator will have reached steady state conditions and under normal ambient temperature conditions the day to day variations are less than 0.1%. Over a period of months the stability is good to 1/2%. The pip spacing for the first one or two cycles may not be exactly

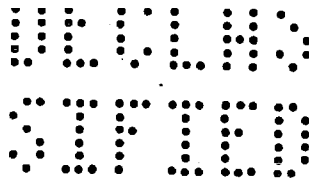

-24-



2.0 μ secs owing to transient effects but the shift is normally less than 0.1 μ sec. In the same way the spacing of the last two or three pips is affected as the clamp tube comes into operation and shorts the tuned circuit.

CALIBRATION OF PIPS

Where relative time measurements only are required all that is necessary is to tune the oscillator to 500 kc so that the pip spacing is exactly 2 μ secs. This may be done in a variety of ways one of which is to open the grid of (VT-1 2nd half) and bias this tube to -150 volts. The Hartley oscillator then runs free and a Lissajou figure can be formed with a frequency standard (e.g., crystal oscillator at 500 kc) by taking the sine wave generated at the cathode of VT-4.

Where absolute time measurements are required relative to "zero time" (pulse from primacord pulse generator) we have to attach a time label to each of the pips. The calibration is then a little more complicated and can best be effected by means of a circular sweep circuit.

For this purpose a crystal controlled Sickles Calibrator, Model 3, has been modified to operate at 100 kc and provide a sweep traversing the circle in 10 μ secs. A central deflecting electrode on the CRO enables a radial deflection of the sweep to be made and the 100 kc is divided down to provide a trigger signal at 500 cycles so that circuits may be triggered in synchronism with the sweep. To take up the small delay in the sweep circuit trigger generator the Sickles Calibrator trigger is fed through it to the Marker Generator which then develops trains of pips at 500 cycles.

When these pips are injected on the central deflector electrode and the tank circuit of VT-3 is correctly tuned they fall into five sets of pips lying on top of each other on the circular sweep and hence 2 μ secs apart. In this fashion

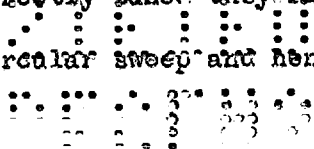

SECRET
SECRET

-25-

tuning can be very accurately accomplished. In order to attach time labels to the pips the delay between the time zero pulse (trigger from Sickles calibrator) to the first, second, third, etc., pip has to be measured. This is achieved by employing an intensifying gate on the circular sweep which brightens the trace for one (or less) revolutions per cycle (i.e., for 10 μ secs every 2000 μ secs). Moreover this gate may be delayed with respect to the trigger pulse up to 300 μ secs by means of a linear delay circuit. Thus, we can observe for 10 μ secs starting at any time within 300 μ secs of the trigger signal. In this way the position in time of each of the pips can be examined separately and read off on the calibrated scale. The absolute time label attached to the pips by this measurement is good to $\pm 0.05 \mu$ sec and the pip frequency can be set to better than one part in a thousand.

POWER SUPPLY: Fig. 14

This unit comprises conventional electronically regulated +300 v and -150 v supplies with an unregulated +425 v being available.

The positive supply is capable of a total output of 200 ma, i.e., the sum of the currents from the 425 v and 300 v supplies must not exceed this figure.

The negative supply is rated at 70 ma maximum output. The positive and negative voltage adjustments are located on the front panel, together with test points.

The help of Messrs. C.R. Linton, Gil Mathis, Sgt. R. Lowry and Sgt. Val Fitch who built and serviced many sets of the equipment described above, and helpful discussion with members of the Electronics Group and the many groups in the H.E. Division who have used the equipment in the field, are gratefully acknowledged.

SECRET
SECRET

BLOCK DIAGRAM

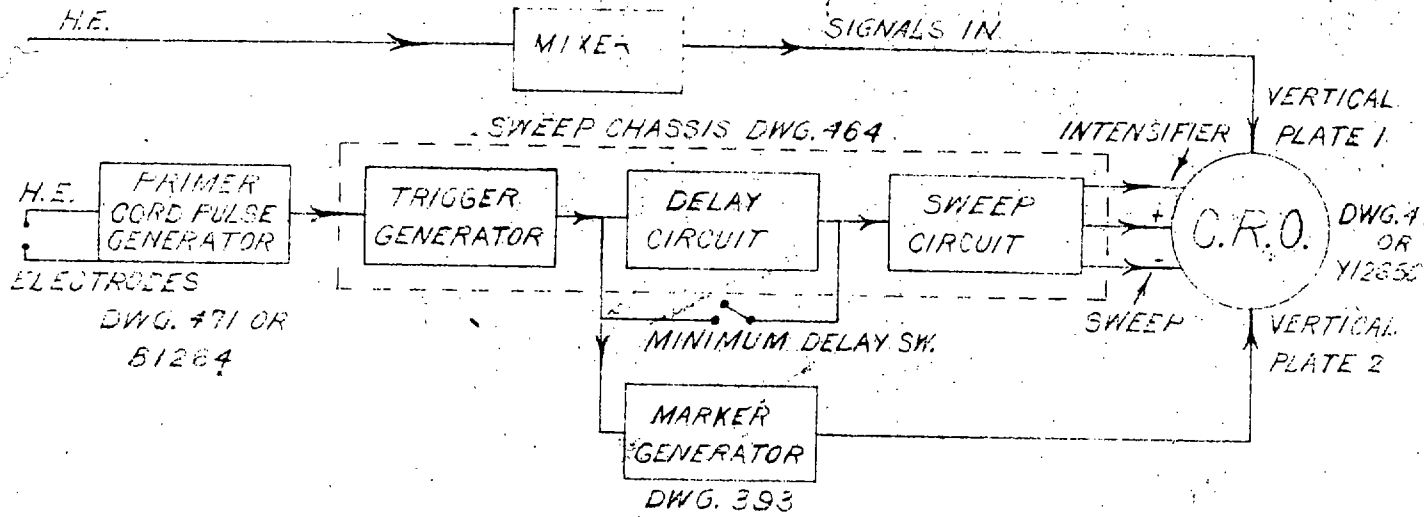

CIRCUIT FUNCTIONS

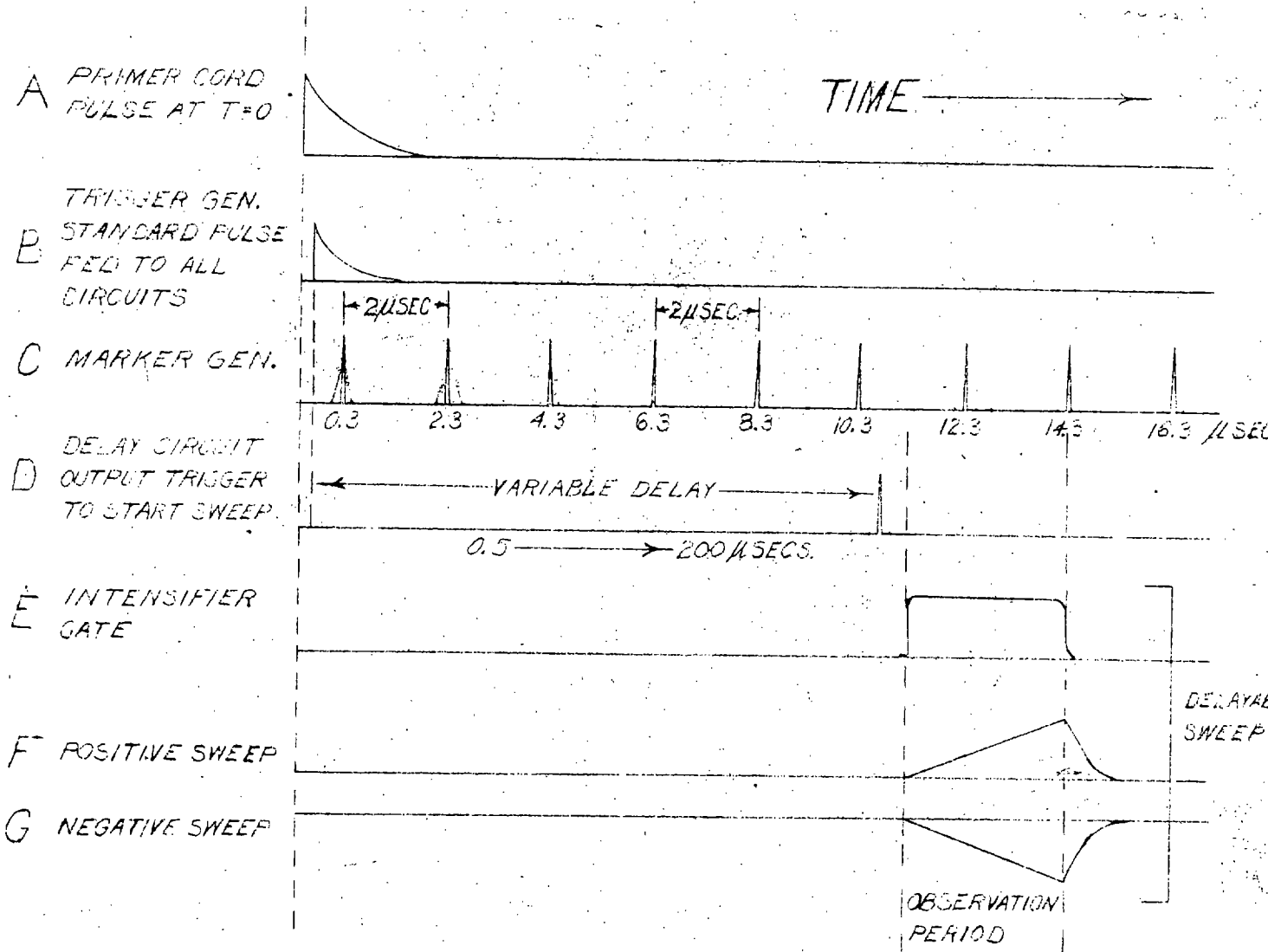

FIG. 1
E.W.T.

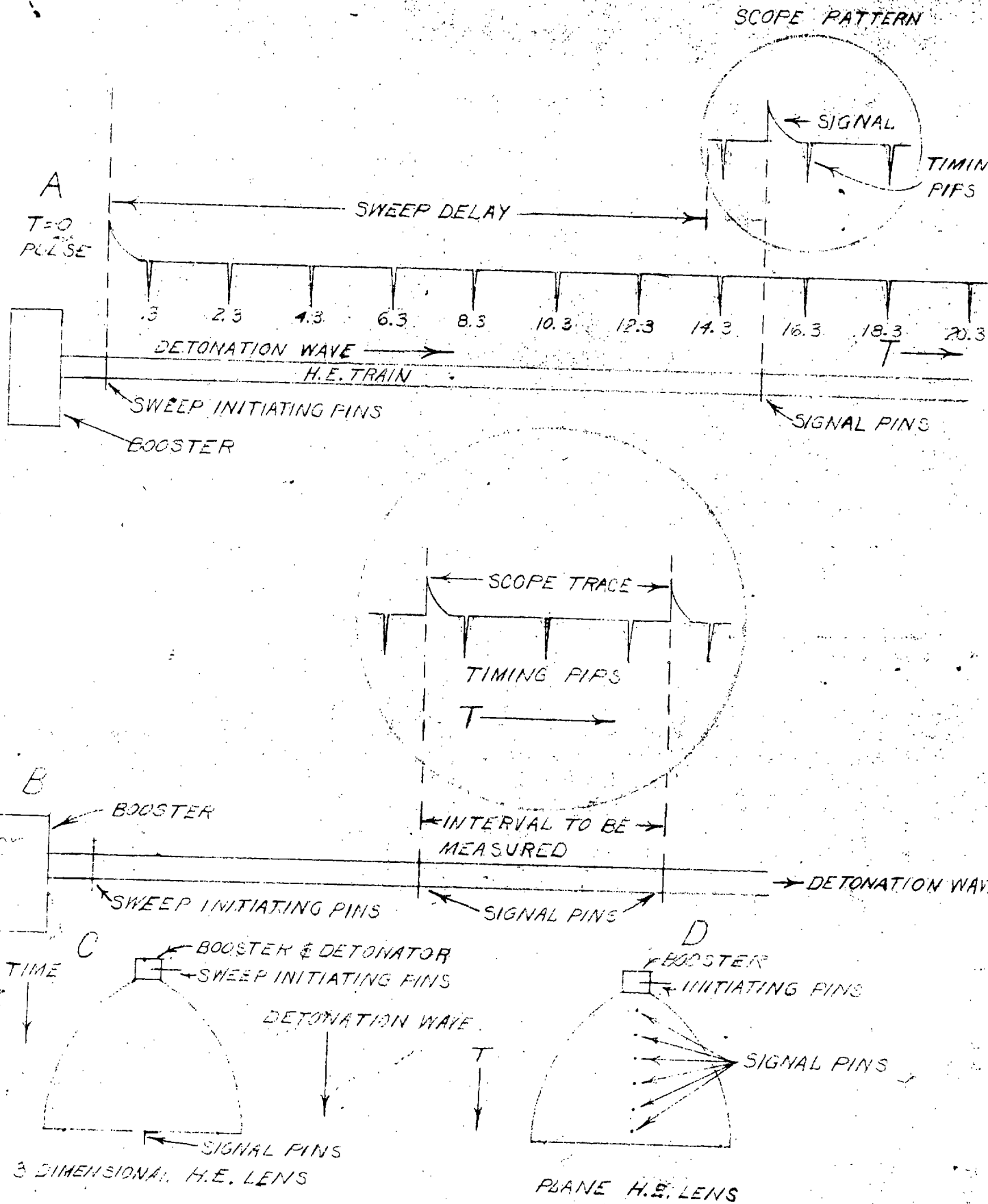

FIG. 2
E.W.T.

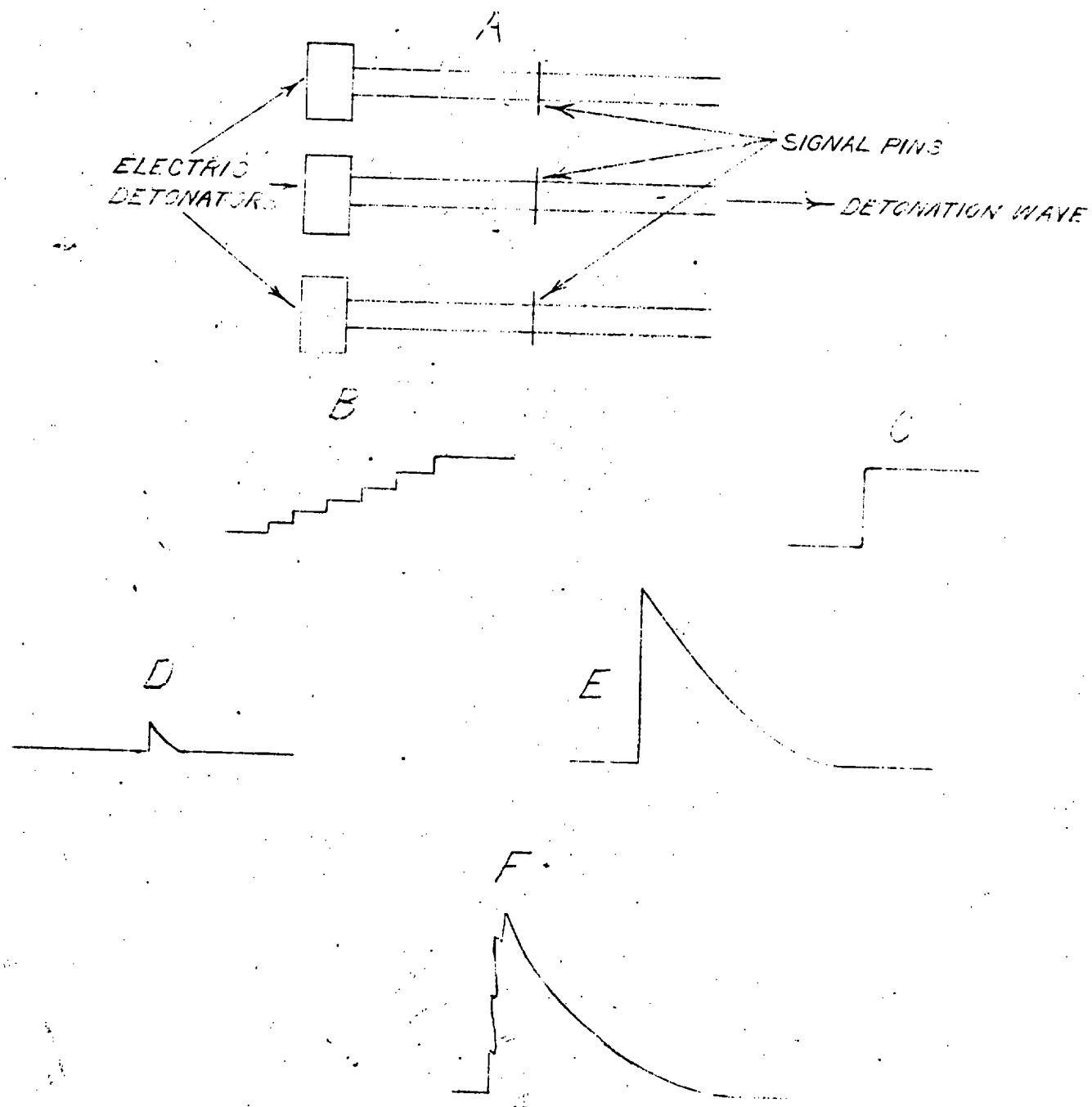

FIG. 3
E.W.T.

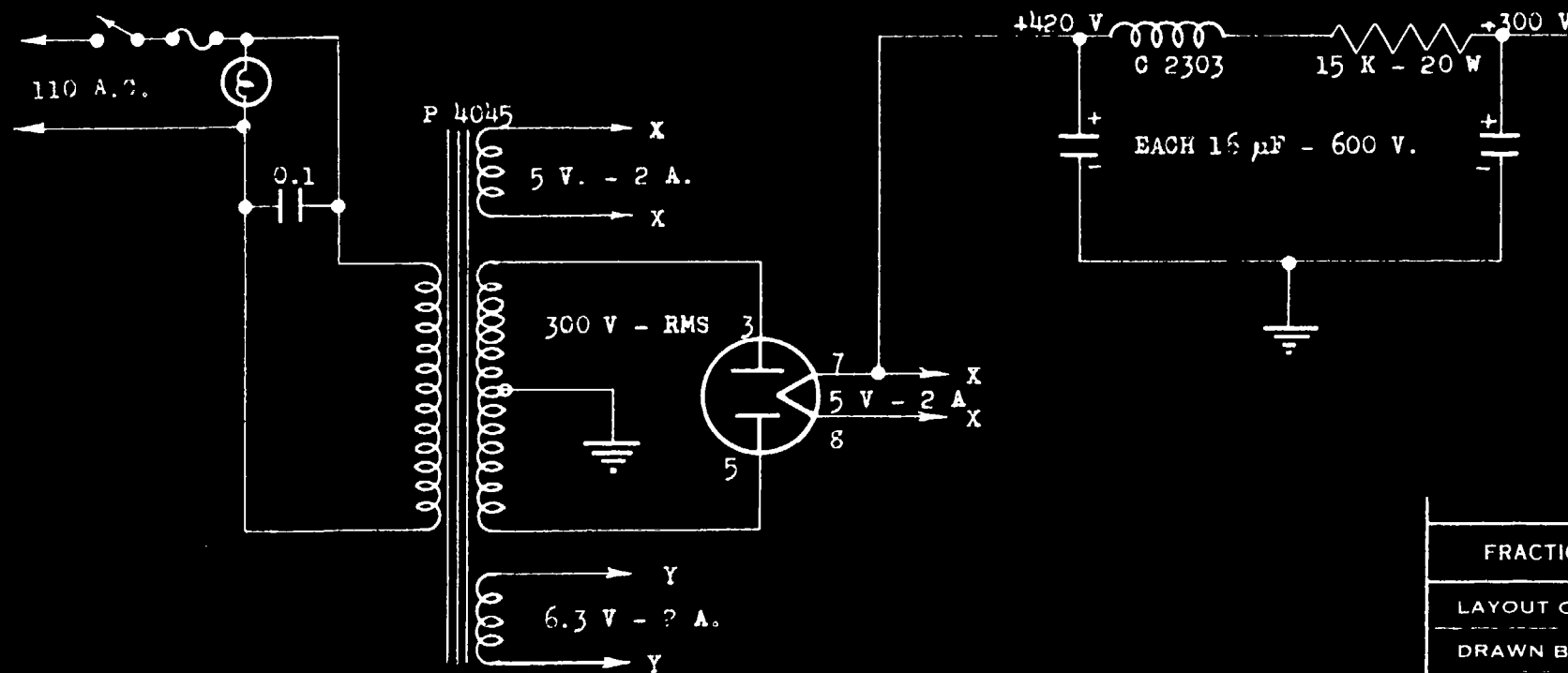
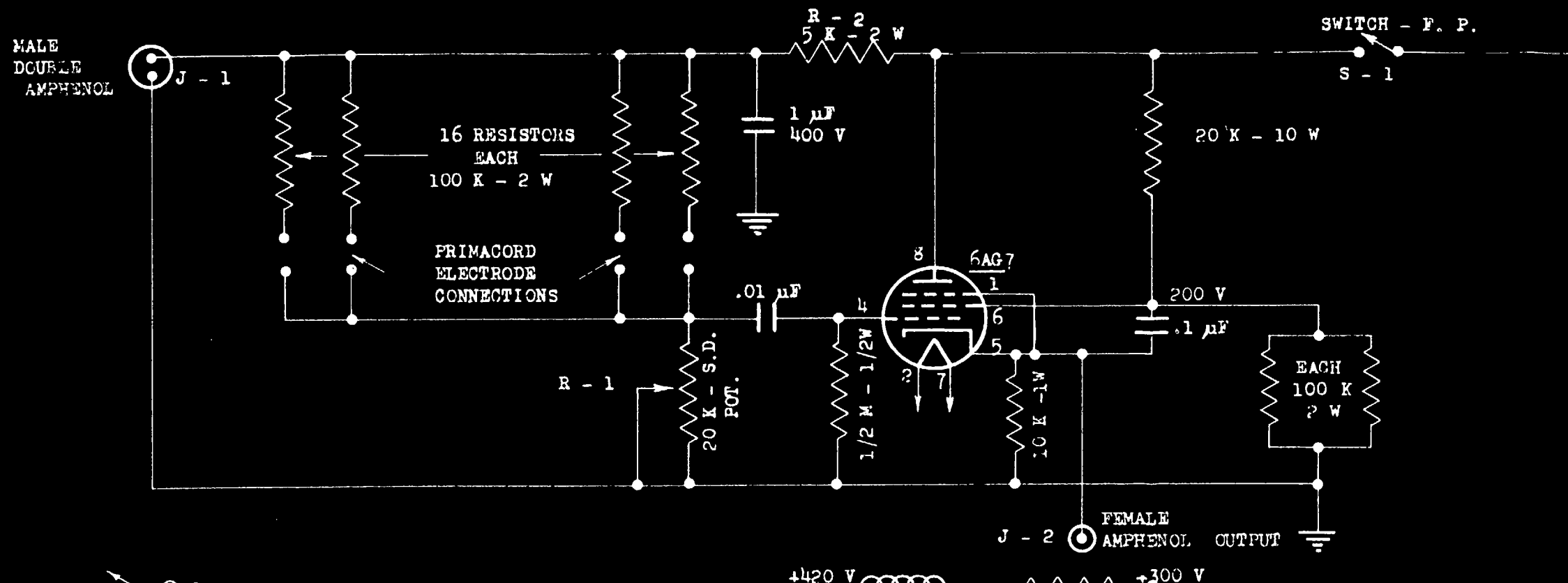

FIG. 4

FRACTIONAL TOLERANCE : .010 EXCEPT AS NOTED		REV	CHANGED ITEM WAS	DATE	BY
LAYOUT OR SKETCH BY E.W.TITTERTON		LET			
DRAWN BY M. H. DIKE		PART NAME			
CHECK BY		PRIMACORD			
GROUP REPR. E.W.T.		MULTI-CHANNEL MIXER			
GR. NO. E-2		SCALE		DRAWING NO.	
CH. ENG.		SHT. - 1		Y - 1341	
APPROVED		1 SHTS.			

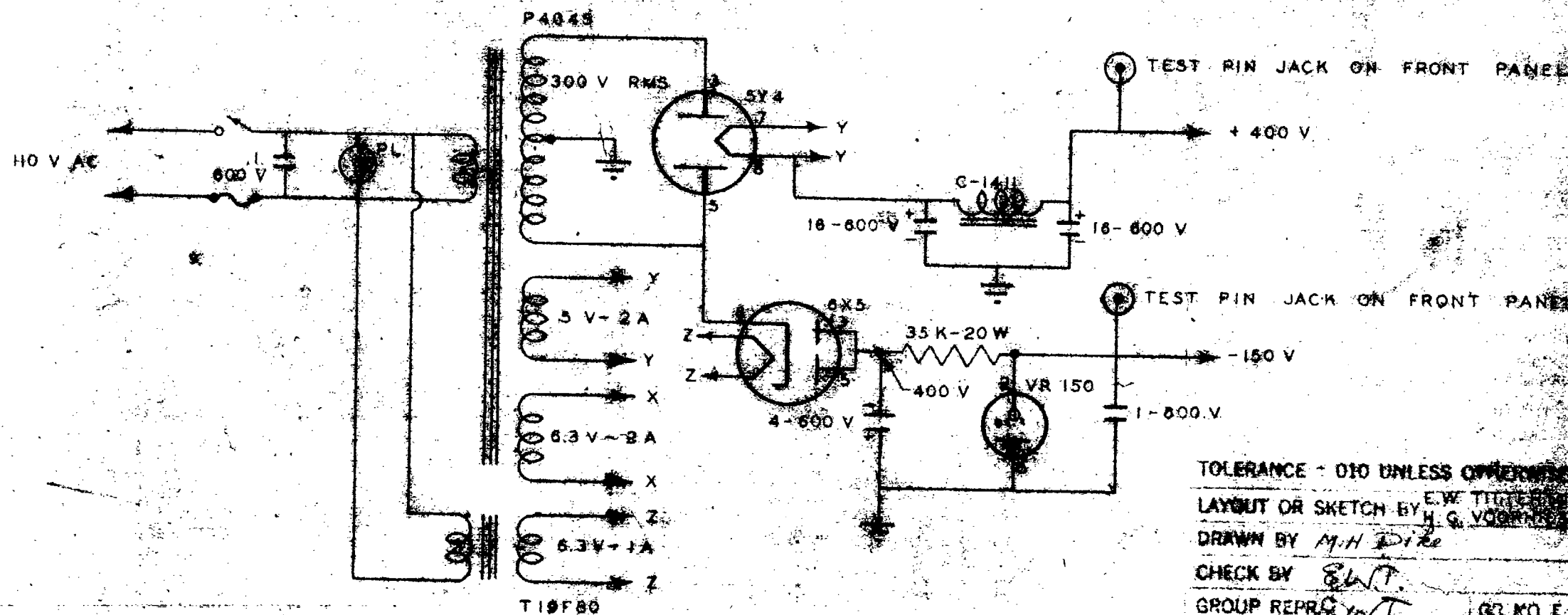
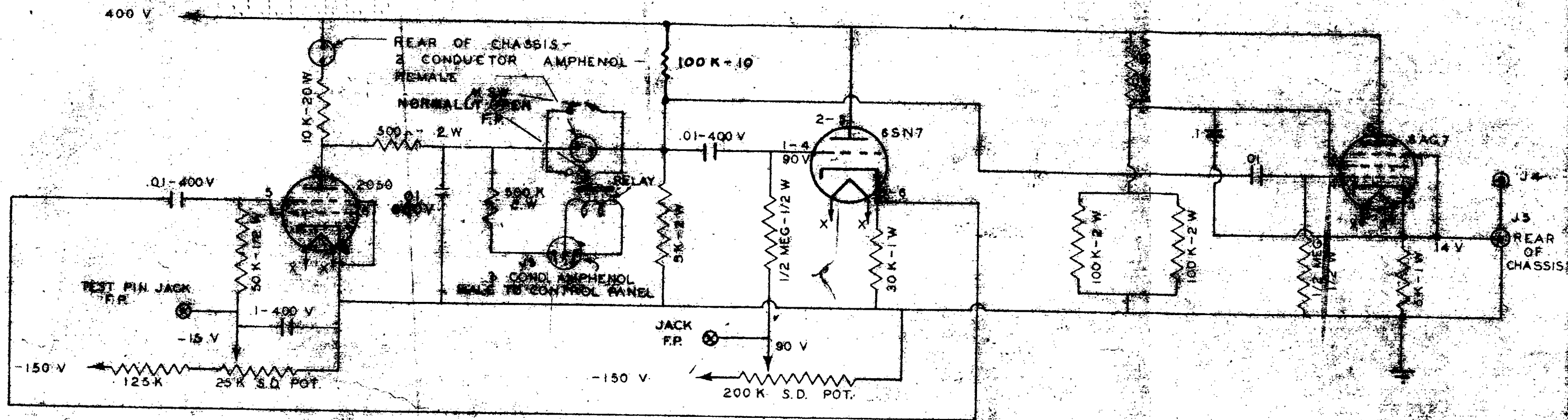

FIG 5

TOLERANCE - 0.10 UNLESS OTHERWISE NOTED

LAYOUT OR SKETCH BY E.W. TITUS

DRAWN BY M.H. DIXON

CHECK BY E.W.T.

GROUP REPRESENTATIVE E.W.T.

CH. ENG. APPROVED

DATE 5/30/44

GR. NO. E-2

REV LET	CHANGED FROM WAS	DATE	BY
	PRIMER		
	PULSE		
	CORD		
	GENERATOR		
SCALE	DRAWING NO.		
SHT. #	B-1264		

Drawing 471

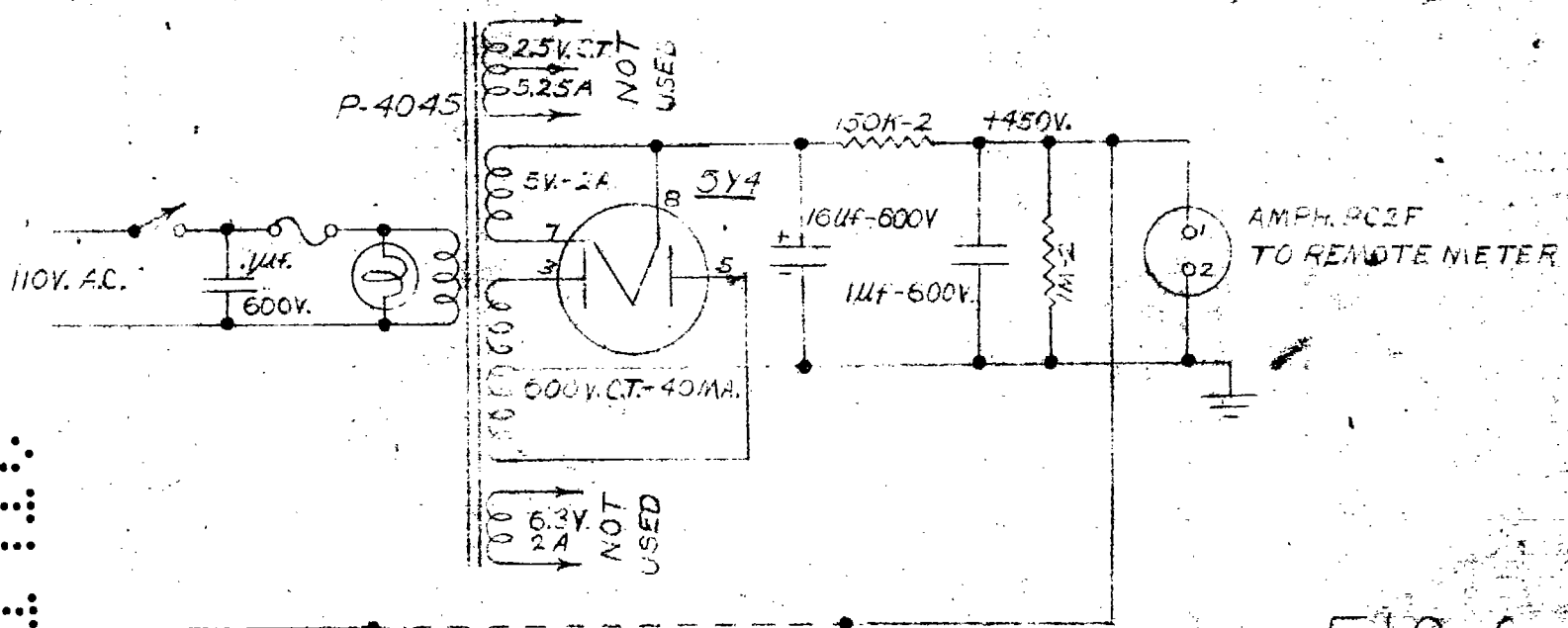
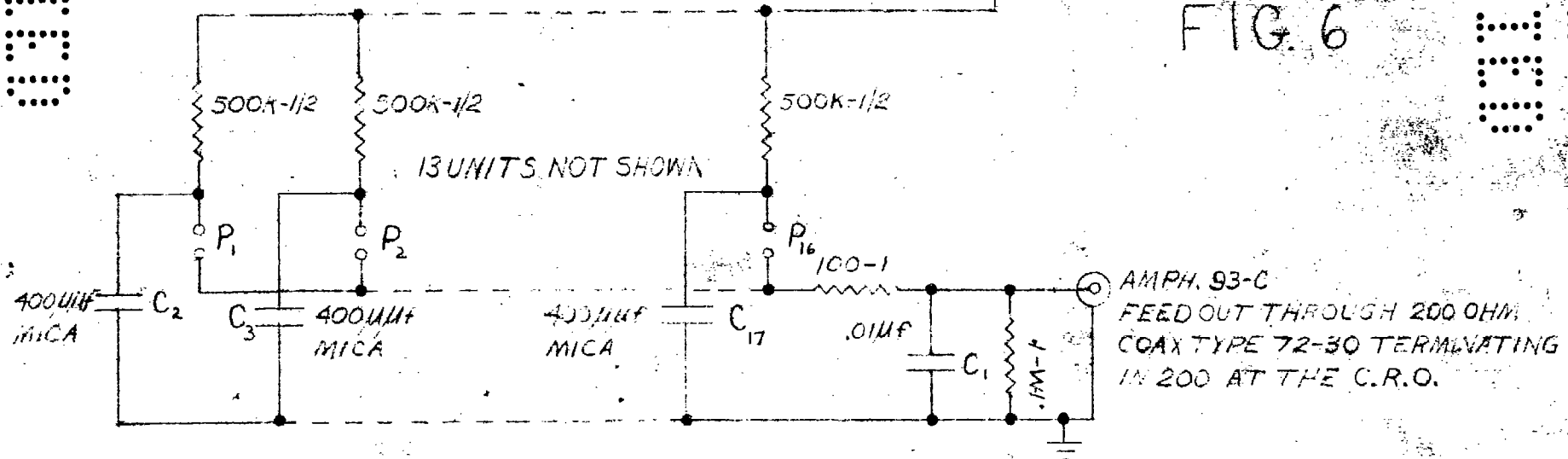

FIG. 6



E.W. TITTERTON G-4
HME 10/20/44

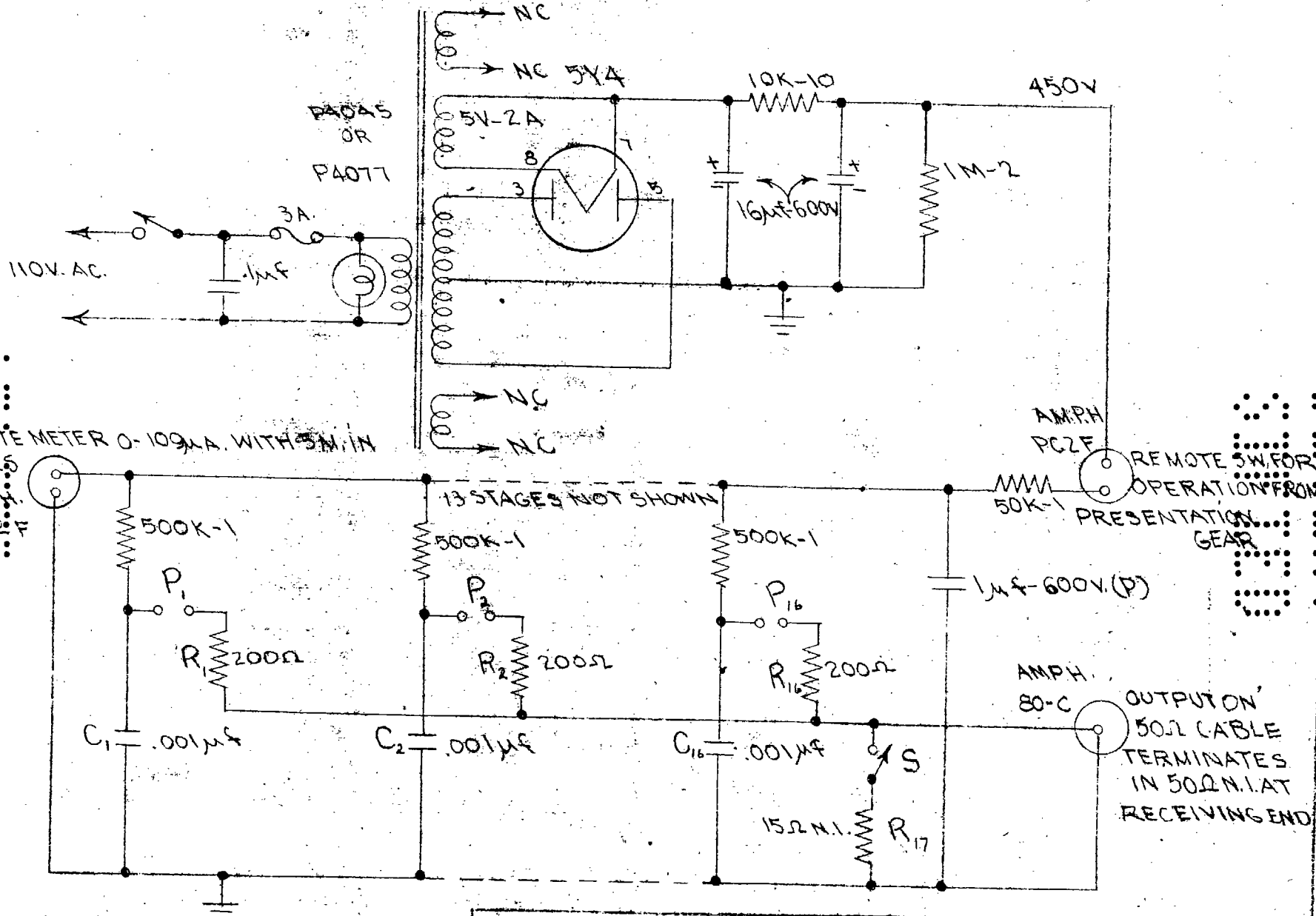

FIG. 7

DESIGNED BY E.W. TITTERTON	GROUP C-4
DRAWN BY HMB	DATE 1/18/44

TITLE: FAST PIN MIXER

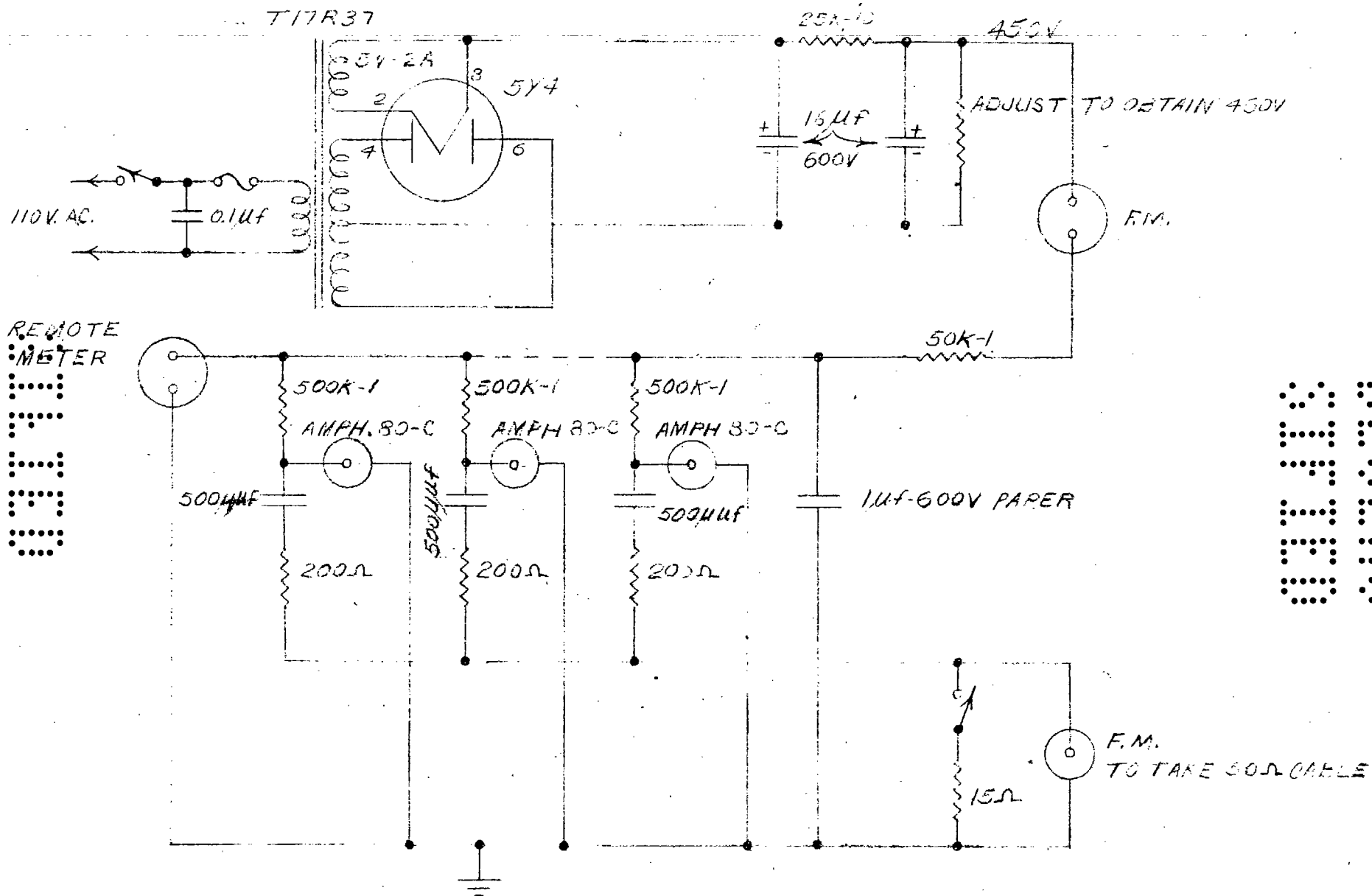

FIG. 8

DESIGNED BY E.W. TITTERTON G-4
H.M.B. 2/745

522

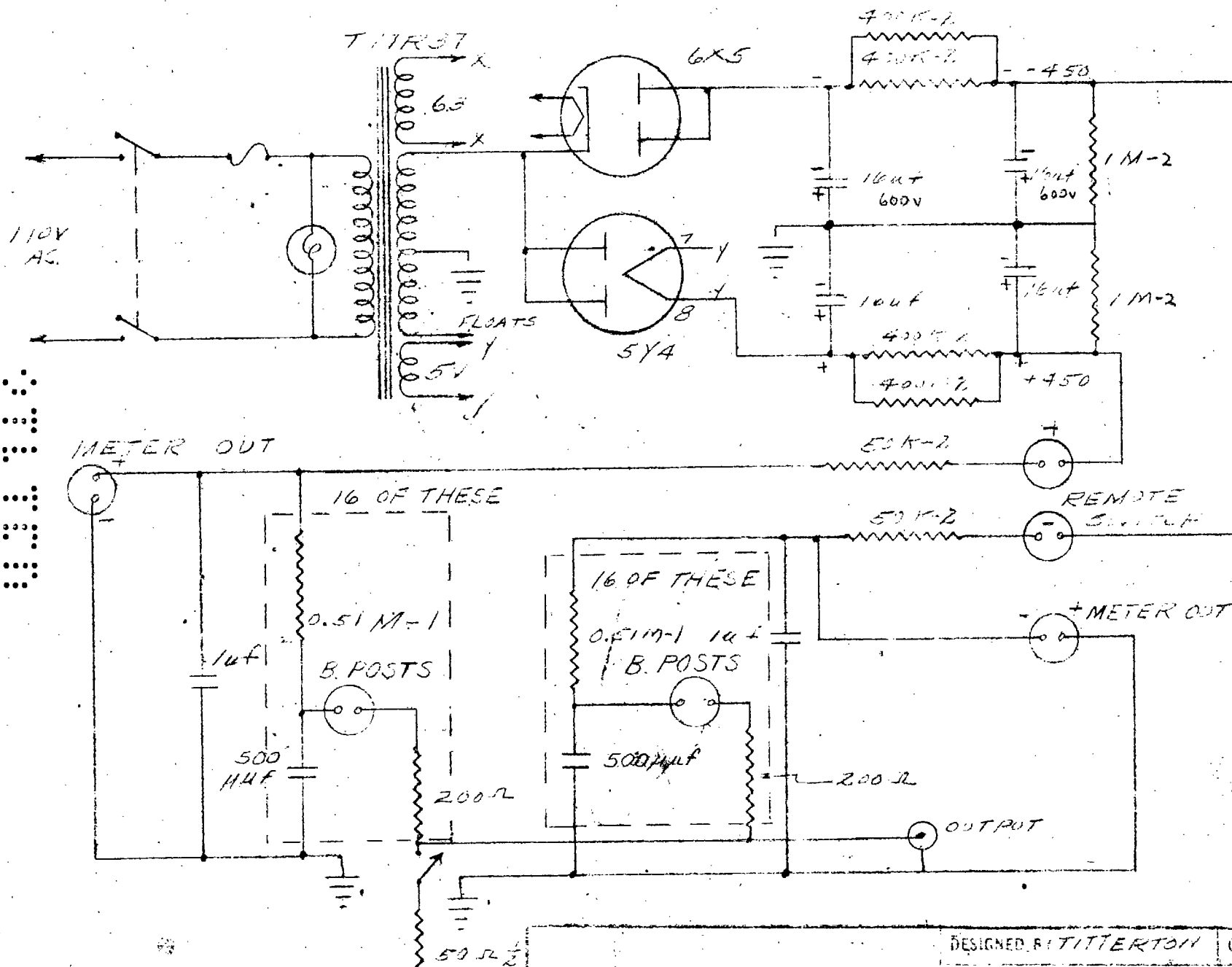

FIG 9

DRAWING NO.

515-A

DESIGNED BY TITERTON GROUP G-4

DRAWN BY HDL DATE 2-3-45

TUBE SPEC. 40 PIN

MIXER (FLUX-MINUS)

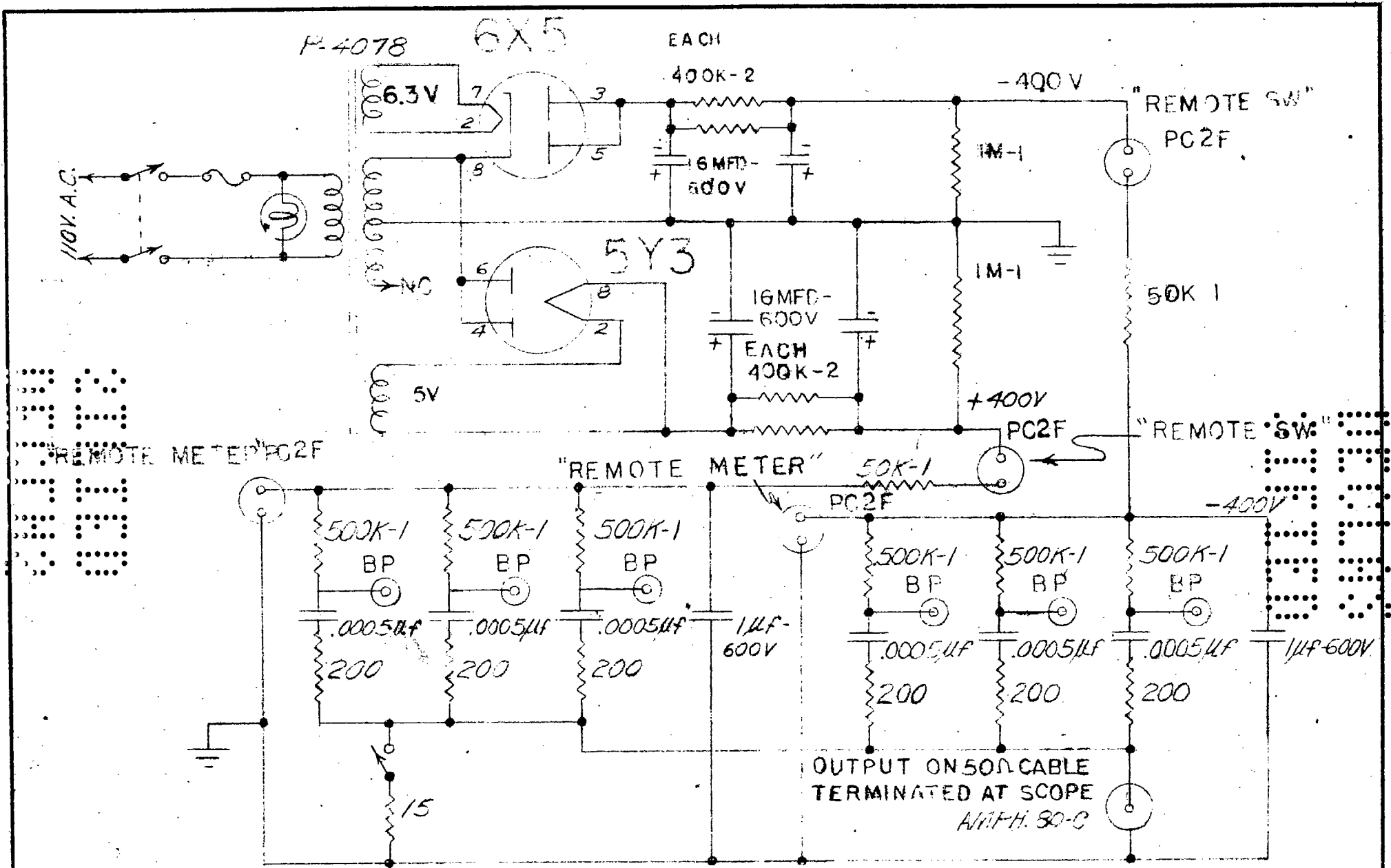

B.P. IS BINDING POST

FIG. 10

DESIGNED BY W TITTERTON	GROUP G4
DRAWN BY HMB	REV. 7-30-45

MIXER FOR JET STUDIES

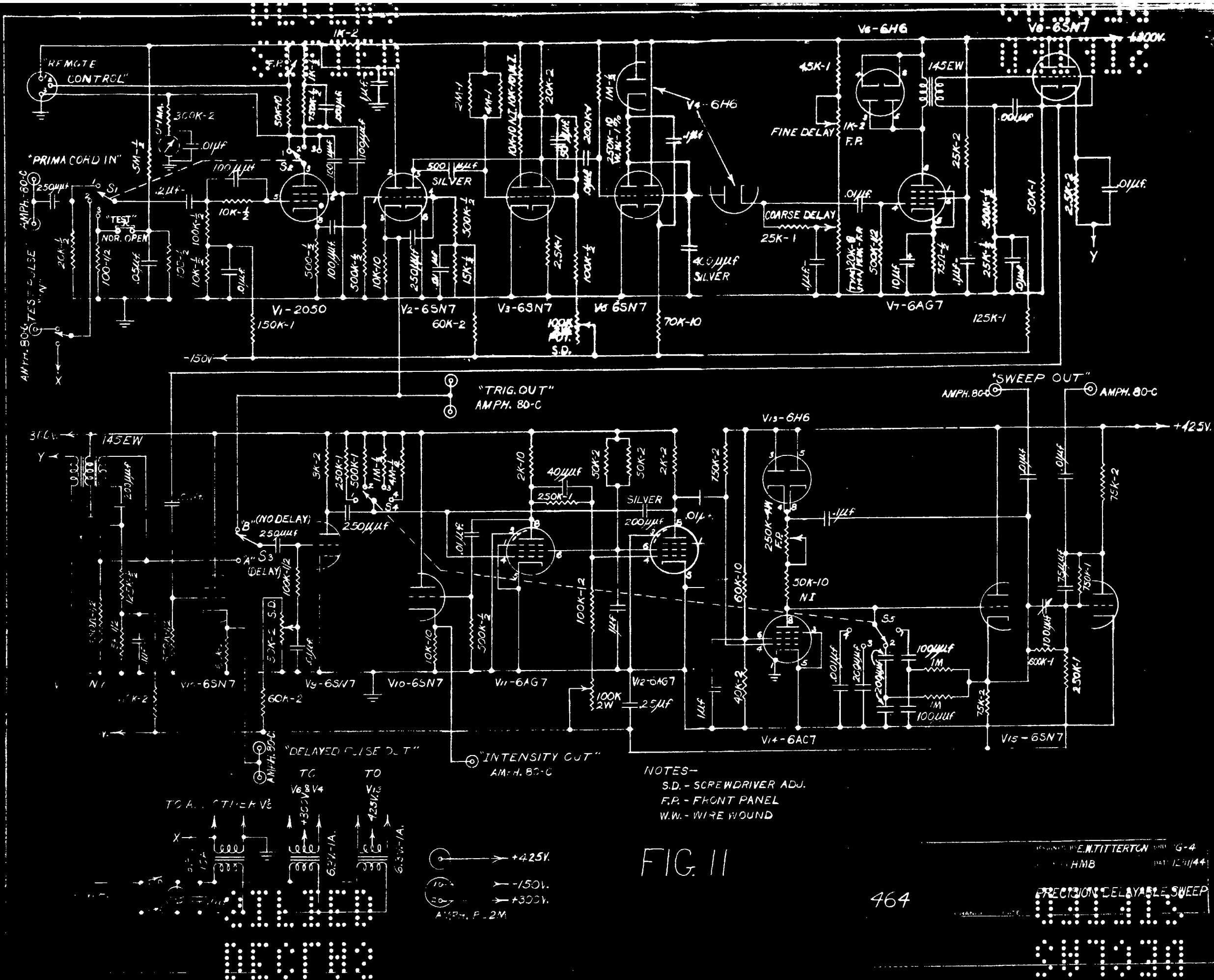

NOTE: CONDENSER VALUES & RATINGS ARE NOT OPTIMUM VALUES. AVAILABLE STOCKS HAD TO BE USED.

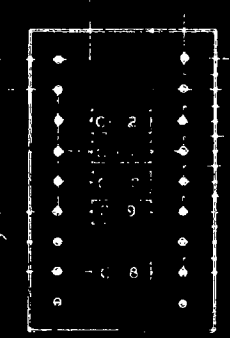
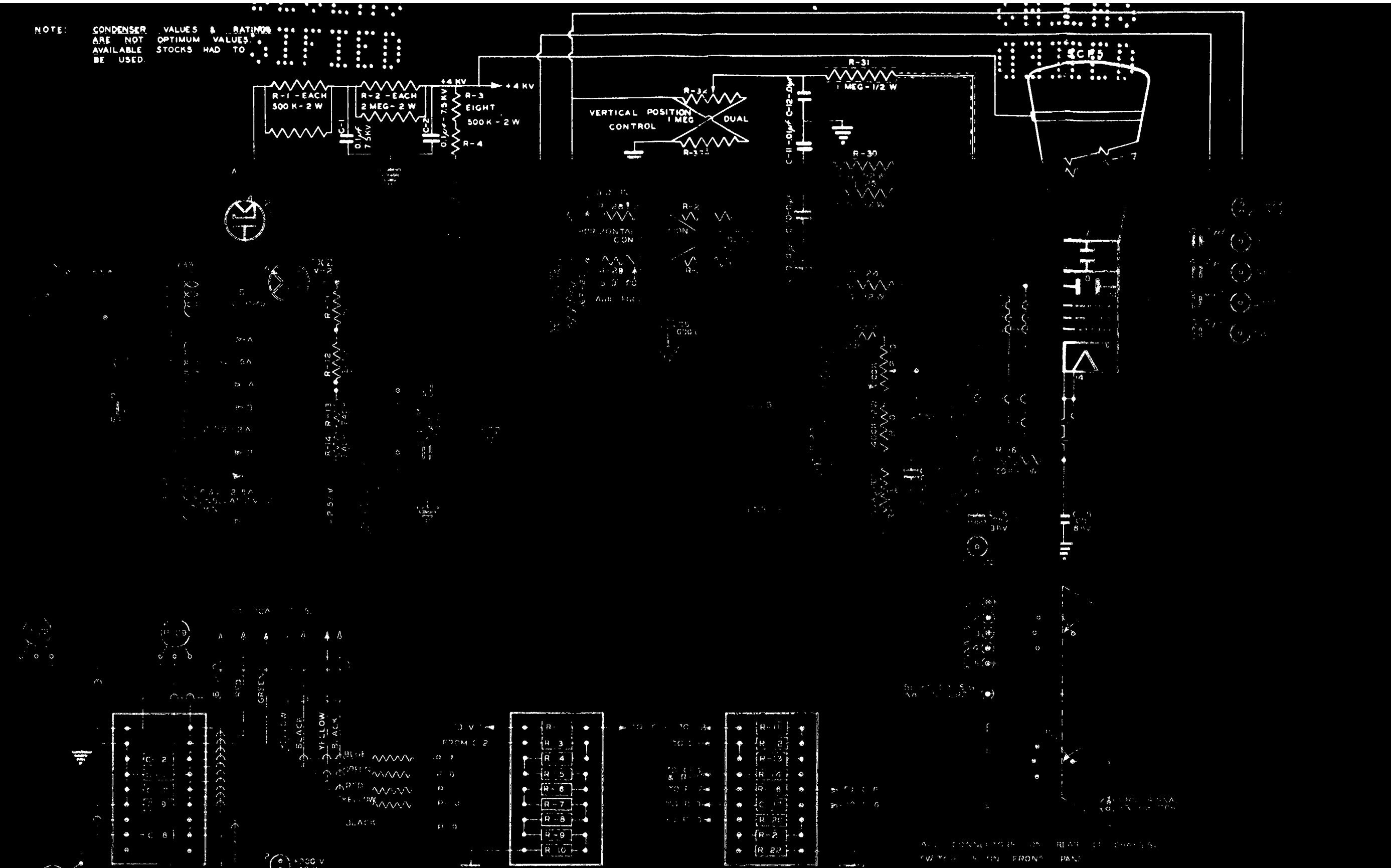

NO. 1

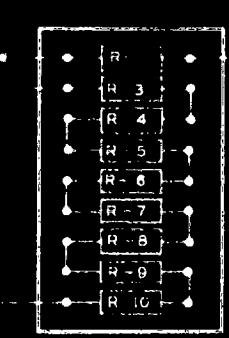

NO. 2

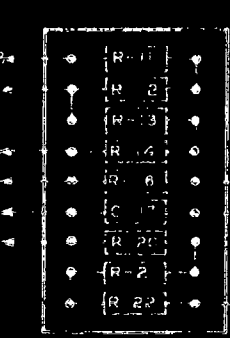

NO. 3

STRIP LAYOUTS

RANGE 100 OHMS OTHERWISE NOTED
NEW TITERTON
DATE
GRANGE 2

CHANGE 1 EM WAS
PART NAME
HIGH VOLTAGE
DRAWING NO.
SHT #
Y-12-65C-1A

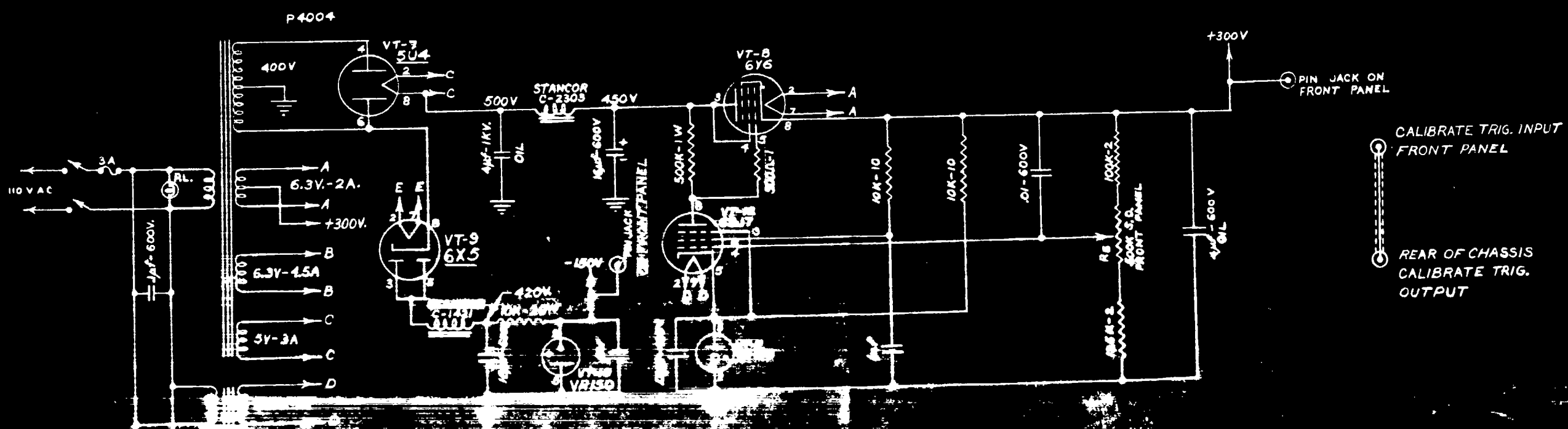
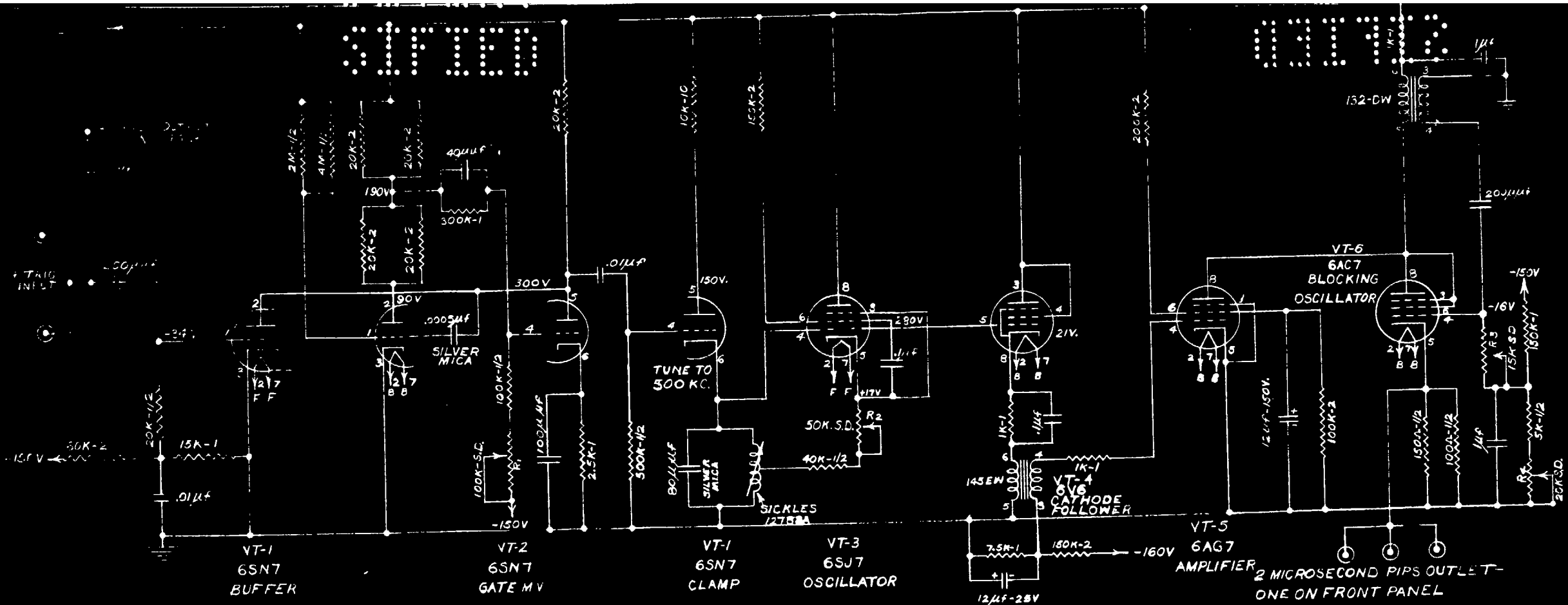

FIG. B

DESIGNED BY	DATE
DRAWN BY	DATE
CHECKED BY	DATE
DRAWING NO.	393

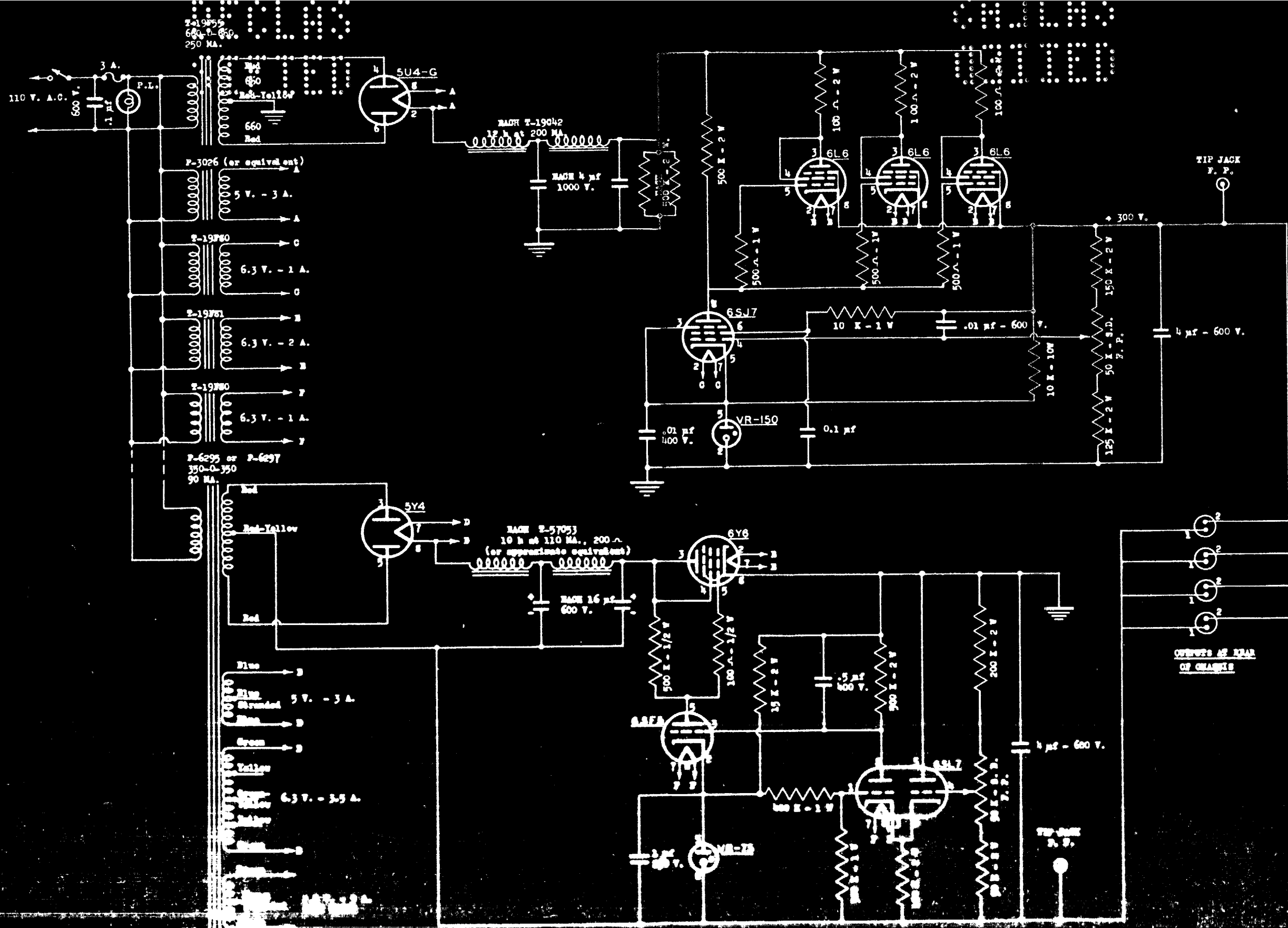

FIG 14

UNCLASSIFIED

031700

DOCUMENT ROOM

REC. FROM *el*

DATE 9/11/45

REC. NO. REC. ✓

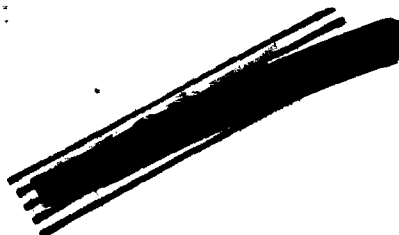

UNCLASSIFIED

031700