

APT He-3 TARGET LEAD STACKED PLATE CONFIGURATION

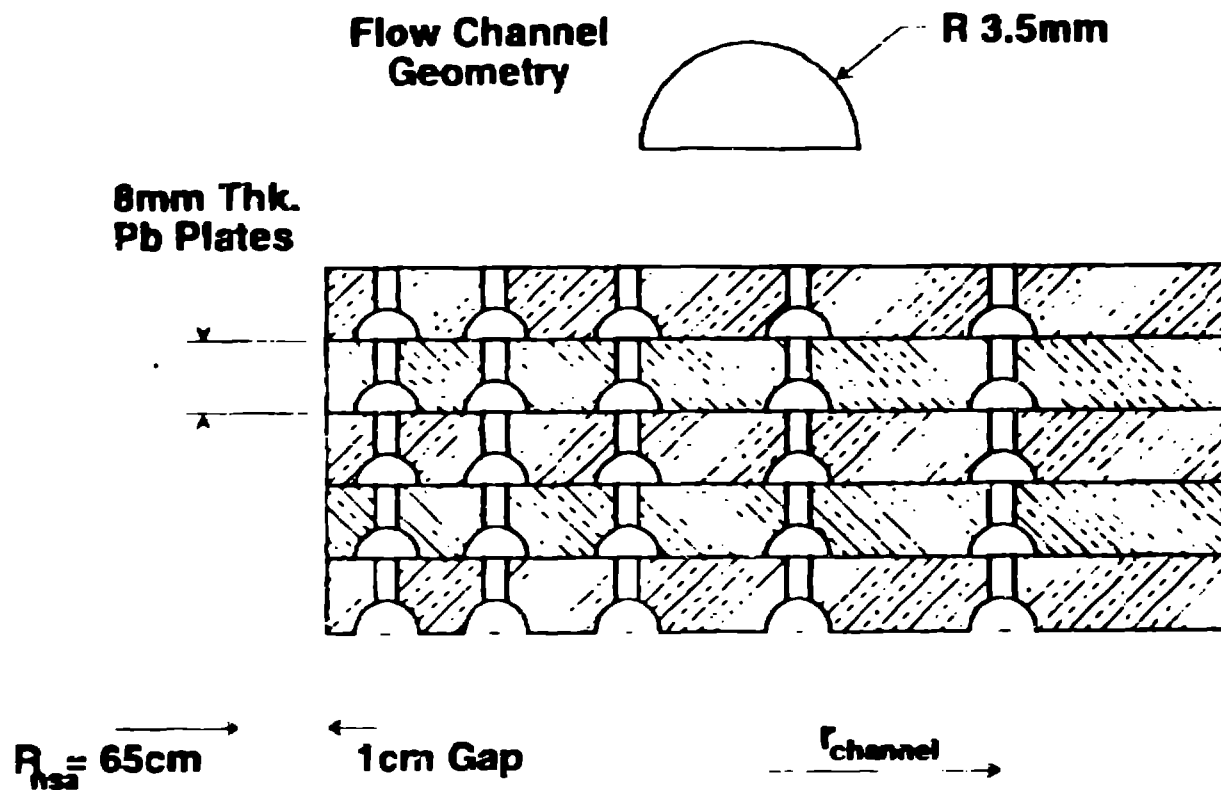

02-3100910

APT-LANL

D20 Fraction in Target Lead Side

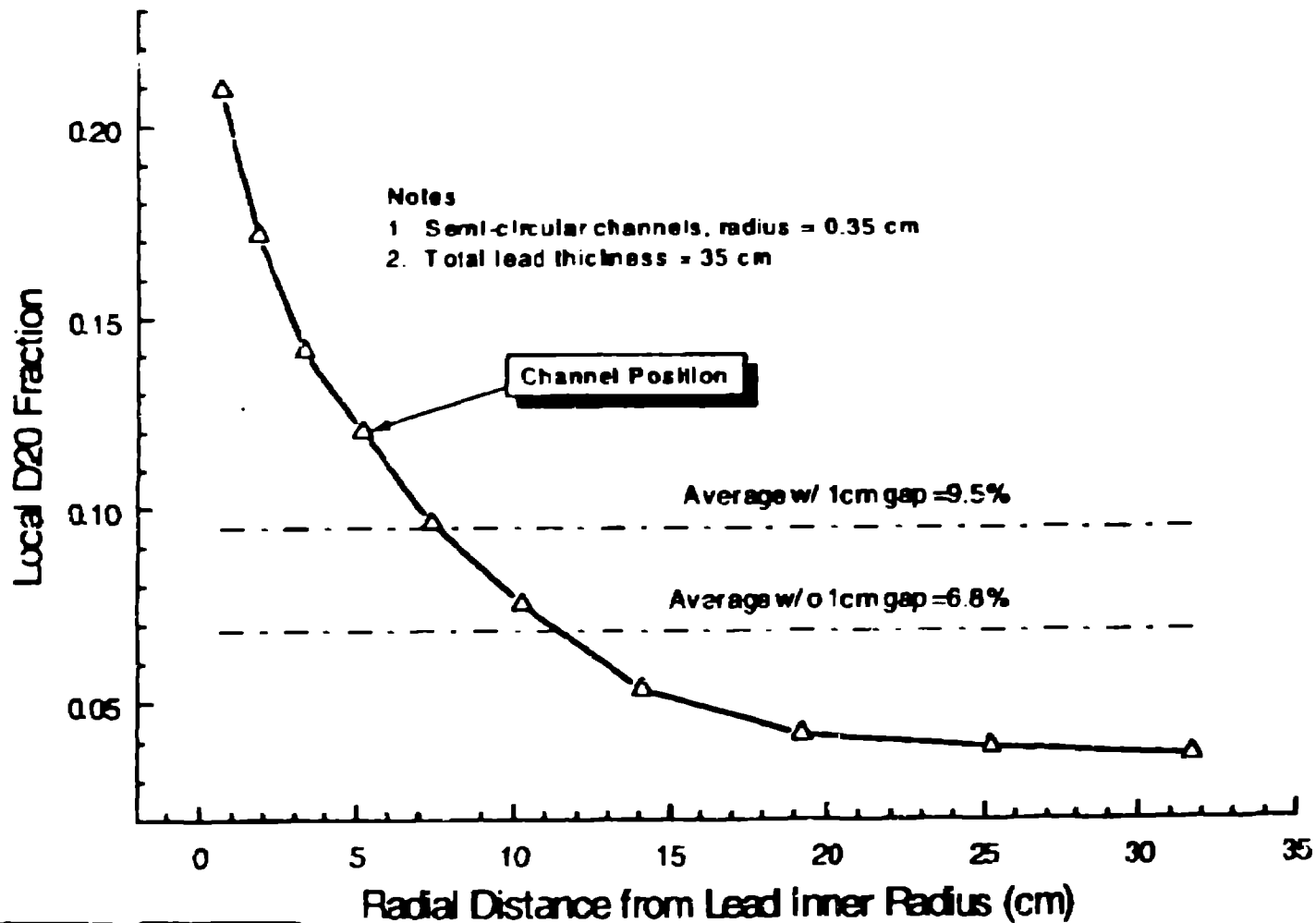

CONFIDENTIAL - SECURITY INFORMATION - NOT BE RELEASED TO THE PUBLIC

TARGET LEAD

□ Heavy Water Volume Fraction	10%
□ Inconel Volume Fraction	3%
□ Equivalent Lead Thickness	30 cm
□ Peak Operating Power Density	48 W/cc
□ Peak Operating Lead Temperature	102 °C
□ Peak Decay Heat (1 sec) Lead Temp.	84 °C
□ Lead Melt Temperature	327 °C
□ Lead Coolant Temperature	
- Inlet	50 °C
- Outlet	70 °C
□ Peak Operating Coolant Velocity	2 m/sec
□ Pressure Drop	35 kPa
□ Max Primary Tensile Stress in Lead	175 kPa
□ Lead Mass - Half Section	45 MetricTons
□ Coolant pD	Neutral



McGraw-Hill
Advanced Systems Engineering
P. 12

MODERATOR TANK & INTERNALS

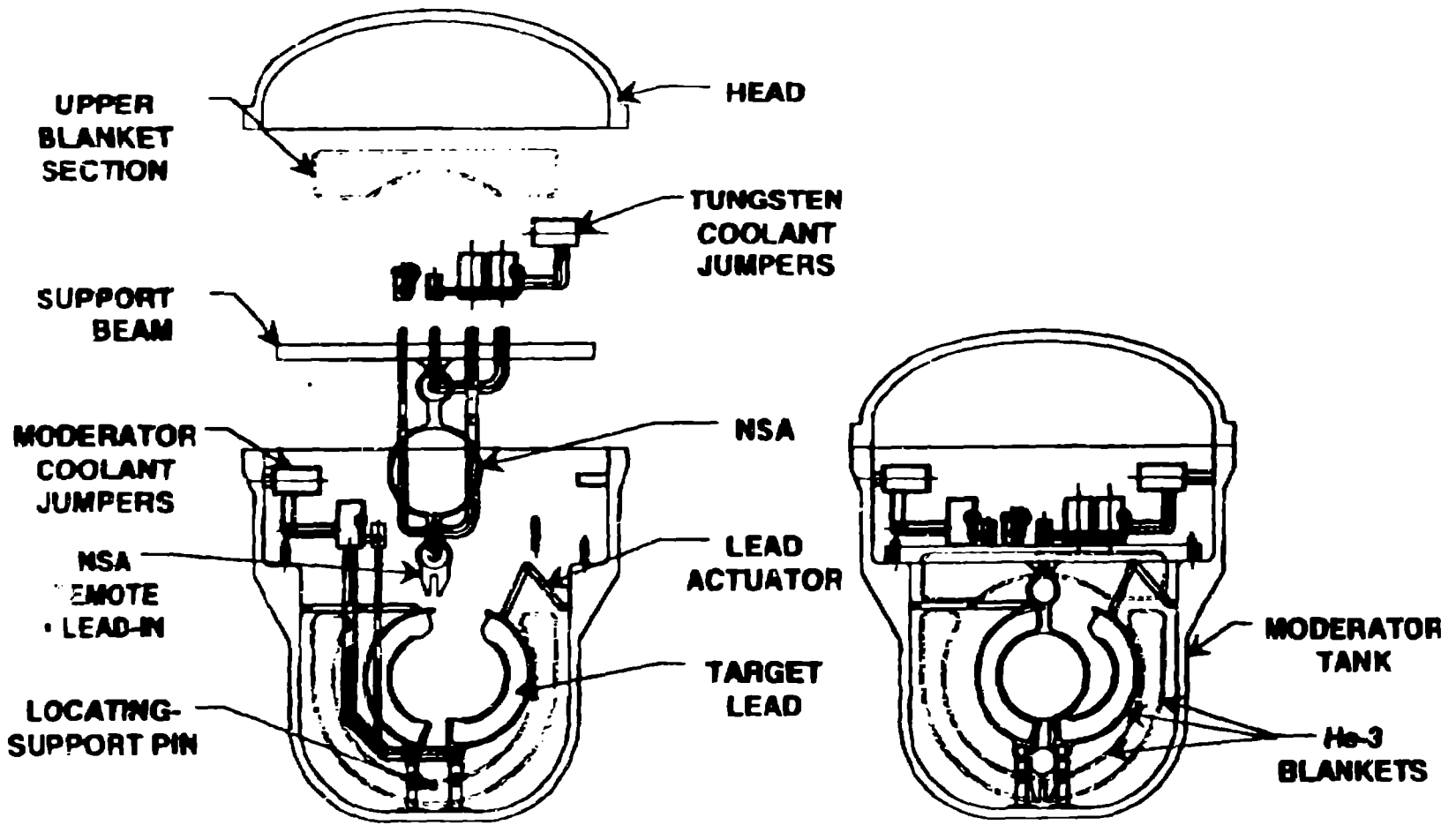

02-3100910

REMOTE HANDLING JUMPERS

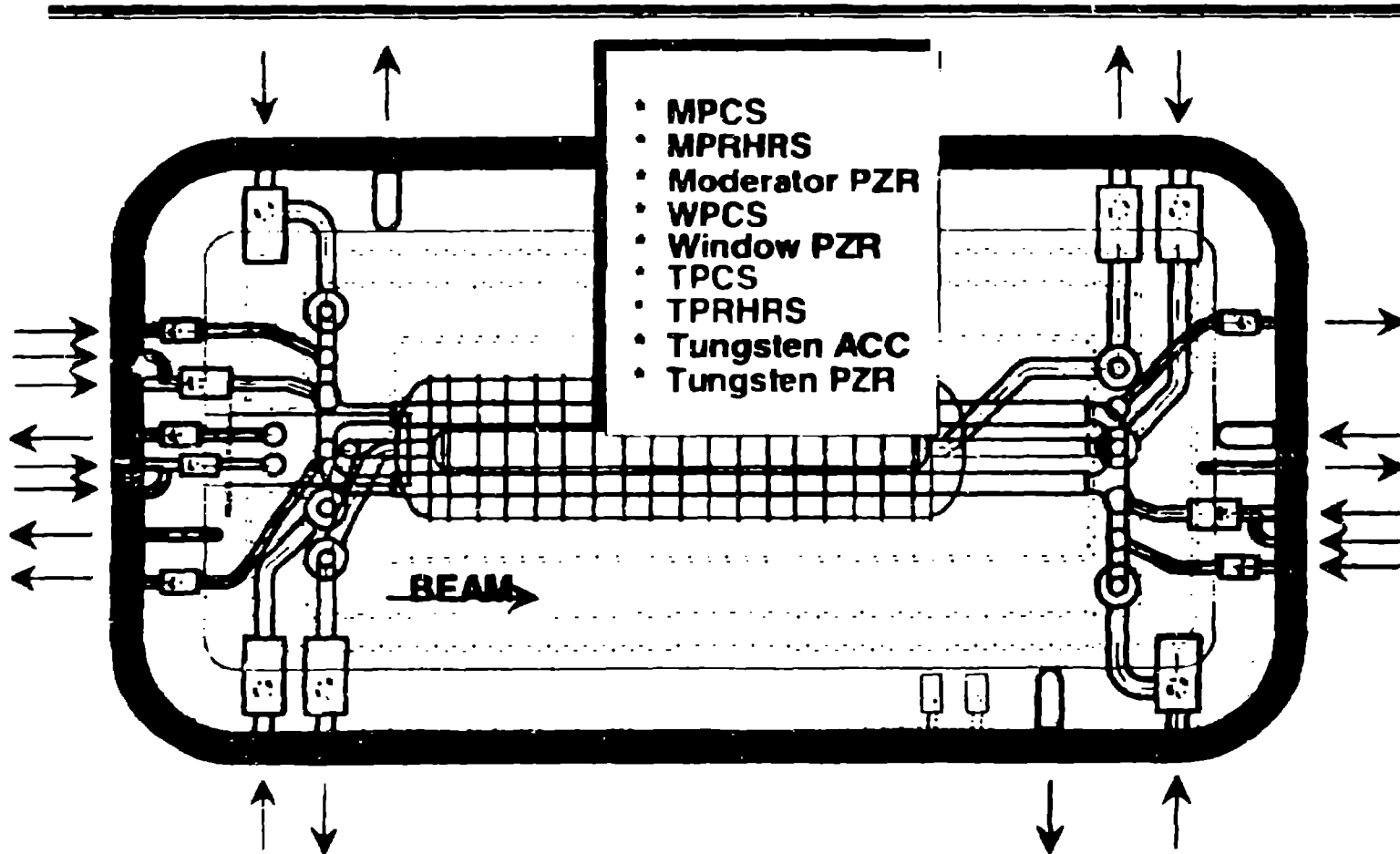

- Blanket, NSA, Backstop Helium (Not Shown)
- instrumentation (Not Shown)

02-3100910

REMOTE HANDLING JUMPERS

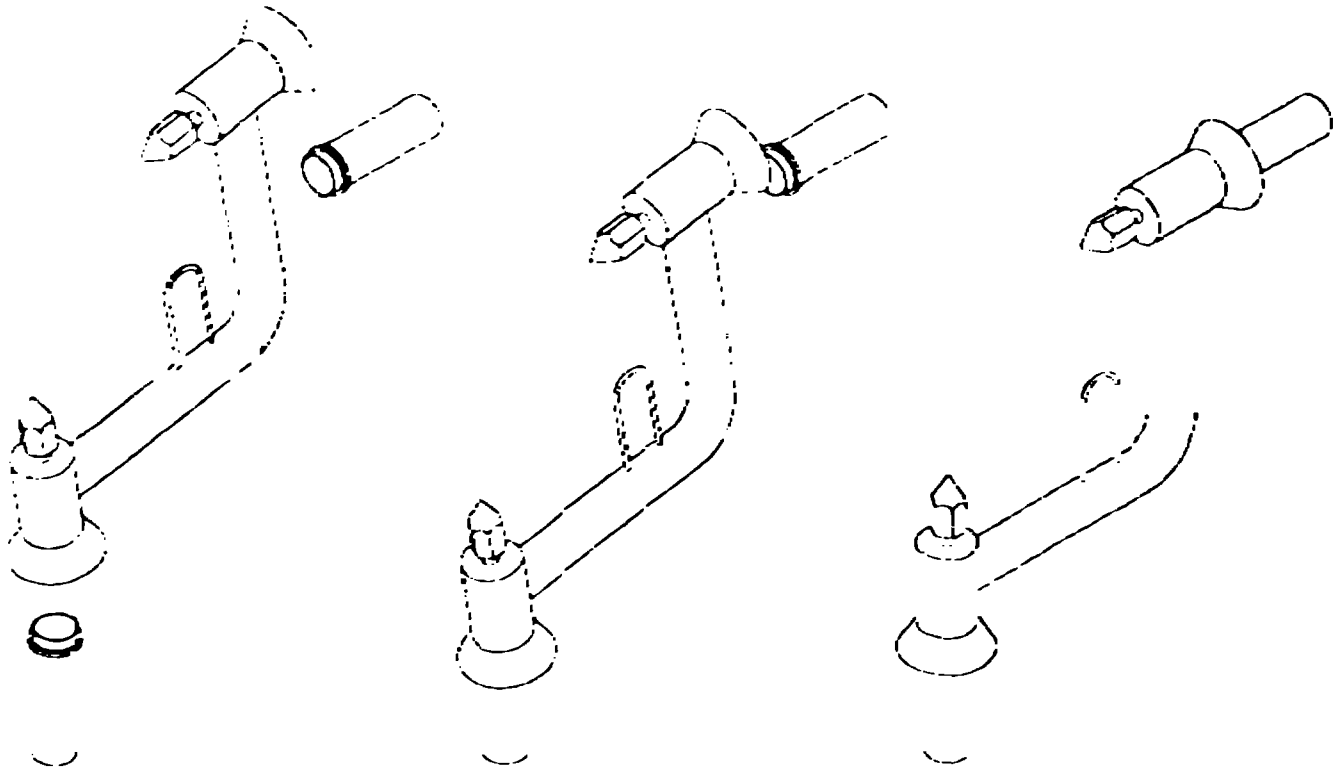

APT HE-3 REMOTE HANDLING

Hanford - Purex 3
Jaw Connector

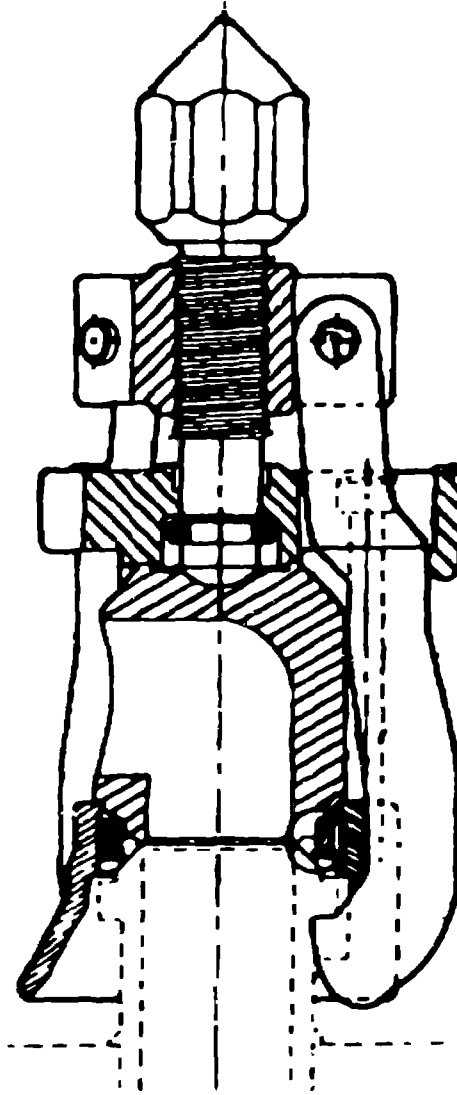

M

Support & Safety
Advanced System Engineering

RE-TARGETING SEQUENCE

- ❑ A step-by-step replacement sequence developed based on current target-facility design
- ❑ Equipment, access and laydown requirements identified based on replacement sequence
 - Relatively simple equipment required
 - Next step to coordinate with Bechtel
- ❑ Spent target can be transported in air (or water) with heat rejected to ambient
 - Spent target can remain in air indefinitely
 - Utilizes a reusable fin tube coolers(s) connecting target inlet and outlet
 - D20 can be reused; saves \$200-300K per target

TARGET DISASSEMBLY SEQUENCE

- A step-by-step target disassembly sequence developed based on current target-storage pool design
- Equipment, access and laydown requirements identified based on disassembly sequence
 - Relatively simple equipment required
 - All cutting / moving equipment are commercial adaptations
 - Next step is to coordinate with Bechtel
- Equipment / sequence same with separate or combined disassembly pools
 - Combined pool eliminates need to move equipment

SAFETY

The APT System has the following inherent features that contribute significantly to its safety and simplify its design:

- The Target / Blanket Design contains no fissile material. Nuclear criticality and re-criticality are not design concerns**
- Beam trip is fast and reliable**
- Residual heat is low**
- Radioactive inventory is low**

The APT System is a high energy system and requires appropriate control and protection systems to maintain its performance and integrity and to protect worker and public personnel



BEAM TRIP / SFAS OVERVIEW

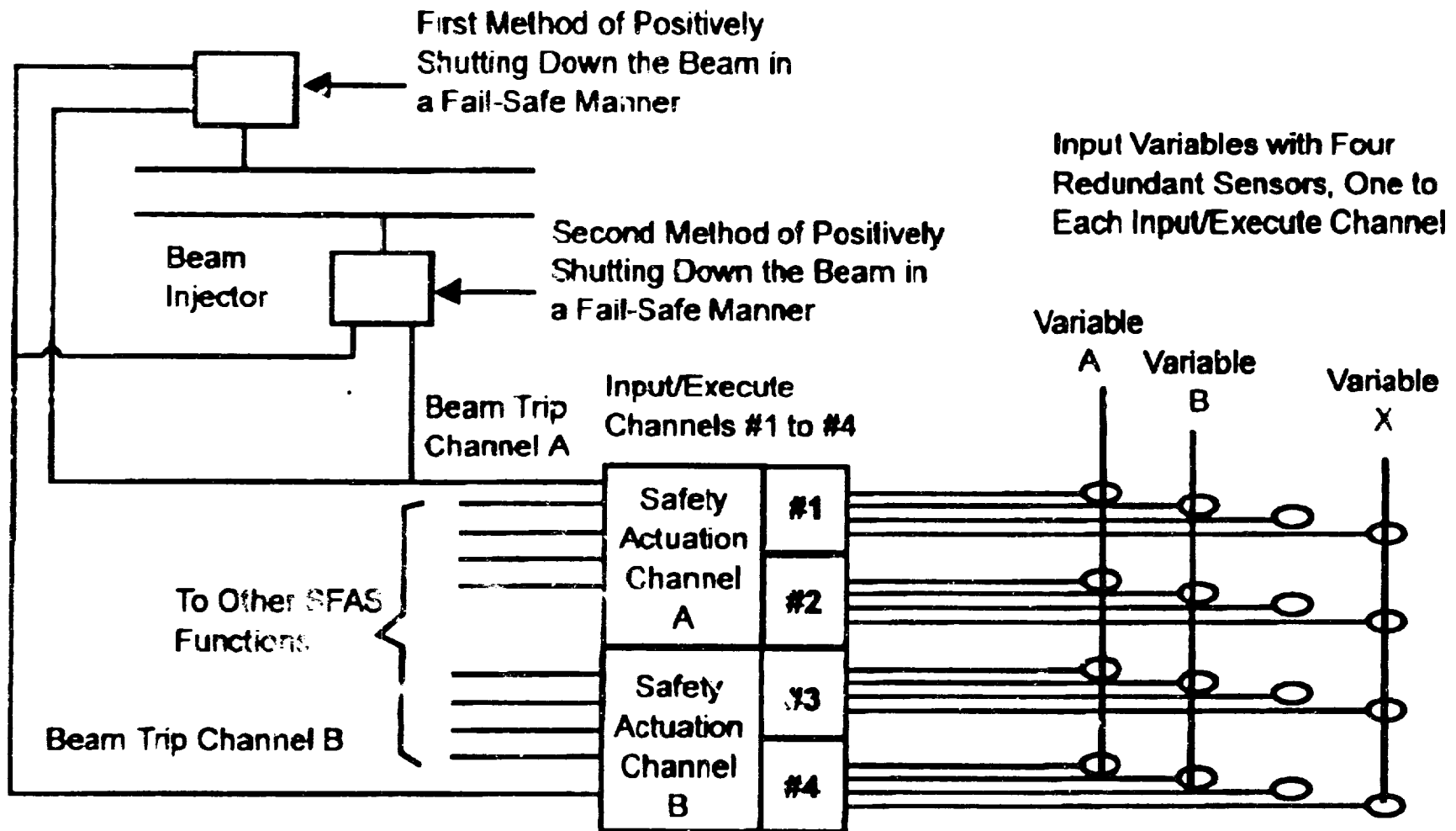

SYSTEM SAFETY PHILOSOPHY

- **Defense in Depth**
 - **Active Plus Passive Cooling Systems**
 - **Diverse, Redundant Backup Systems**
 - **Multiple Radionuclide Barriers**
- **System Safety Requirements Document**

SYSTEM SAFETY REQUIREMENTS

- ❑ **Fast and Reliable Beam Trip**
- ❑ **Smooth Transition to Safety Systems**
 - Provide Extended Pump Coastdown
 - Flood Heat Source
- ❑ **Active Residual Heat Removal Systems**
 - Use Multiple Loops / Components
 - Maintain Adequate Net Pump Suction Head
 - Provide backup Diesel Power
- ❑ **Natural Circulation Cooling**
 - Specify Component Elevations
 - Preclude Gas Flow Blockage
 - Use Air / Water Heat Exchangers



TARGET/BLANKET/WINDOW HEAT REMOVAL SYSTEMS

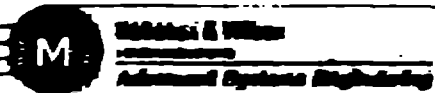
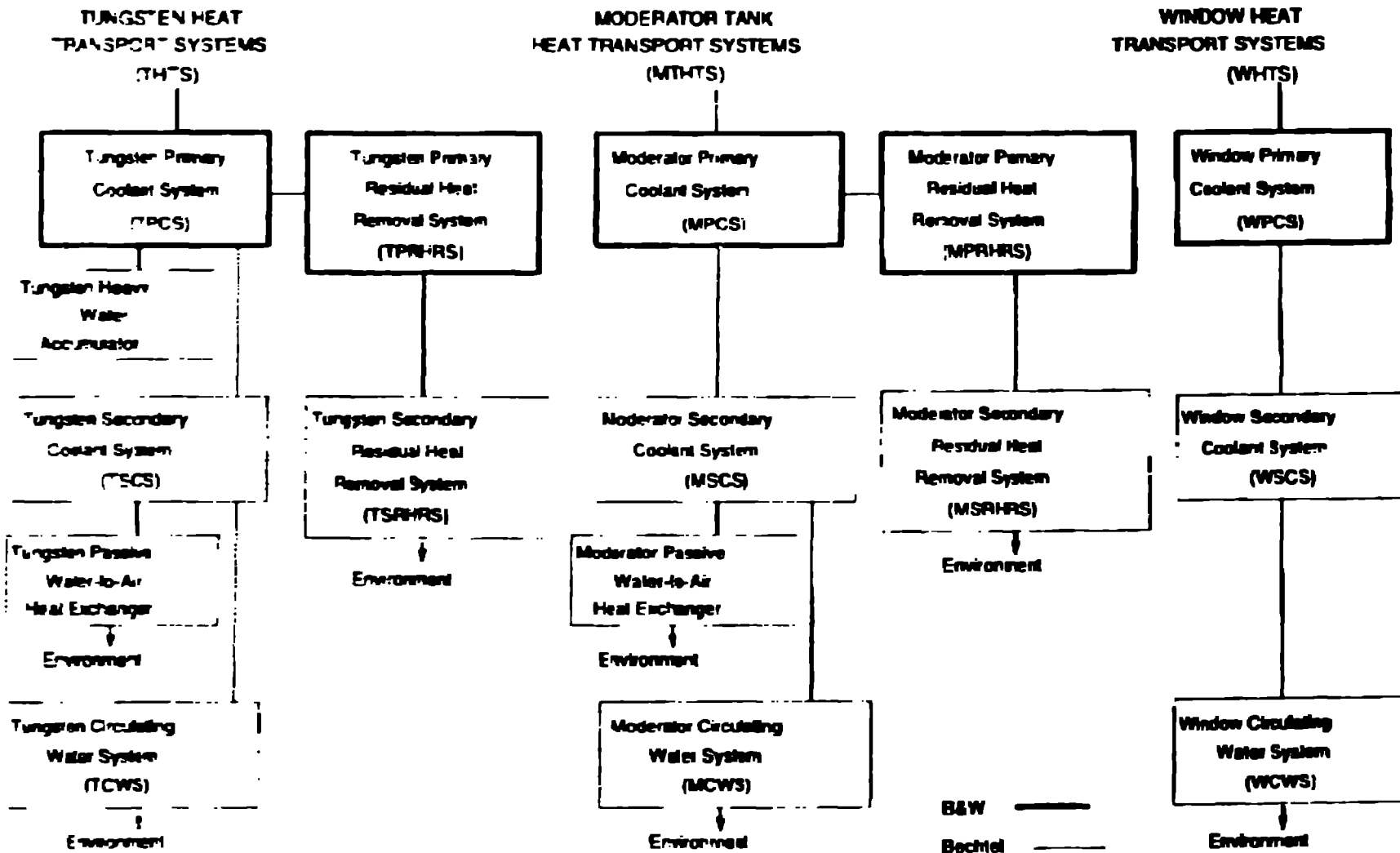

TUNGSTEN HEAT TRANSPORT SYSTEMS (THTS)

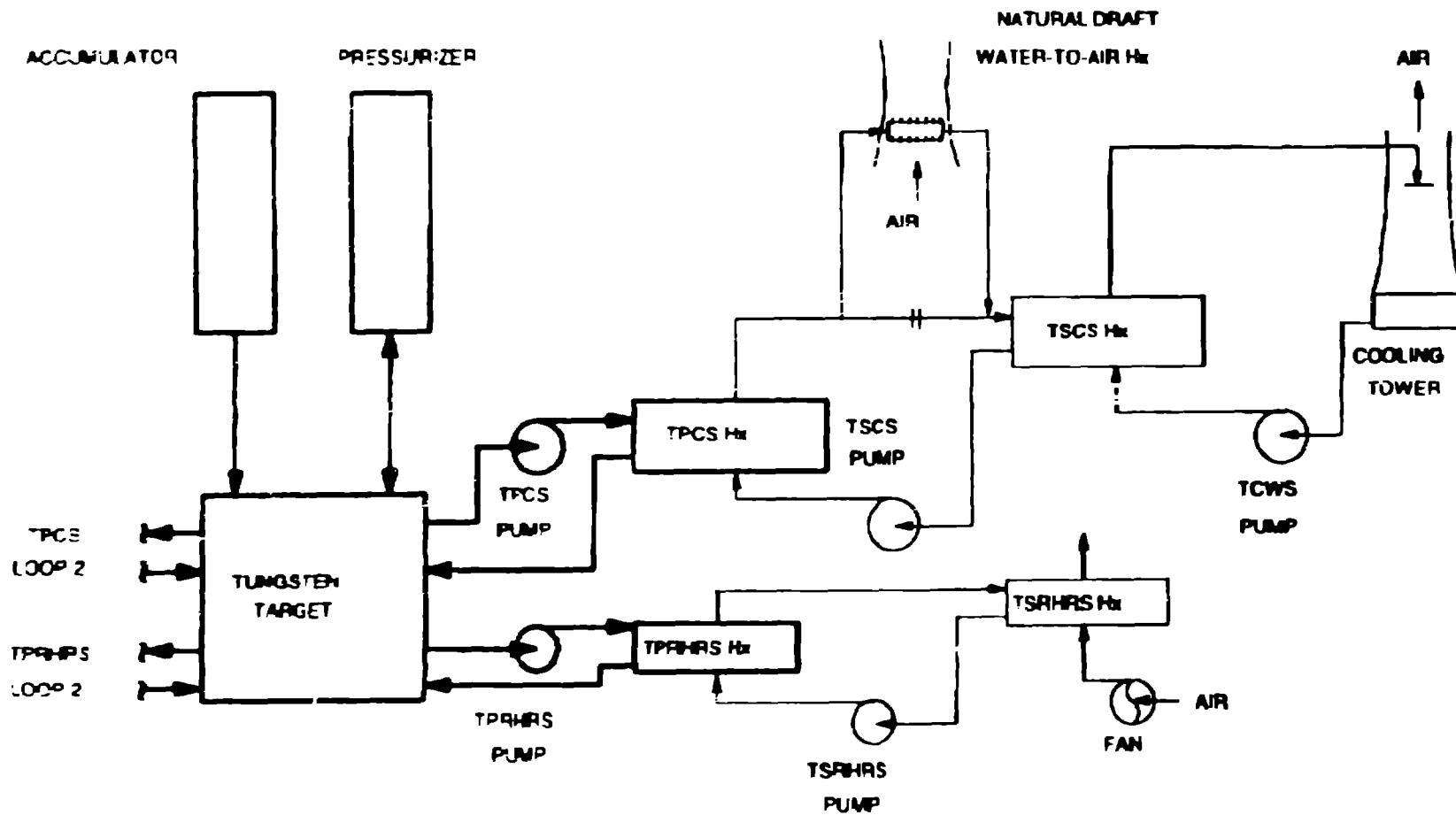

TUNGSTEN PRIMARY COOLANT SYSTEM

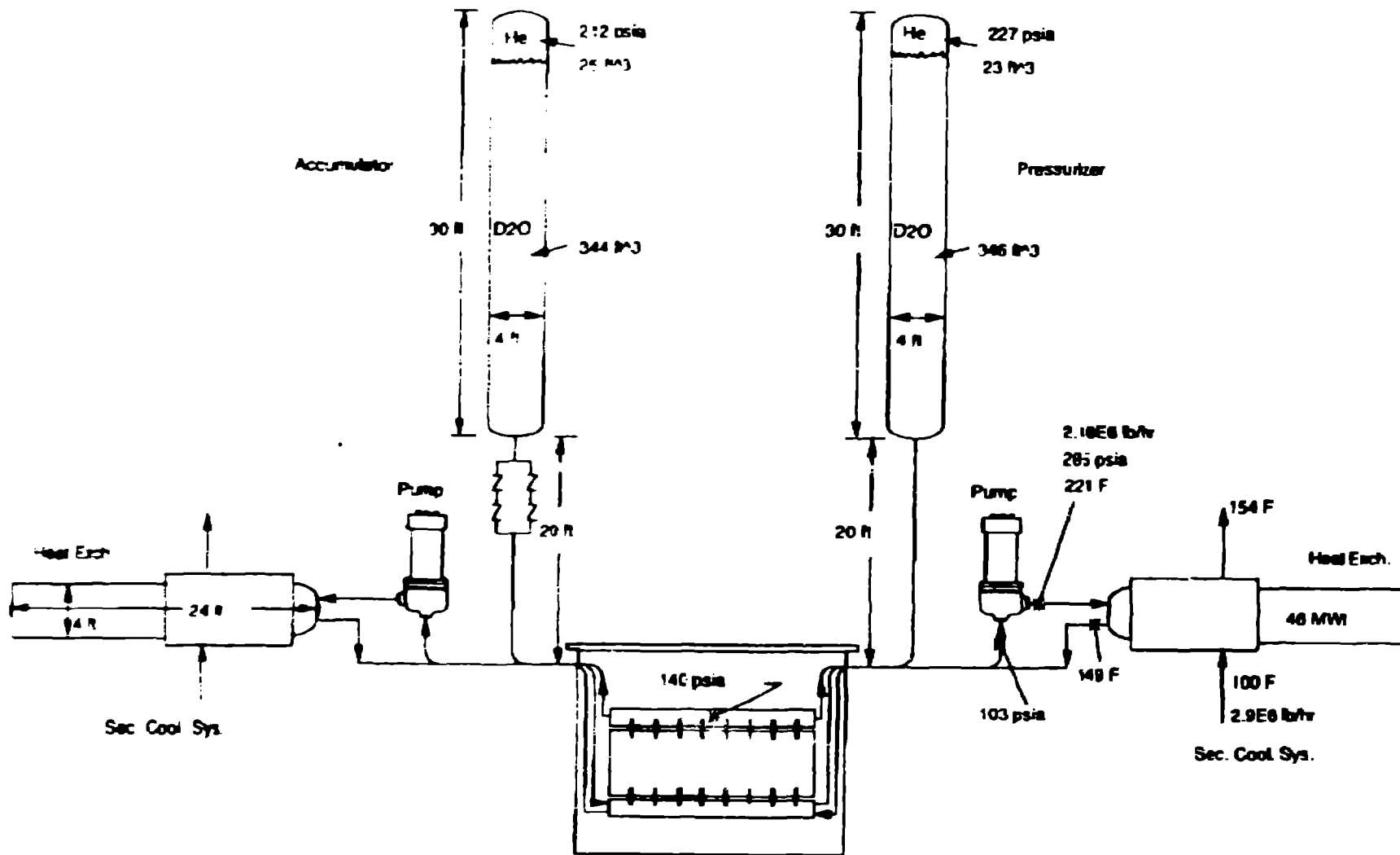

WINDOW HEAT TRANSPORT SYSTEMS

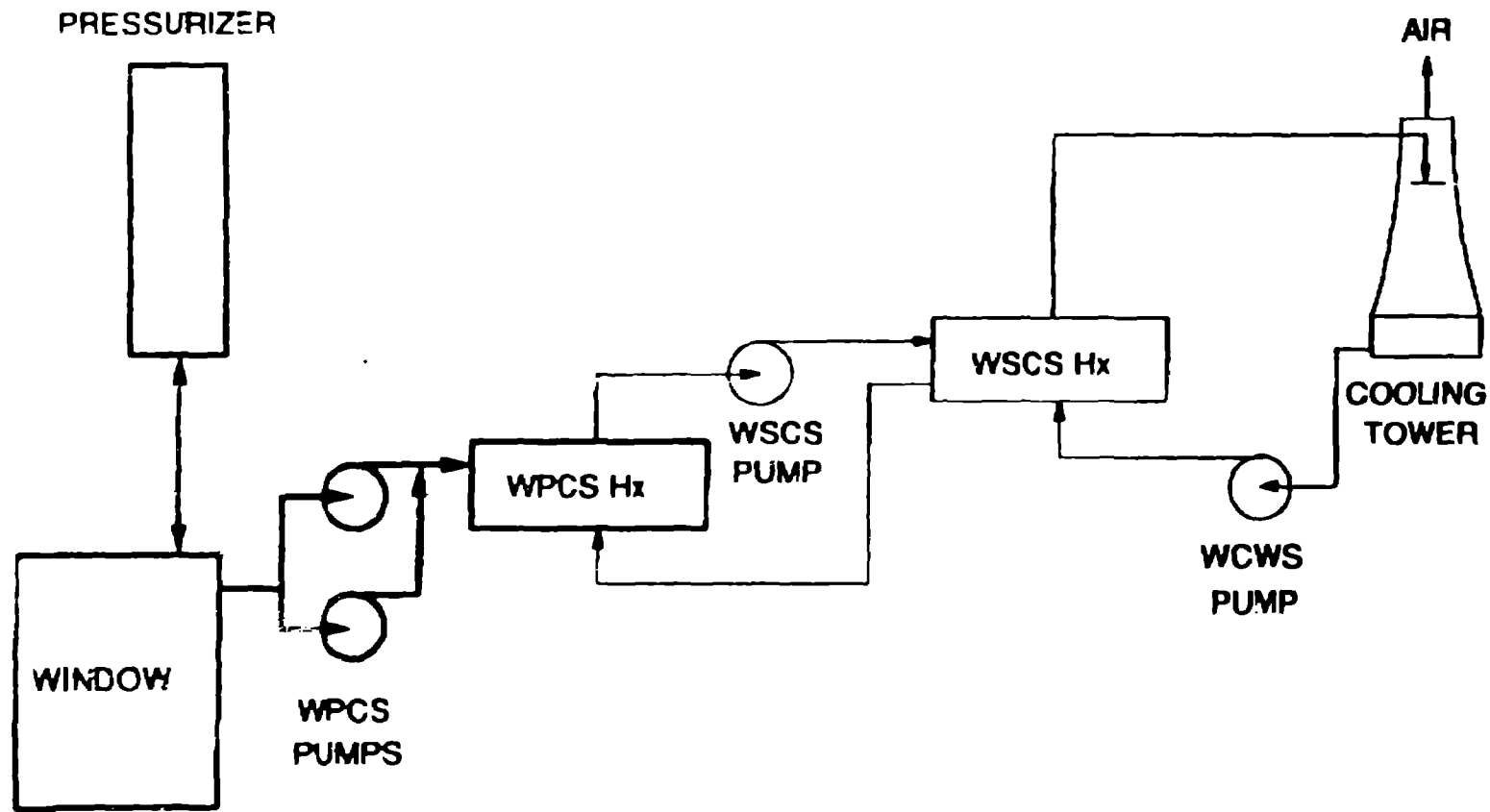

CONCLUSIONS

- Design concept is still evolving
- Heat Removal System is safe and uses well-proven technology
- Target/Blanket Assembly concept appears engineerable and producible
- Development Program is needed to provide essential data and to demonstrate performance
- Proceed with Conceptual Design

Tritium Processing Systems Accelerator Production of Tritium/He-3

**Tritium Technology Group
Los Alamos National Laboratory**

and

Merrick & Company

Presented by J. W. Barnes

June 1993

Experience Base (LANL-TSTA)

- Tritium Processing System (TPS) design is based upon 10 years experience with operation of the Los Alamos, Tritium Systems Test Assembly (TSTA).
 - ~ 100 kg tritium processed to date
 - ~ 130 g tritium inventory
 - ~ 300 Ci (0.03 g) tritium released to the environment
 - ~ 3 mRem/man-year exposure to operations personnel
- TSTA personnel provide design and operational assistance to the Princeton, Japanese and International fusion programs.
- TSTA personnel consult with DCE Defense Facilities on design and operation of tritium processing systems.

Experience Base (Merrick & Company)

- Merrick has extensive Tritium Process and Facility Design experience.
 - Tritium Systems Test Assembly
 - Weapons Subsystems Laboratory (LANL)
 - Replacement Tritium Facility
 - Weapons Complex Reconfiguration
 - Compact Ignition Tokamak (PPPL)
 - International Thermonuclear Experimental Reactor
- Merrick has design experience with DOE and DOE contractors at Argonne (ANL-W), Idaho, Oak Ridge, Rocky Flats, Richland, Savannah River, etc.
- Merrick personnel are familiar with LANL design philosophy and operations.

Design Philosophy

- Conceptual design is based upon a conservative application of demonstrated technology.
- Safety of operating personnel and minimization of environmental releases were the primary objectives during process selection and design (triple containment of tritium will be provided).
- Advanced concepts may be considered as alternatives if they offer potential for significant safety, cost or performance benefits.

APT/He-3 Tritium Processing

- All tritium processing is included within APT/He-3 site boundary.
- Tritium production system inventory is low for APT/He-3 (days) relative to alternative concepts (months to years). However, He-3 inventory is more mobile (gas) than alternative concepts (clad and chemically bound).
- APT/He-3 requires only a gas purification system (cost and safety benefits). Alternative concepts require high-temperature furnace systems for tritium extraction and produce significant quantities of high-level waste (Li/Al melt or graphite "flour").
- Environmental releases will be lower by several orders of magnitude compared with existing tritium processing systems (triple containment will be provided).

Tritium Processing System Accelerator Production of Tritium/He-3

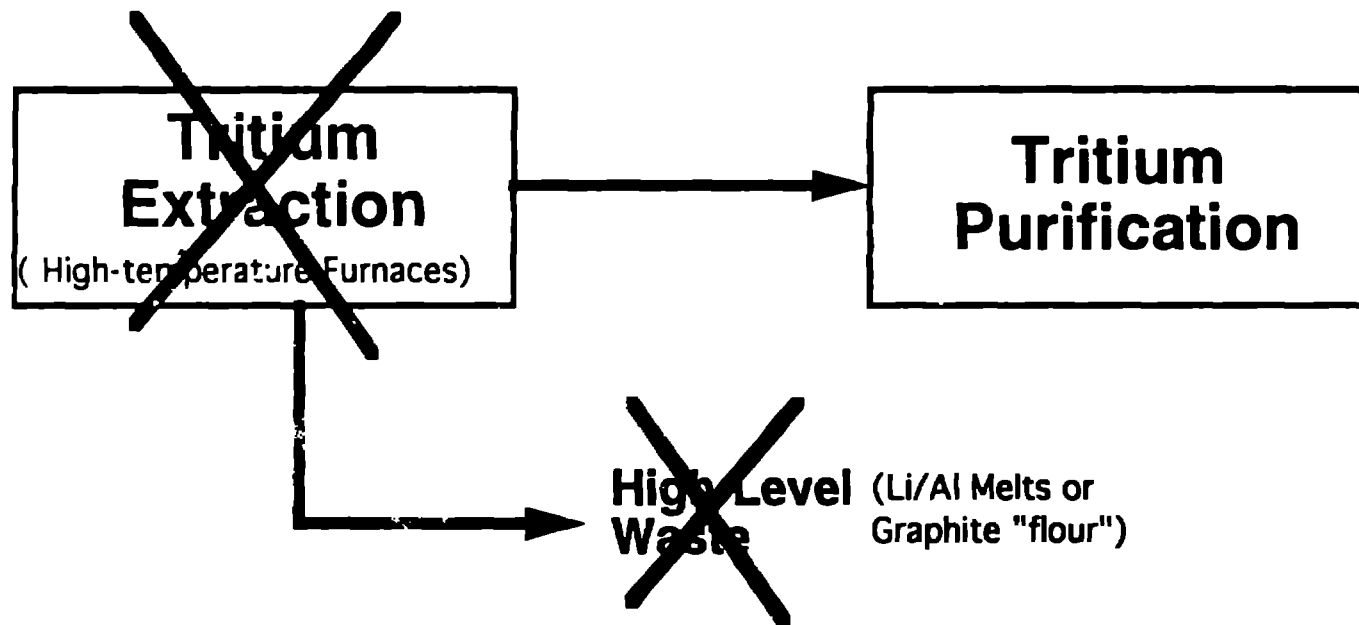

Flow Schematic Tritium Processing Facility

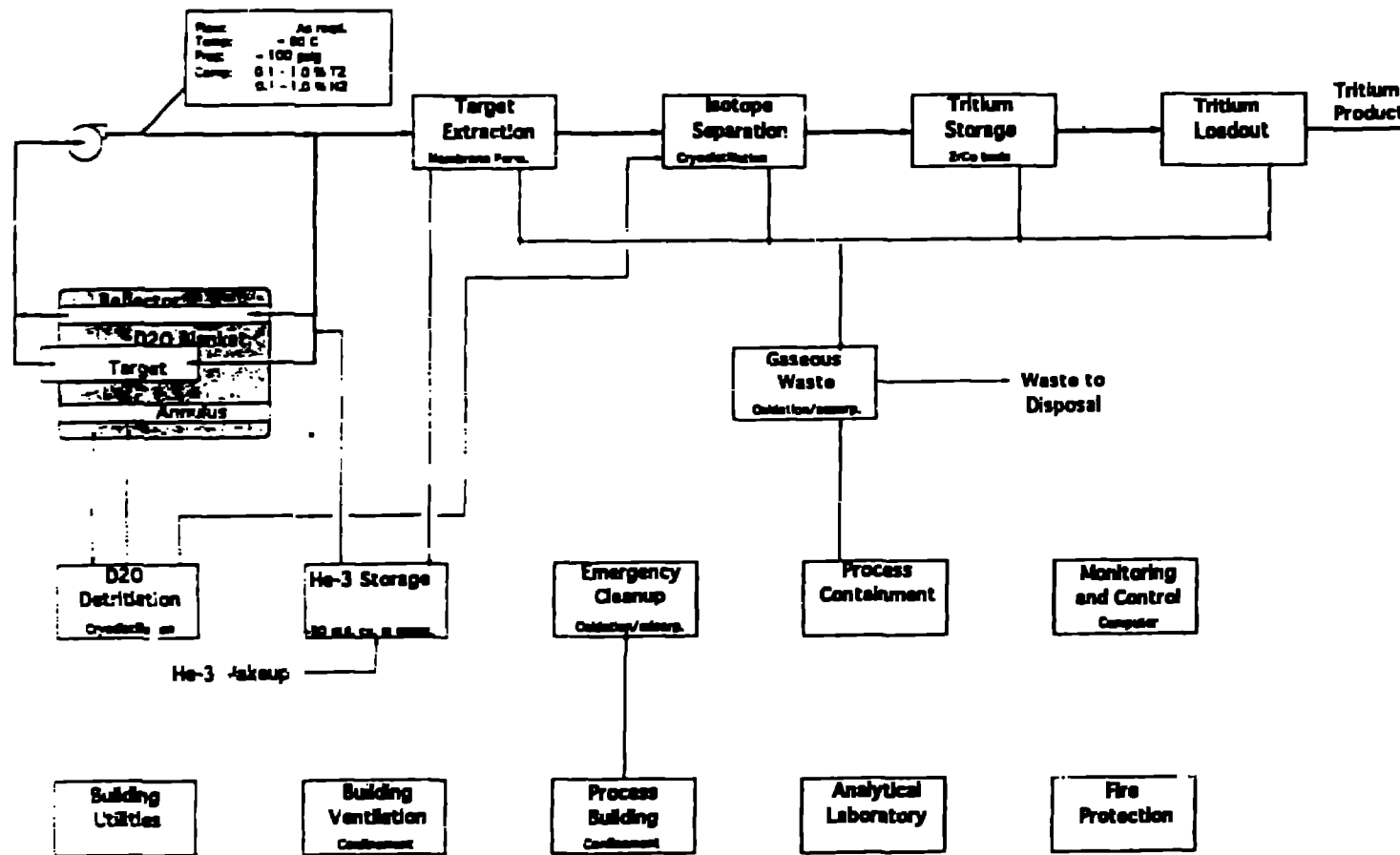

Tritium Process (Primary Systems) Technology

Tritium Extraction

- Hydrogen isotope extraction by membrane permeation; impurities removal by molecular sieve sorption.
- Scale-down of proposed fusion breeder technology currently demonstrated at Tritium Systems Test Assembly.

Isotope Separation

- Cryodistillation.
- Demonstrated at TSTA, Mound and Savannah River.

Tritium Storage

- Metal hydride storage for concentrated tritium.
- Evacuated tank storage for dilute tritium.

Tritium Load-out

- DOE "standard" Product Containers (sub-atmos. gas).
- Considering packaging for shipment as solid (hydride).

Tritium Process (Secondary Systems) Technology

D2O Detritiation

- Vapor Phase Catalytic Exchange; Cryodistillation.
- Sulzer technology; Selected for HWR.

Process Containment

- Catalytic oxidation with molecular sieve sorption of recovered water.
- Oxidation/sorption widely used.

Gaseous Waste

- Catalytic oxidation with molecular sieve sorption of recovered water.
- Oxidation/sorption widely used.

Emergency Clean-up

- Catalytic oxidation of confined process cell atmosphere with molecular sieve sorption of recovered water.

Helium-3 Load-in and Storage

- Gas bottle packaging.
- Tankage with secondary and tertiary containment.

Moderator Detritation System

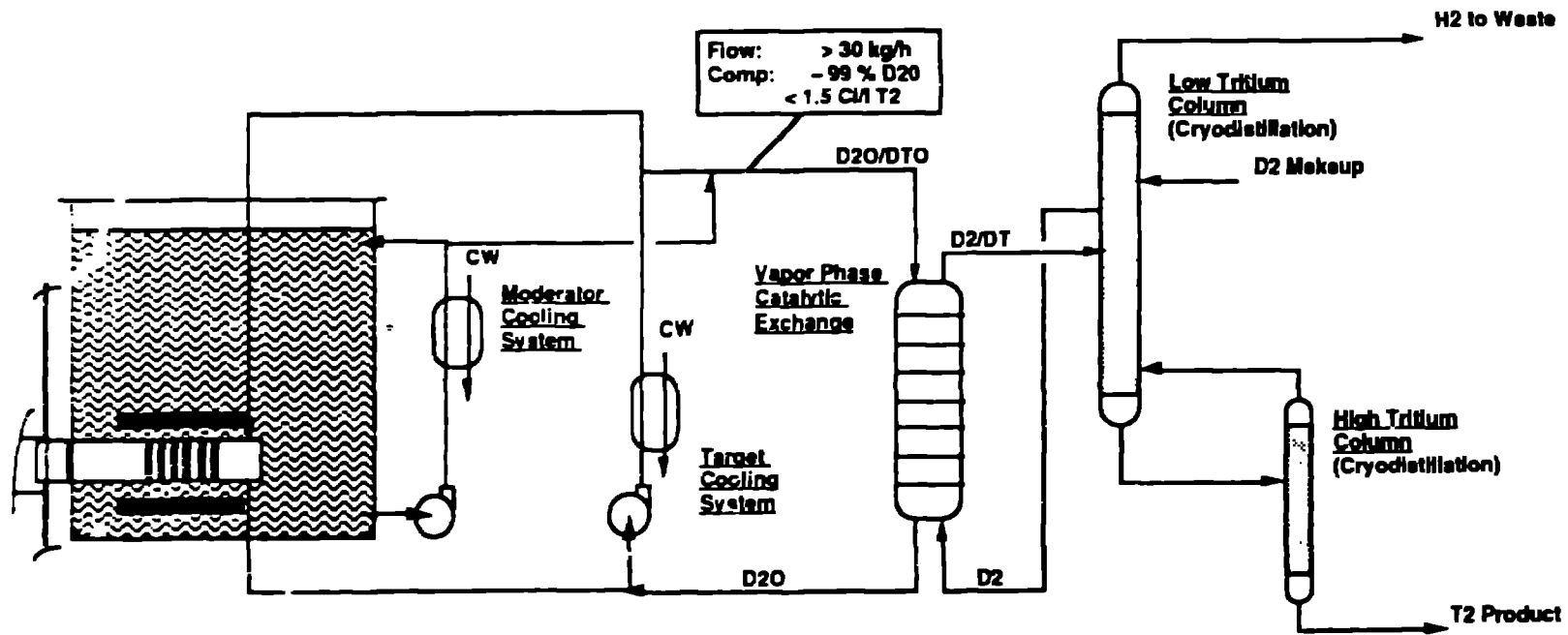

Gaseous Waste Treatment System

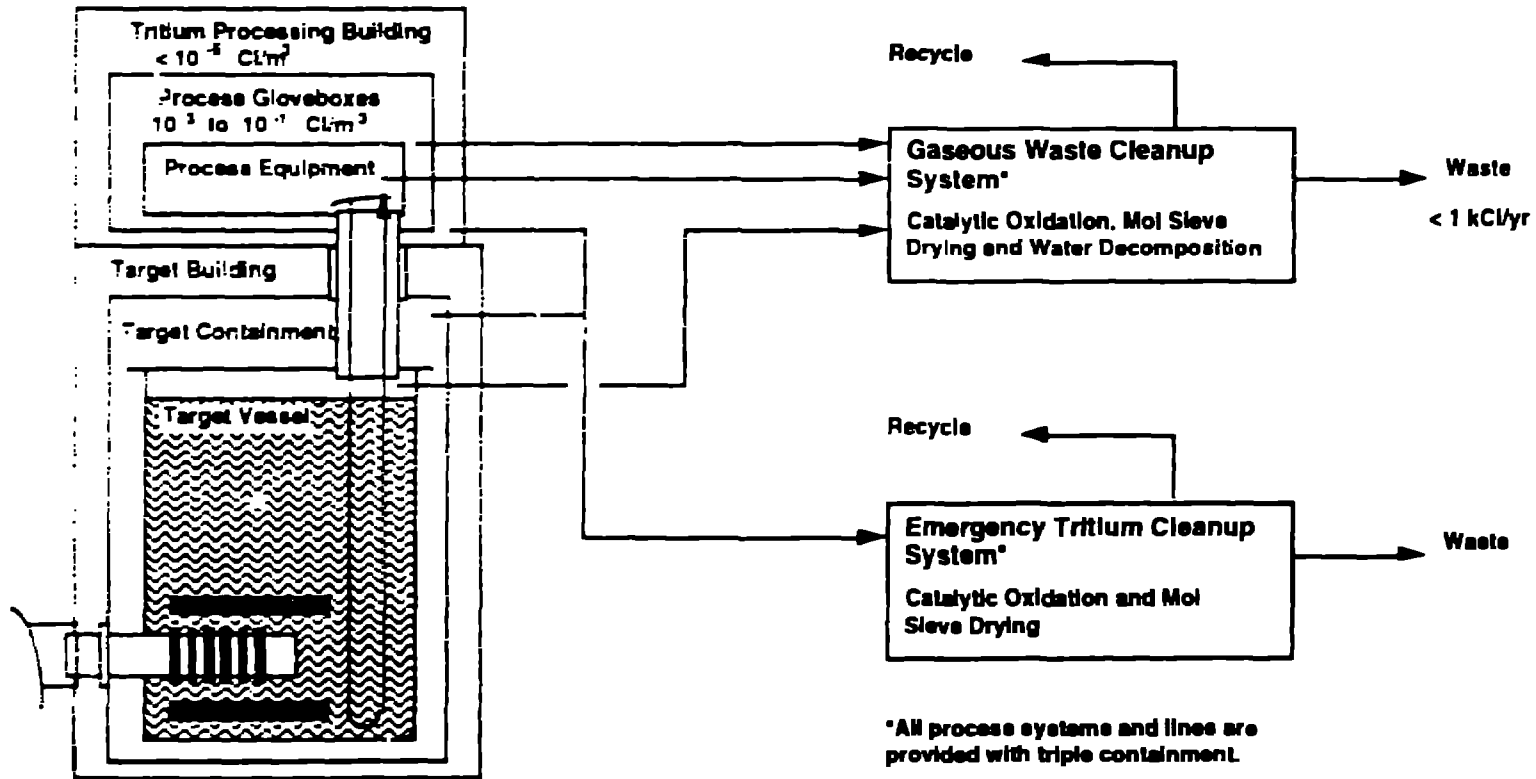

Annual Tritium Releases Tritium Systems Test Assembly

Note: TSTA releases are several orders of magnitude lower than those of similar DOE Weapons Facilities

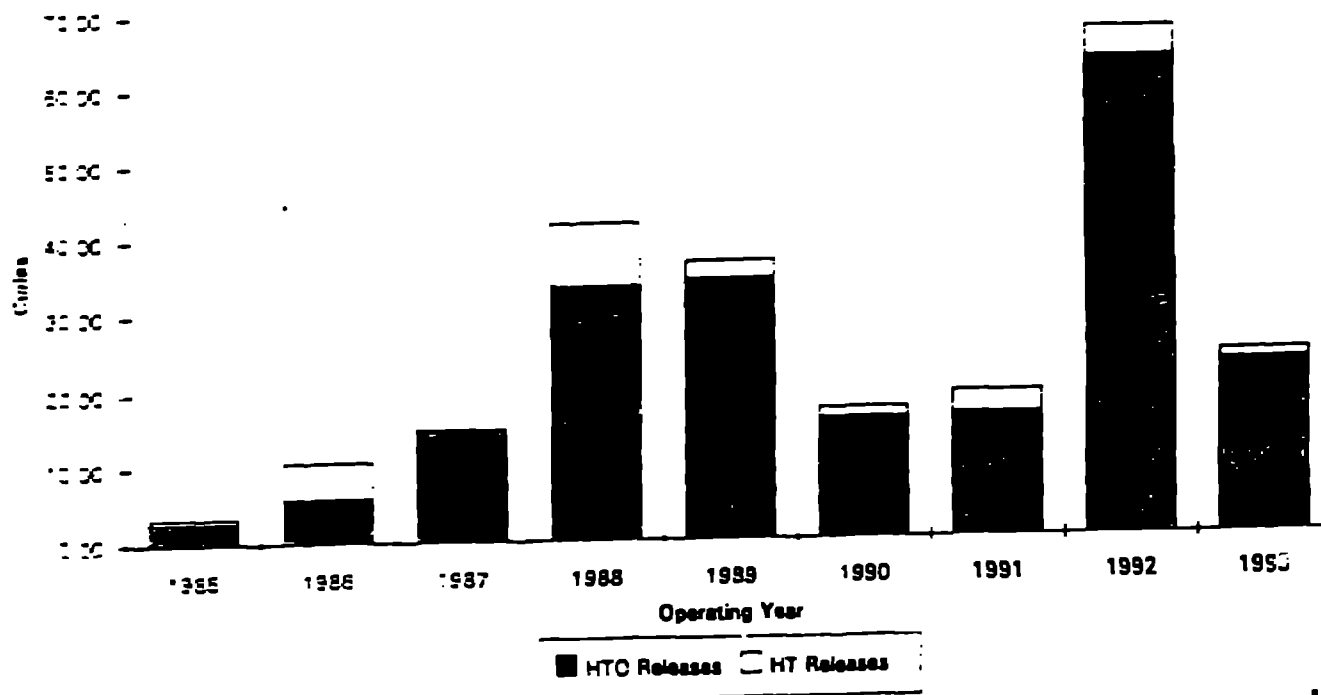

Los Alamos

Tritium Process (Support Systems) Technology

Measurement & Control

- Computer-based, Industrial control architecture.
- Fail-to-safe configuration design.
- Redundant safety systems.

Process Building

- Tritium areas designed for zone confinement.
- "Hot" shops and storage areas.
- Redundant monitoring in tritium operating areas.

Ventilation

- Tritium areas maintained at negative pressure.
- Zoned for isolation if contaminated.

Services

- Redundant power and gas supplies to key systems
- In-house backup for critical systems.
- Analytical Laboratory with Raman and mass spectrometer systems.

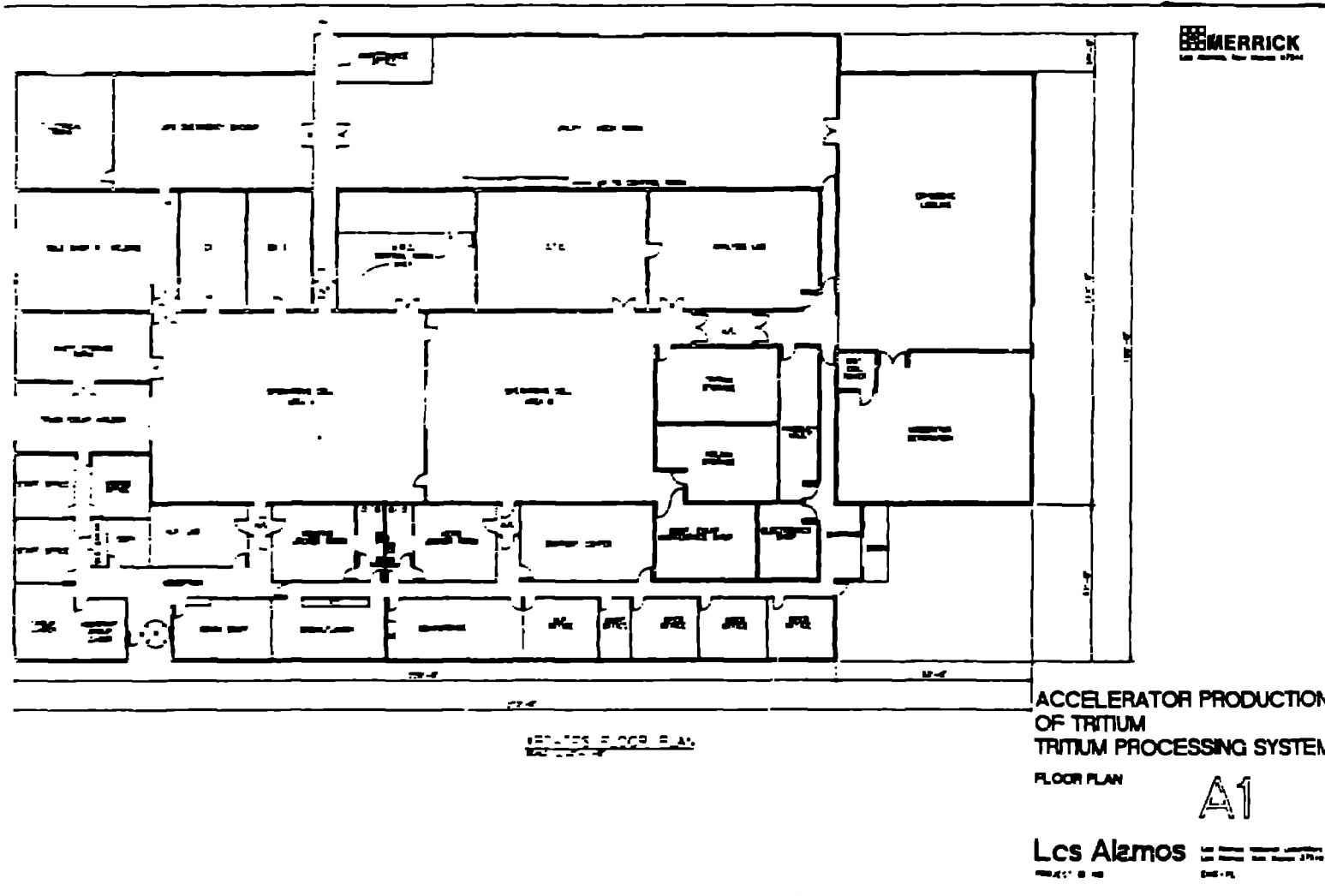

Summary

- Tritium processing systems will utilize well established, demonstrated technology.
- Safety and environmental features will be significantly improved with respect to current tritium systems.

FY 94 Design Tasks (Proposed)

- **Pre Conceptual Design completion**
 - **Heavy Water Detritiation**
 - **Instrumentation and Control**
 - **Pipe and Instrument Diagrams**
 - **Process Layout Studies**

- **Tasks deferred as a result of funding cutbacks.**

- **Completion needed to verify design concept and to serve as basis for cost estimation.**

- **Prepare "Budget Grade" cost estimate.**

APT Experiments Status

Introduction

Paul Lisowski

Physics Division

Los Alamos National Laboratory

Quarterly Status Review

June 7, 1993

Outline

- **Introduction**
- **Source Term Experiment** **Paul Lisowski**
- **Materials Safety Experiments**

- **Thermal Hydraulics Tests** **Mike Cappiello**

APT Target/Blanket/Experiment Task Objectives

- **Meet 3/8 goal quantity at 75% plant factor with 1000 MeV 200 μ A accelerator.**
 - **Target/Blanket must have high availability, operability, and maintainability.**
- **Maximize environmental advantages of APT.**
 - **Protect personnel and environment.**
 - **Minimal radioactive toxic and mixed waste.**
 - **Quantify as much as possible those advantages.**
- **Single Target/Blanket module.**
 - **Two module system, with a second as spare or in maintenance.**
- **Utilize existing technology.**
 - **Choose proven equipment and materials where possible.**
- **Incorporate safety by design.**

APT Confirmatory Experiments Address Key Issues

Materials Experiments

High neutron and proton fluences dictate careful material choices in design.

Experiments aid in materials selection and connect proton and spallation neutron data base to fission neutron data base.

Source Term Experiment

Major advantage of APT is low environmental impact.

Radionuclide production data will bound uncertainty in source term calculation

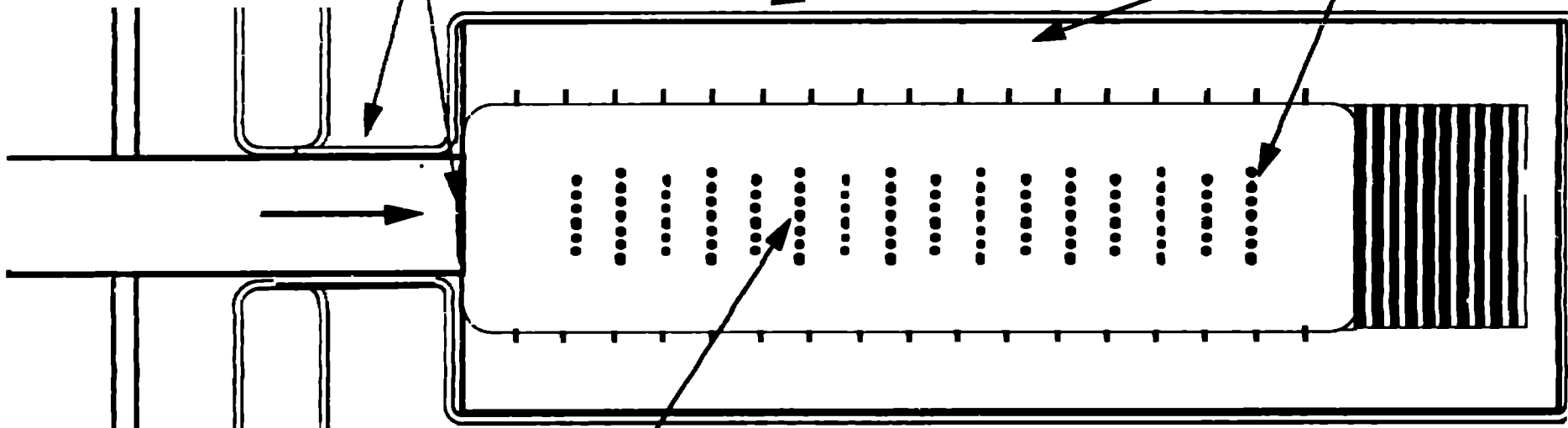

Thermal Hydraulics Experiments

Low Pressure, high flow system operates in regime where CHF data is inadequate.

TH Experiments verify adequacy of rod bundle cooling under prototypic conditions and allow tests of off-normal conditions.

APT Thermal Hydraulics Experiment

- **Experimentally verify target cooling under prototypic operating conditions.**
- **Perform full scale thermal hydraulic design verification tests.**
- **Establish damage thresholds under various accident scenarios.**
- **Identify potential improvements with respect to safety.**

APT Materials Safety Experiments

- **Provide input to mechanical engineering design on safe stress and ductility levels during and after radiation exposure.**
- **Compare mechanical property response after radiation exposure for Medium energy protons and spallation neutrons in order to determine extrapolation limits from fission neutron irradiated material.**
- **Investigate the role of transmutation-generated impurities on possible early-fracture mechanisms.**
- **Identify potential improvements with respect to safety.**

APT Source Term Experiment

- **Measure radionuclide production for thick targets of W and Pb in order to benchmark calculations and bound the source term and total radioactivity calculations.**
- **Collaborate with BNL in measurements at the AGS in 1993.**

Source Term Experiment

Presented by:
Paul Lisowski,
Los Alamos National Laboratory

Collaborators:

G. Butler	A. Gavron
M. Fowler	J. King
R. Gritz	J. Koster
J. Wilhelmy	P. Lisowski
M. Yates	D. Mayo
W. Wilson	R. Nelson
J. Ullmann	C. Zoeller

Outline

- **Motivation for Experiment**
- **Experimental Procedure**
- **Status**

Motivation for Experiment

- **Measure radionuclide production in target materials (Tungsten and Lead)**
 - Quantify radionuclides produced for safety and engineering
 - Set bounds on calculated “source term”
 - Study short half-life isotopes that may contribute to decay heat
- **Test our ability to calculate radionuclide production**
 - Must understand production over wide energy range
 - No experimental data exists for thick tungsten targets (A principle element in Los Alamos design)

Calculation of Radionuclide Yield

- **Cascade Models**
 - Best nuclear physics
 - Monte-Carlo model
 - Gross nuclear properties well predicted
 - Yield of individual radionuclides uncertain by factors of 2 to 3 in best cases
- **Secondary production and transport complicated**
- **Few experiments on “thick targets”**
(SNQ data at 600,1100 MeV on lead)

Calculational Questions

- **Production of isotopes for p+A as a function of incoming proton energy.**
- **Production of secondary particles (primarily neutrons) in the process.**
- **Transport of the secondaries in the bulk target assembly.**
- **Interaction of secondaries with the target material.**

- **Needed “systems test” - thick target experiment to test our ability to integrate all elements of this complex problem**

Overview of Experiment

- **Use thick targets of ^{Nat} Pb, ^{Nat} W** -
Sample at various locations in target with 0.020" and 0.040" thick foils
- **Irradiate at 800 MeV**
 - Few seconds, to study short half lives
 - 1 hr, 3 hr irradiation to study longer-lived isotopes
- **Identify isotopes by their gamma ray decay spectrum**
 - Each isotope emits several characteristic gamma-rays
 - Use high resolution Ge detectors
 - Measure spectrum several times to determine half-life
 - Foils from short irradiations counted at WNR with 5 Ge detectors
- **Foils from long irradiations counted at Nuclear Chemistry facility**
 - Automated foil changing detectors

Tungsten Irradiation Assembly

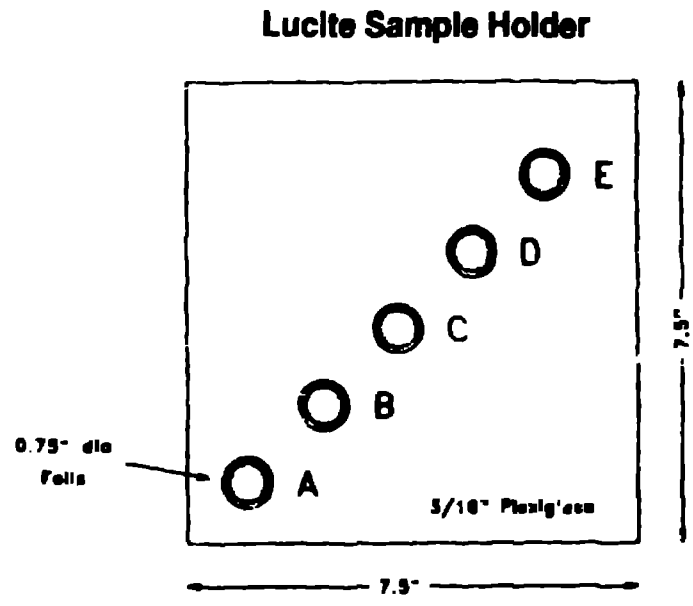
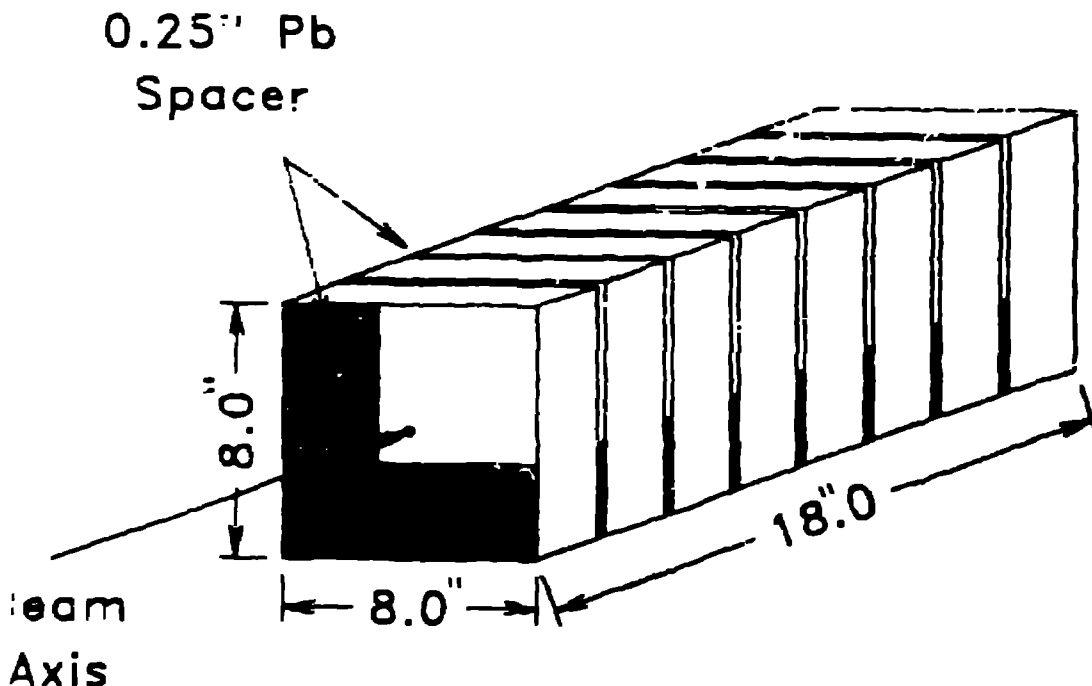

Tungsten samples were placed at locations 'A - E.' 'A' was on-beam-axis.

Summary of APT Tungsten Irradiations

- **14 “Short” Irradiations**
 - 5 foils each, foils counted immediately at WNR
 - 500 pulses (2 sec) to 100,000 pulses (156 sec)
 - 1.5×10^{11} protons to 3.45×10^{14} protons
- **1 medium irradiation : 1.1×10^6 pulses in 3900 sec**
 - 3.5×10^{14} protons
 - 24 foils counted at Nuclear Chemistry Facility
- **1 long irradiation : 4.4×10^6 pulses in 21945 sec**
 - 1.3×10^{15} protons
 - 30 foils, counted at Nuclear Chemistry Facility

Lead Irradiation Assembly

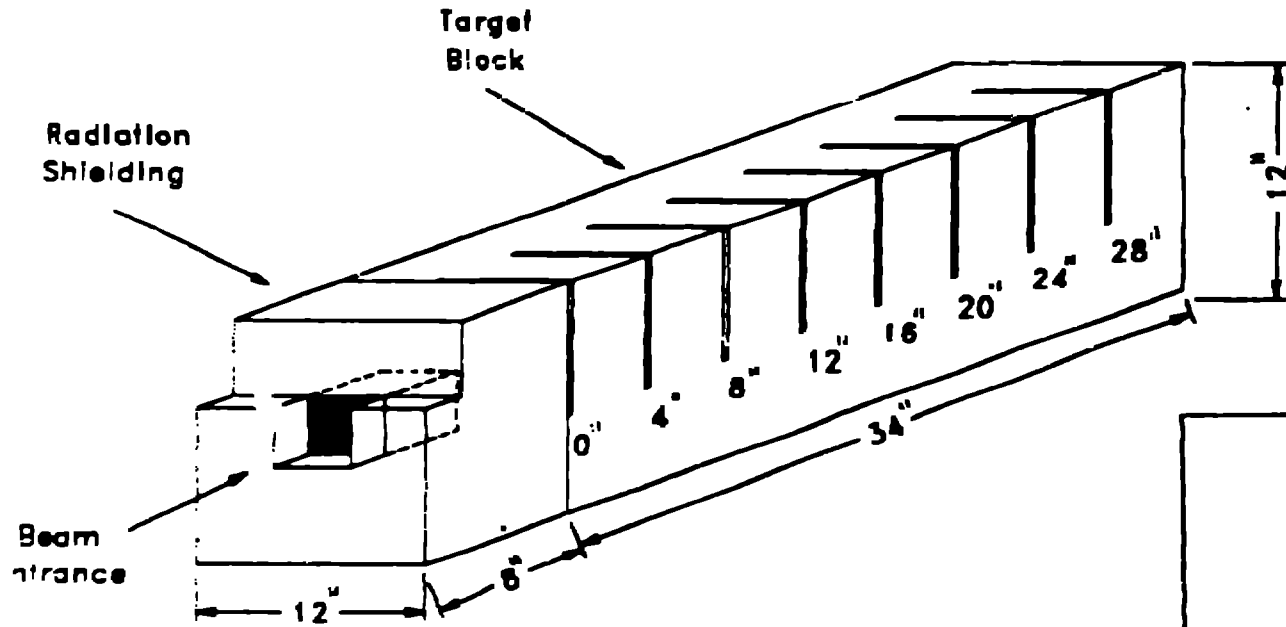

Lucite Sample Holder

Samples were placed at locations 'A - E.' 'A' was on-beam-axis.

0.75" dia
Folts

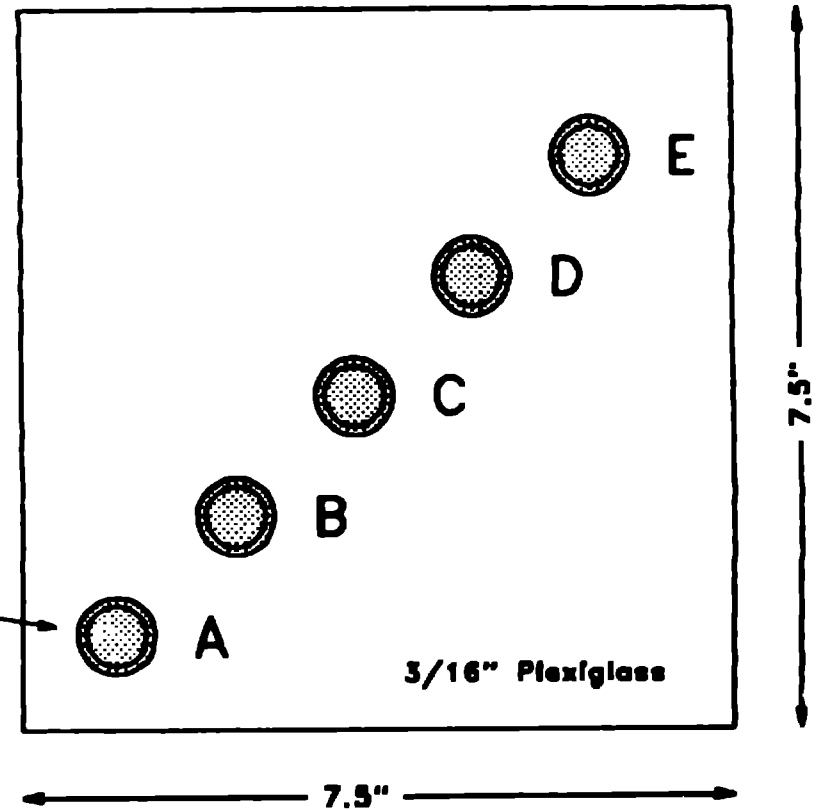

Summary of APT Lead Irradiations

- **9 “Short” Irradiations**
 - 5 foils each, counted immediately at WNR
 - 200 to 200,000 beam pulses, 3 sec to 367 sec
 - 6×10^{11} protons to 6×10^{13} protons
- **1 “medium” irradiation**
 - 1×10^6 beam pulses in 1352 seconds
 - 3×10^{14} protons
 - 24 foils, counted at Nuclear Chemistry Facility
- **1 “long” irradiation: 5.5×10^6 beam pulses in 4265 seconds**
 - 1.6×10^{15} protons
 - 29 foils, counted at Nuclear Chemistry Facility

Typical Results

- Spectrum from tungsten irradiation designed to get short half-life activity
- First results ever for isotopes with $t_{1/2} < 30$ minutes.
- Data at 50-minutes after exposure, 3-minute count

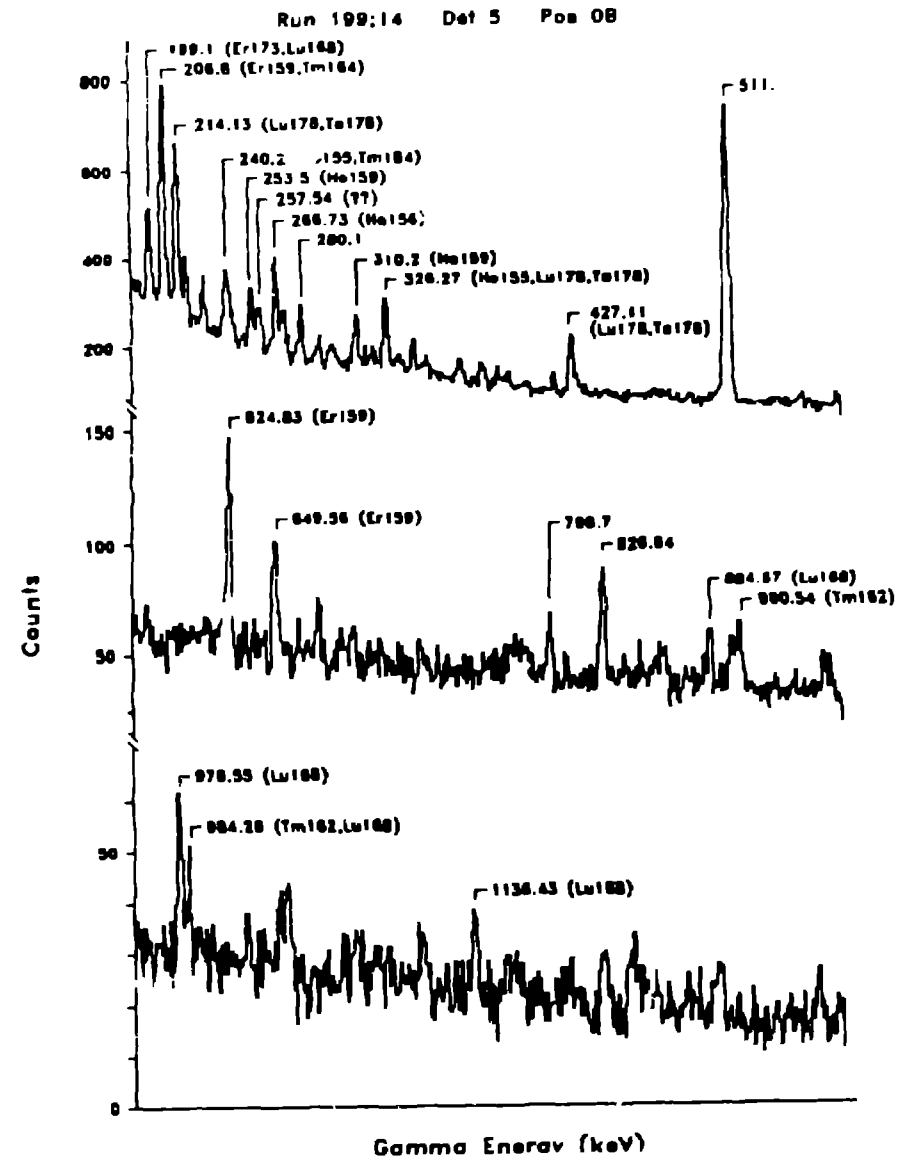

Stages of Analysis

I. **Calibrations: Energy and efficiency standards traceable to NIST**

- **Energy Calibration**

Fast ADC's introduced slight non-linearity

1 part in 10000 precision required

- **Detector efficiency**

"Thick" targets have 10% transmission for low-energy gamma rays
- accurate corrections needed.

II. **Data Processing (Peak identification)**

III. **Understand complicated decay schemes to determine primary spallation products**

Summary and Status

- **Thick-target radionuclide production experiment at 800 MeV completed. Foils have been counted.**
- **Calibrations have been completed.**
- **Data processing is under way**
- **Spallation radionuclide decay library update in progress**
- **Predictions of yield completed, awaiting comparison to data.**

Materials Safety Experiments

Presented by:
Paul Lisowski,
Los Alamos National Laboratory

Walt Sommer, Los Alamos National Laboratory, P.I.

Collaborators:

J. Stubbins, Univ. of Illinois

P. Hamilton, Pacific Northwest Laboratories

S. Bourcier, Sandia National Laboratory

C. Cappiello, Los Alamos National Laboratory

M. Cappiello, Los Alamos National Laboratory

E. Zimmermann, Los Alamos National Laboratory

E. Farnum, Los Alamos National Laboratory

M. Borden, Los Alamos National Laboratory

APT Quarterly Review
June 7, 1993

LAMPF Experiments are Needed to Connect Low and High Energy Material Damage Results

Thermal Neutrons

1 GeV protons

Fast Neutrons

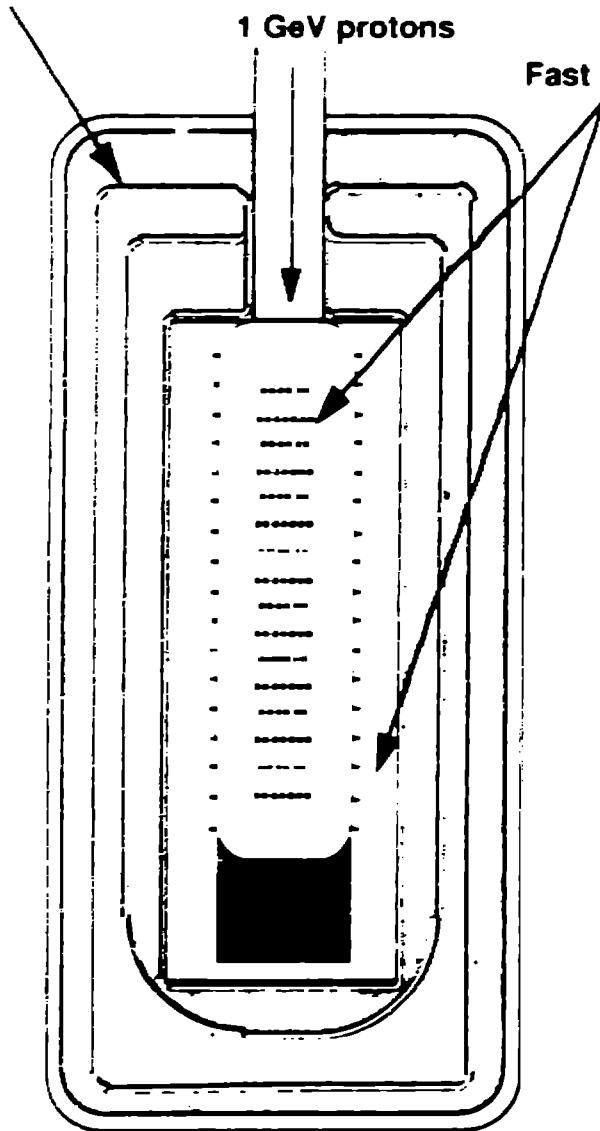

Neutron Flux Integrals Normalized at 1 MeV

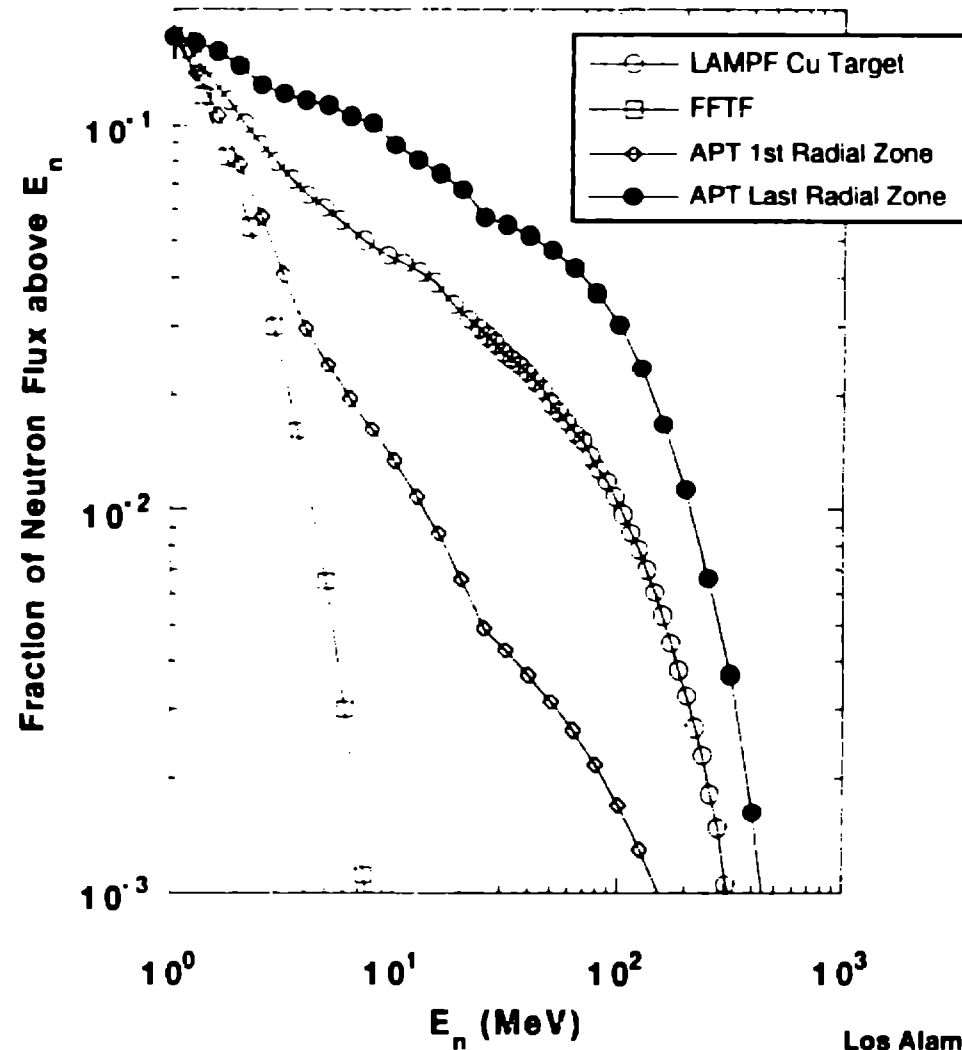

Los Alamos

RATIONALE FOR AND PURPOSE OF APT MATERIALS Safety Study

- **Aluminum Alloys offer high efficiency relative to other structural materials due to a low thermal neutron absorption cross section. They have been considered prime candidates for all facilities where high thermal neutron fluxes are required.**
- **A limited experience base for the use of aluminum Alloys exists for APT-Relevant proton and neutron spectra [LAMPF, LANSCE, SIN]; Some Alloys have performed well.**
- **Extrapolation to APT target and blanket conditions involves uncertainties as demonstrated by differences seen between performance in fission reactor environments and in an 800 MeV proton beam.**
- **Using material already irradiated, or scheduled to be irradiated, this test plan was designed to remove uncertainties associated with the use of aluminum alloys for APT, to develop a more sound data base and to establish safe stress levels for design.**

Testing Methods

- **Microhardness - Los Alamos**
- **Tensile Properties - University of Illinois**
- **Disc-Shear tests - Battelle - Pacific Northwest Laboratories**
- **Scanning Electron Microscopy - Sandia National Laboratory**

Preliminary Test Results

- **Samples Irradiated with 800 MeV protons at 10^{20} - 10^{21}**
 - AlMgSi and AlMg alloys at $> 200^{\circ}\text{C}$ - loss of tensile strength $\sim 10^{20}/\text{cm}^2$
 - AlMgSi and AlMg alloys at $\sim 50^{\circ}\text{C}$ - little effect on mechanical properties $\sim 2 \times 10^{21}/\text{cm}^2$
 - AlCu 2219 alloy at $\sim 120^{\circ}\text{C}$ - Microhardness tests show little effect after a fluence of $\sim 10^{21}/\text{cm}^2$.

- **Irradiated with spallation neutrons at $2 - 5 \times 10^{20}/\text{cm}^2$**
 - AlMgSi and AlMg alloys at $90 - 120^{\circ}\text{C}$ - little effect on mechanical properties

Long Range Materials Test Plan

- **Features:**
 - Prototypic radiation environment
 - Prototypic stress states including cyclic variations
 - Prototypic corrosion conditions
 - Uses materials from controlled lots
- **Facilities: LAMPF AGS HFBR HFIR ACRR ATR EBR II**
- **Special tests - materials already on hand**
 - Irradiated properties of W and Alloys
 - Irradiated at LAMPF in 1992 to $> 10^{21}/\text{cm}^2$
 - Test mechanical properties with microhardness
 - Determine product release as a function of temperature
 - Irradiated properties on beam-entry windows
 - LAMPF Inconel 718 windows
 - PSI/SIN Fe-10.5% Cr windows

Experiment Status

- **Testing is complete**
- **Topical Report has been initiated**
- **Scanning electron microscopy at SNL continues**

**APT
DESIGN REVIEW**

**APT THERMAL HYDRAULIC
EXPERIMENT**

PRESENTED BY

MIKE CAPPIELLO

APT THERMAL HYDRAULIC EXPERIMENT

OBJECTIVE:

- **VERIFY ADEQUACY OF COOLING TARGET UNDER PROTOTYPIC CONDITIONS.**
- **PRESSURE , TEMPERATURE, FLOW.**
- **CRITICAL HEAT FLUX (CHF) UNDER LOW PRESSURE, HIGH VELOCITY, HIGH L/D COND.**
- **LOSS OF PRESS/TEMP/FLOW RESPONSE/LIMITS**

APT THERMAL HYDRAULIC EXPERIMENT

RATIONALE:

- SCARCITY OF CHF DATA IN 0.1 TO 2.0 KW/SQ.CM. RANGE.
- SCARCITY OF CHF DATA IN 50 TO 600 L/D RANGE.
- CHF CORRELATIONS FOR SUB-COOLED FLOW HAVE ERROR BARS TO $\pm 50\%$.
- LITTLE WORK HAS BEEN DONE ON PARALLEL CHANNEL AND INTERCONNECTED CHANNEL INSTABILITIES .

TESTING OF PROTOTYPIC CONFIGURATION, TEMPERATURE, PRESSURE, MASS FLOW IS NECESSARY FOR DESIGN ASSURANCE.

APT THERMAL HYDRAULIC EXPERIMENT

EXPERIMENTAL METHODS:

- **COLD FLOW TEST.**
- **ELECTRICALLY HEATED
HOT TEST.**

APT THERMAL HYDRAULIC EXPERIMENT (COLD TEST)

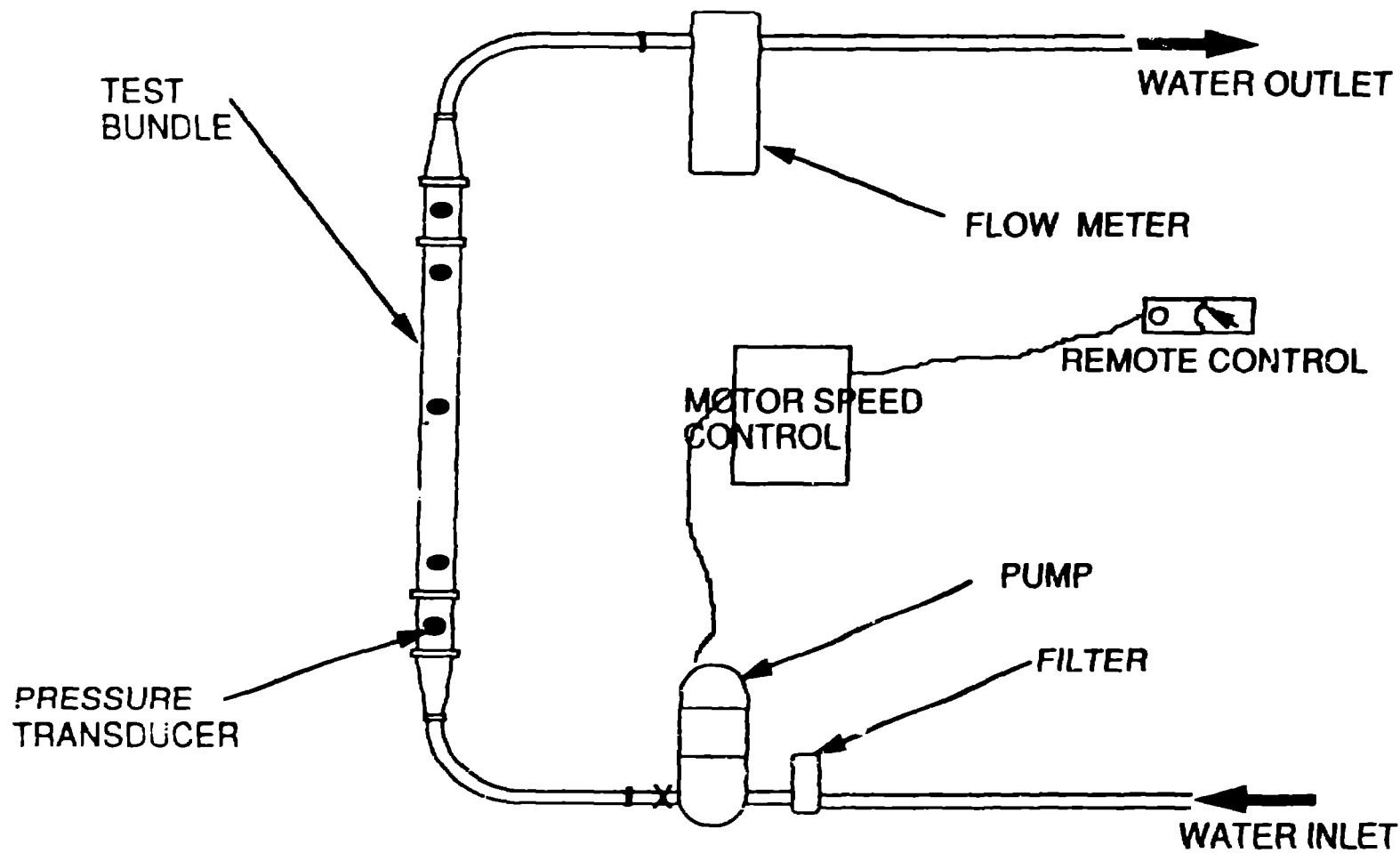

Thermal Hydraulic Experiment

Los Alamos

APT THERMAL HYDRAULIC EXPERIMENT (COLD TEST)

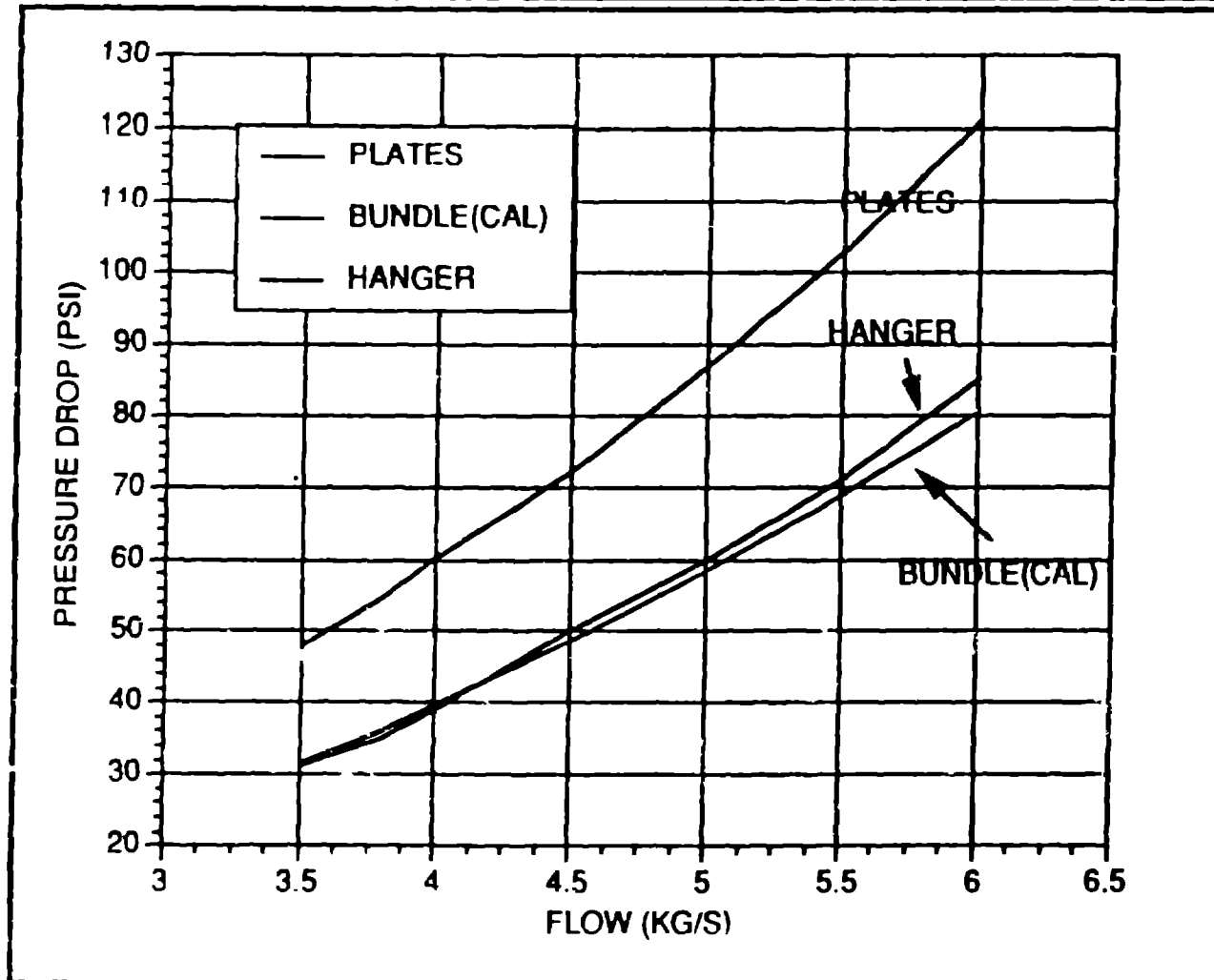

APT THERMAL HYDRAULIC EXPERIMENT (HOT TEST)

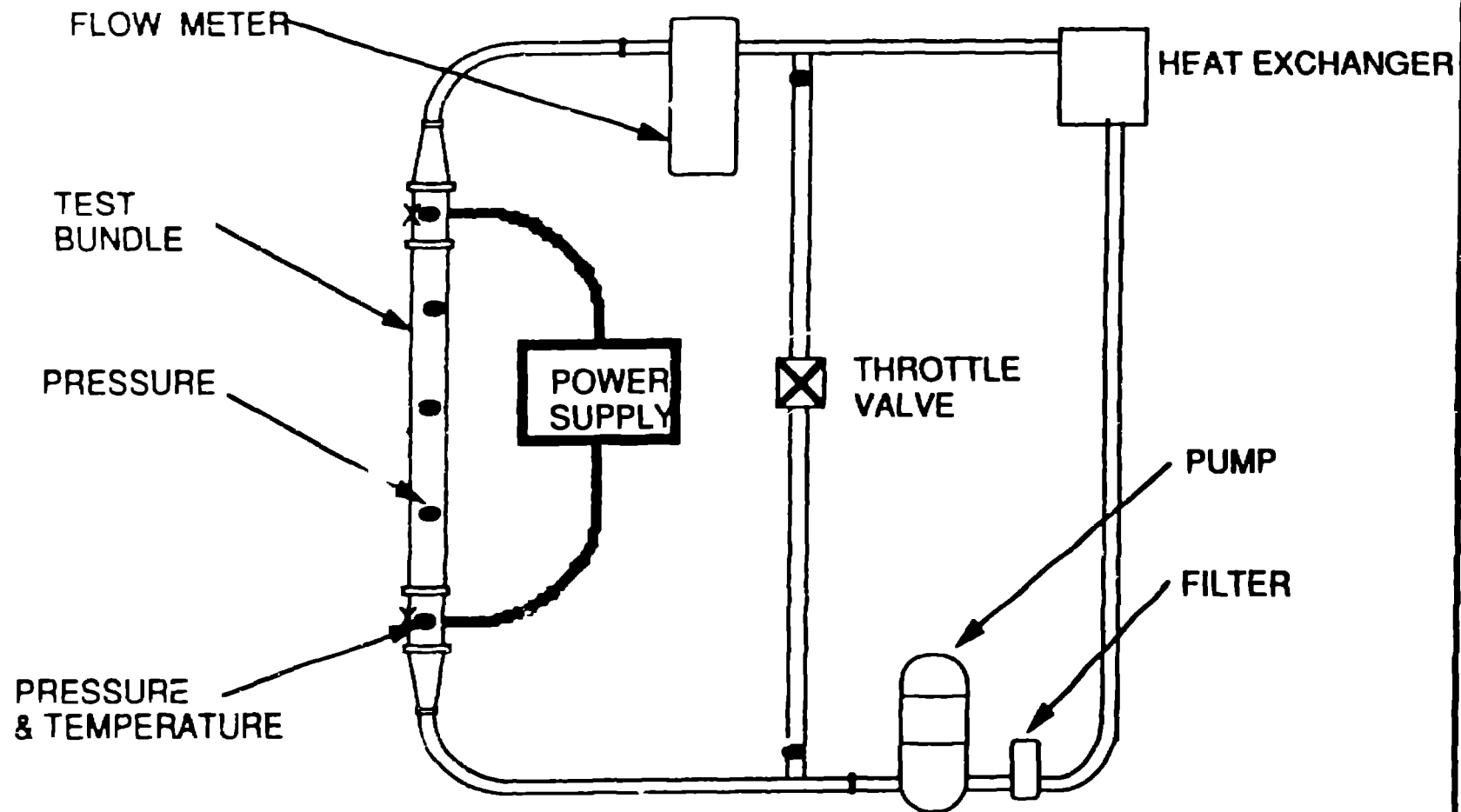

Thermal Hydraulic Experiment

Los Alamos

APT THERMAL HYDRAULIC EXPERIMENT (HOT TEST)

- 1. STEADY STATE FULL POWER TESTS.**
 - **HEAT TRANSFER COEFFICIENT.**
 - **BUNDLE PRESSURE DROP.**
- 2. CRITICAL HEAT FLUX TEST.**
- 3. LOSS OF HEAT SINK TRANSIENT (T-IN INCREASE)**
- 4. LOSS OF PUMP ACCIDENT (FLOW REDUCTION, BEAM TRIP).**
- 5. LOSS OF POWER ACCIDENT (LOSS OF FLOW, BEAM TRIP, LOSS OF PRESSURE).**

Initial tests with 7-pin bundle, subsequent test with 19 pin bundle.

APT THERMAL HYDRAULIC EXPERIMENT TEST FACILITIES

- **2.5 MW D.C. POWER SUPPLY.**
- **RECTIFIED A.C. & RF POWER SUPPLIES
AVAILABLE.**
- **POWER DISTRIBUTION SYSTEM IN PLACE TO
TEST CELL.**
- **DEDICATED 5 MW COOLING TOWER.**
- **8 MW TOTAL POWER ON SITE (TA-46).**
- **DATA ACQUISITION SYSTEM IN PLACE.**
- **HIGH BAY CONTAINMENT VESSEL AREA
AVAILABLE**

APT THERMAL HYDRAULIC EXPERIMENT

HOT TEST

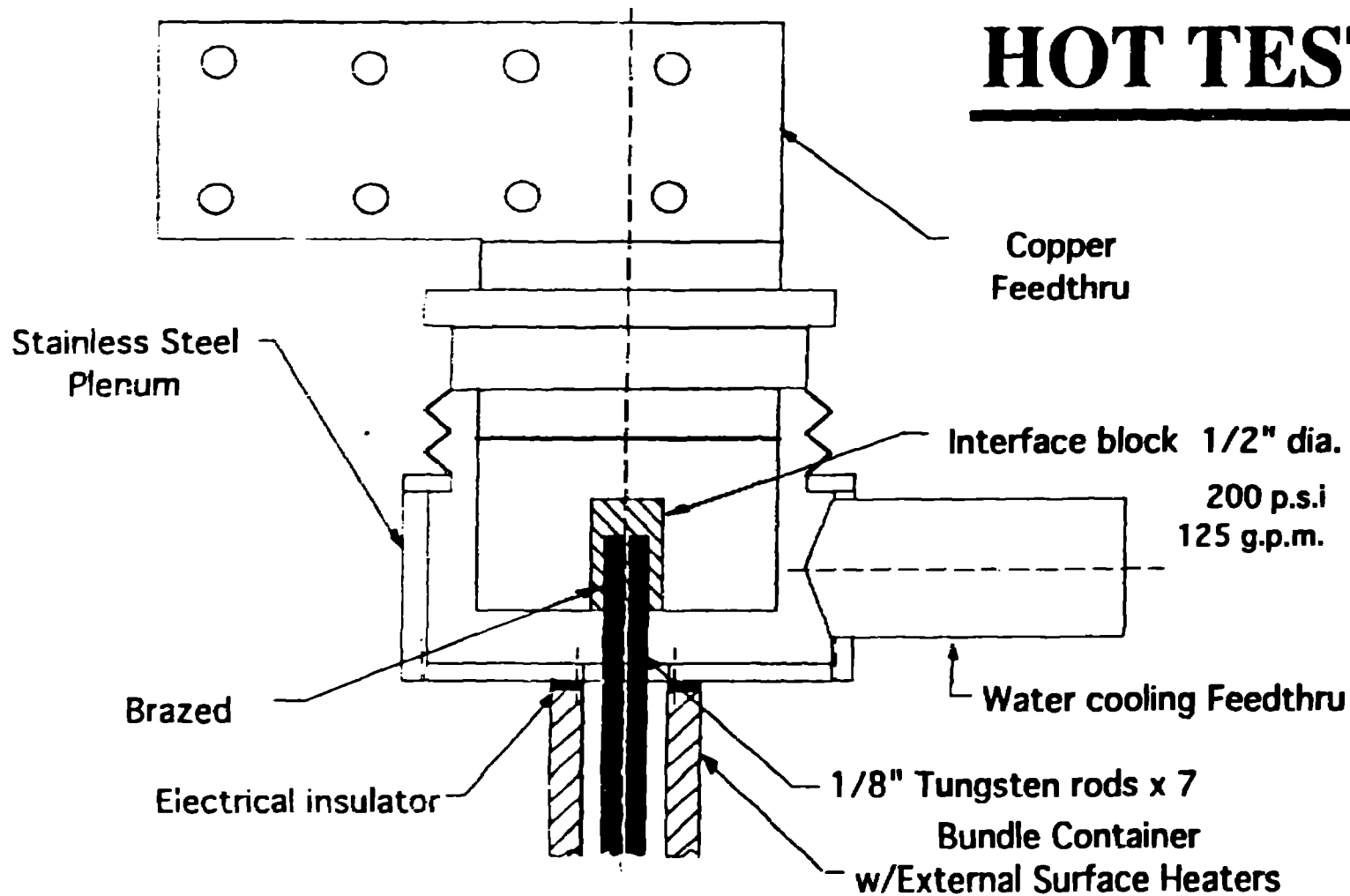

Thermal Hydraulic Experiment

Los Alamos

APT THERMAL HYDRAULIC EXPERIMENT

TEST STATUS:

- **COLD FLOW TEST COMPLETED.**
- **HOT TEST SYSTEM DESIGN COMPLETE.**
- **1.25 MW POWER SUPPLY AND DISTRIBUTION NETWORK SWITCHING OPERATION VERIFIED.**
- **MOTOR GENERATOR ENERGIZED, VOLTAGE APPLIED TO DUMMY LOAD.**
- **7-PIN TEST BUNDLE BEING INSTALLED.**

APT Accelerator Design Overview

George Lawrence

Accelerator Technology Division

Los Alamos National Laboratory

DOE/DP Quarterly Review

June 7-8, 1993

Los Alamos APT Team

Accelerator Design Agenda

Design overview	G. Lawrence	LANL	15
Accelerator physics	G. Lawrence	LANL	20
Engineering	J. Erickson	Grumman	20
RF power	M. Lynch	LANL	20
Power conditioning	G. Schofield	Maxwell	10
Beam transport, beam stop	R. Kraus	LANL	25
Operations, safety, etc.	G. Lawrence	LANL	25
Summary	G. Lawrence	LANL	05

LANL APT Accelerator Design Team

Jim Billen

Bob Garnett

Subrata Nath

George Neuschaefer

Dale Schrage

Lloyd Young

Tom Wangler

Barbara Blind

Doug Gilpatrick

Bob Kraus

Fillipo Neri

Dan Rusthoi

Bob Shafer

Nathan Bultman

Larry Carlisle

Don Liska

Greg MaCauley

Mike Lynch

Amy Regan

Paul Tallerico

Chris Ziomek

Jean Browman

Rob Ryne

Stuart Bowling

Andy Kozubal

Joe Sherman

Ralph Stevens

Bob Hardekopf

George Lawrence

Bob Jameson

Dick Woods

Industry Partners

Grumman Aerospace (Linac Engineering)

Steve Ellis

Mike Kornely

John Rathke

John Erickson

John Moeller

Pete Smith

Tom Ily

Maxwell/ABB/Litton (Power Systems Design)

George Schofield (Maxwell)

Willie Wong (ABB)

Ed Chu (Maxwell)

Donald Laycock (Litton)

General Atomics (Beam Transport Engineering)

Ross Harder

John Rawls

Mike Heiberger

Outline

- **Performance requirements**
- **Reference accelerator concept**
- **Key parameter selection**
- **Beam transport concept**
- **Technology base maturity**
- **Technical issues**
- **Design status**

Linac Design Requirements

- **3/8-Goal tritium production at 75% plant factor**
- **High availability and operability**
- **Minimum life cycle cost**
- **High electrical efficiency**
- **Machine, personnel, and environment protection**

As Proton Energy Increases Different Accelerating Structures are Used

RFQ (Radiofrequency Quadrupole)
Low Energy

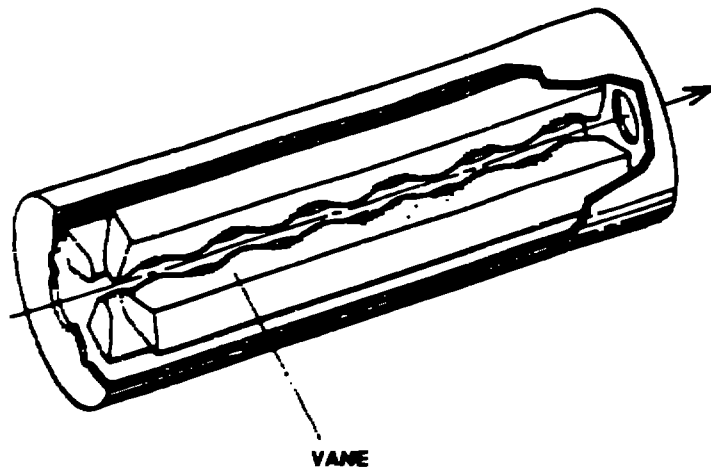

DTL (Drift-Tube Linac)
Medium Energy

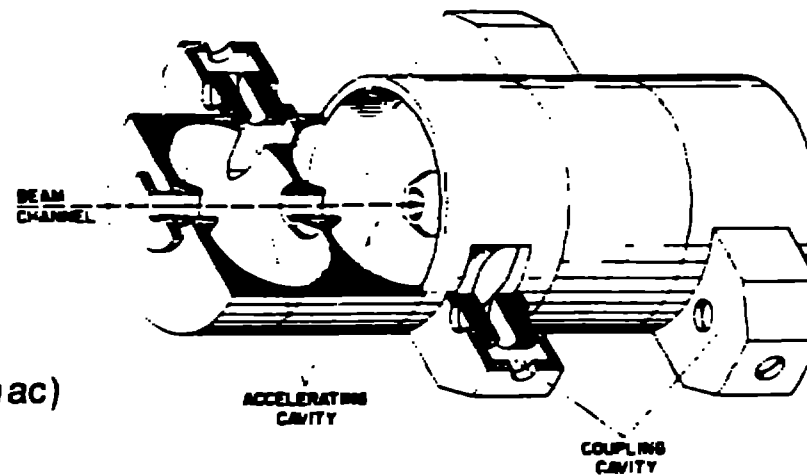
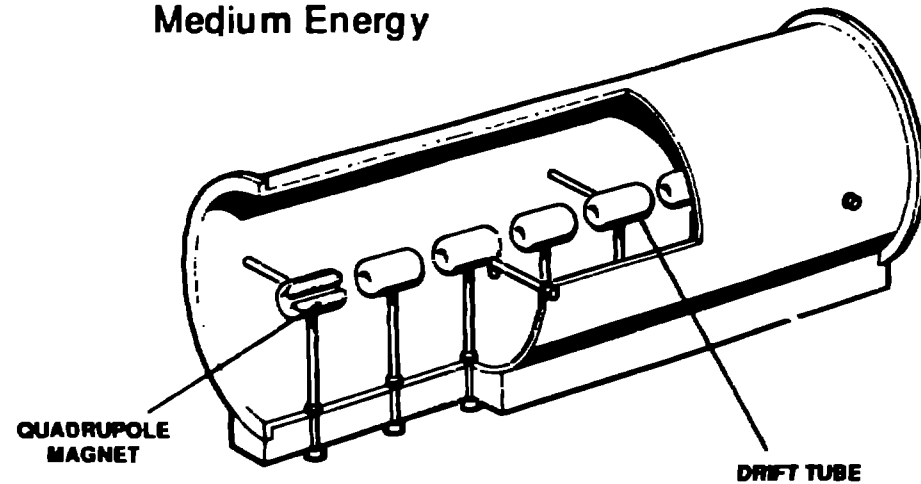

CCL (Coupled-Cavity Linac)
High Energy

Introduction to APT Accelerator Design

- **Linac design is based on conventional technology approach**
 - Room-temperature copper accelerating structures
 - Performance levels demonstrated or within technology base
- **Key parameters justified by limited cost/performance trades**
- **Conservative overall accelerator design framework**
 - Low-energy section derived from NPB/SDI technology advances
 - High-energy section based on proven LAMPF technology
 - RF power system uses CW klystrons developed for colliders
- **Linac design has evolved to stable, self-consistent solution**

Reference APT Accelerator 1000-MeV, 200-mA CW Proton Linac

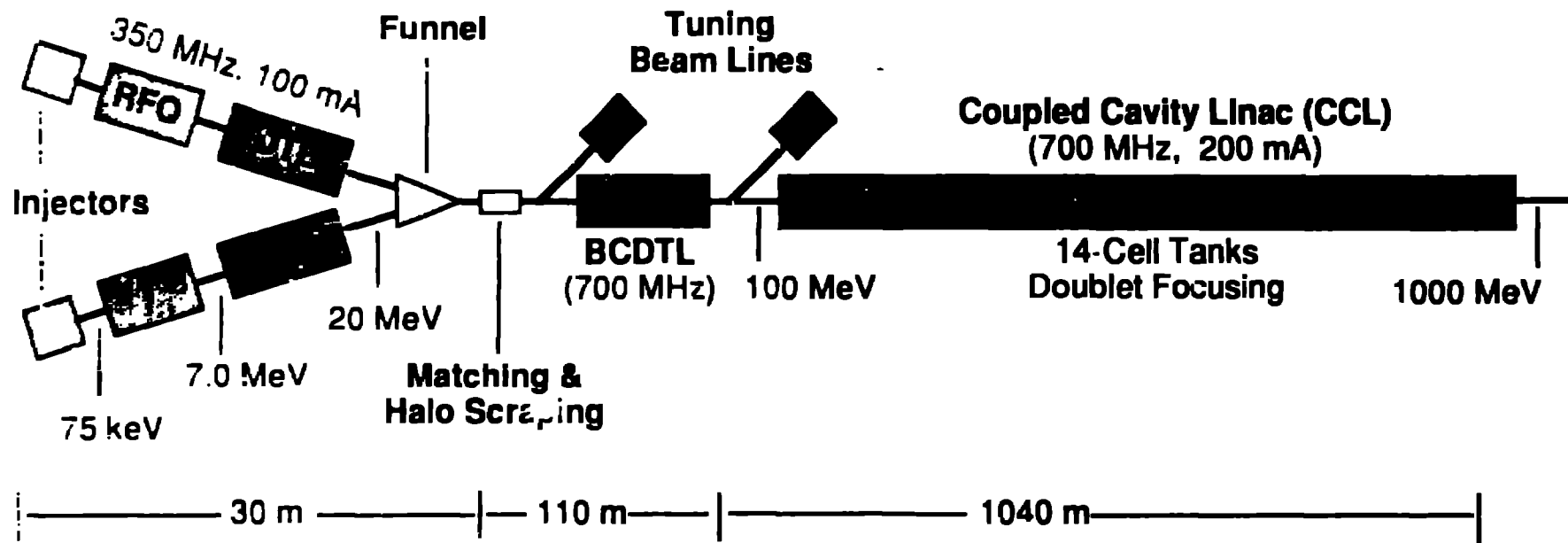

Beam power	200 MW
Total RF power to linac	254 MW
RF to beam efficiency	0.787
AC to RF efficiency	0.582
RF transport efficiency	0.950
AC to beam efficiency	0.435
AC power requirement	485 MW
Average CCL gradient	1.0 MV/m
Transverse output emittance	0.04 π cm-mrad
CCL aperture/beam-size ratio	13-26

Los Alamos
APT Team

APT Reference Accelerator Parameters (2/3/93)

	RFQ (2)	DTL (2)	BCDTL	CCL	Totals
Structure Type	4-vane	$1\beta\lambda$	$1\beta\lambda$	side-coupled	
Frequency (MHz)	350	350	700	700	
Energy (MeV)	0.075 to 7.0	7.0 to 20	20 to 100	100 to 1000	
Output Current (mA)	100	100	200	200	
Avg Gradient E_0T (MV/m)			1.0	1.00	
Struct. Gradient, E_0T (MV/m)	0 to 1.75	0.83 to 2.24	1.7, 1.5	1.50, 1.30, 1.38	
Synchronous Phase (deg)	-90 to -30	-35 to -25	-40 to -30	-30	
Shunt Impedance (M Ω /m)			23.0 to 24.3	23.0 to 37.4	
Total Length (m)	8.1	8.0	93.6	1039	1180 ^a
Tank Length (m)		2.5	0.61 to 1.27	1.29 to 2.52	
Cells per Tank	433	22 to 15	7	14	
Radial Aperture (cm)	0.235 (min)	1.0	2 to 2.25	2.5	
Aperture Beam-Size Ratio		6.5	8 to 13	13 to 26	
RF Power					
Copper (MW)	1.12x2	1.15x2	6.5	43.2	54.2
Beam (MW)	0.70x2	1.30x2	16.0	180.0	200.0
Total (MW)	1.82x2	2.45x2	22.5	223.2	254.2
Efficiency	0.385	0.530	0.711	0.806	0.787
Focusing					
Quadrupole Lattice	FD	FOFODODO	FDO	FDO	
Phase-Adv./Period (deg.)		80 to 70	80	70	
Eff. Quad. Length (cm)		5.7	5 to 6	7 to 11	
Quad. Spacing (m)		0.01 to 0.17	1.04 to 1.93	1.93 to 3.56	
Quad. Gradient (T/m)		35 to 30	49 to 57	46 to 61	
Emittance (normalized, rms)					
Transverse (\times cm-mrad)	0.02 to 0.022	0.023 to 0.025	0.031 to 0.035	0.035 to 0.038	
Longitudinal (\times MeV-deg.) ^b	0 to 0.234	0.220 to 0.235	0.275 to 0.272	0.272 to 0.309	
^a includes bunch & matching sections		^b Normalized to 350	MHz RF cycle		

Design Framework for APT Linac

- **Low energy design (< 20 MeV) emphasizes emittance control.**
- **Beam funneling at 20 MeV is a conservative design feature.**
- **High energy design (> 20 MeV) balances low beam loss & high RF efficiency.**

Basis for Selection of Key Parameters

- **Energy, Current** **1000 MeV**
 200 mA – Meets 3/8-G production requirement at minimum cost with conservative design.

- **Frequencies** **350 MHz**

 700 MHz – High enough for good emittance control;
 – Low enough for EM quads in DTL drift tubes.
 – Proven 1-MW CW klystron from industry.

 – Minimum frequency for funneled system.
 – High shunt impedance for CCL, BCDTL.
 – Reasonable-diameter structure; fabricability.
 – Klystron within familiar design space.

- **CCL gradient** **1.0 MV/m**

 – Low RF losses, with minimal thermal
 management stress in CW operation.
 – High RF-to-beam conversion efficiency.

- **CCL aperture to beam size** **13 - 26**

 – Assures $< 10^{-8}$ /m losses in CCL, while still
 providing reasonable RF efficiency.

- **CCL focusing lattice** **Doublet**

 – Provides higher aperture/beam-size ratio;
 some penalty in magnet power.

Average Current in APT Linac is 200 x LAMPF but Charge per Bunch is Only 3.4 x Greater

LAMPF

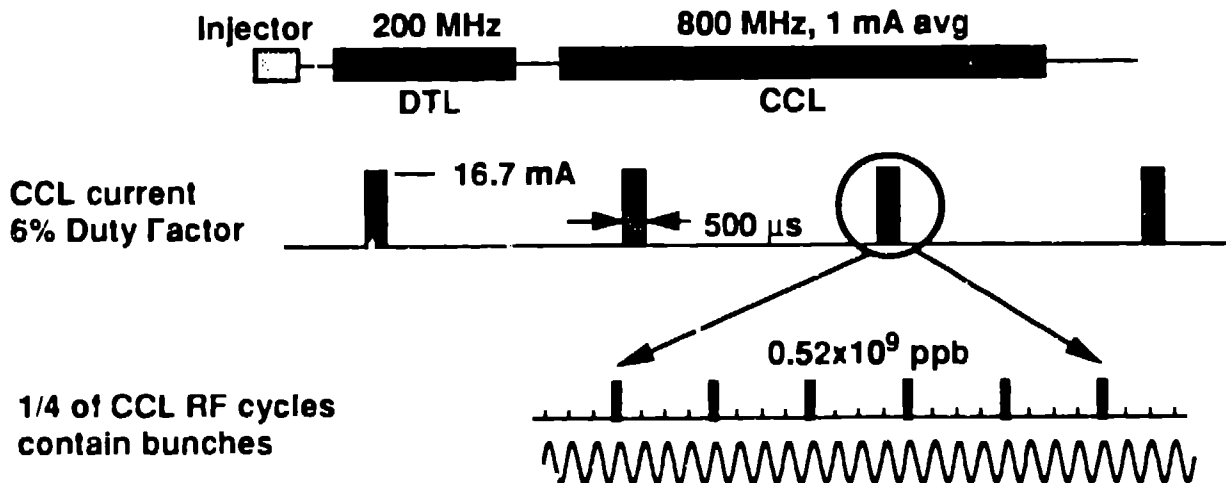

APT

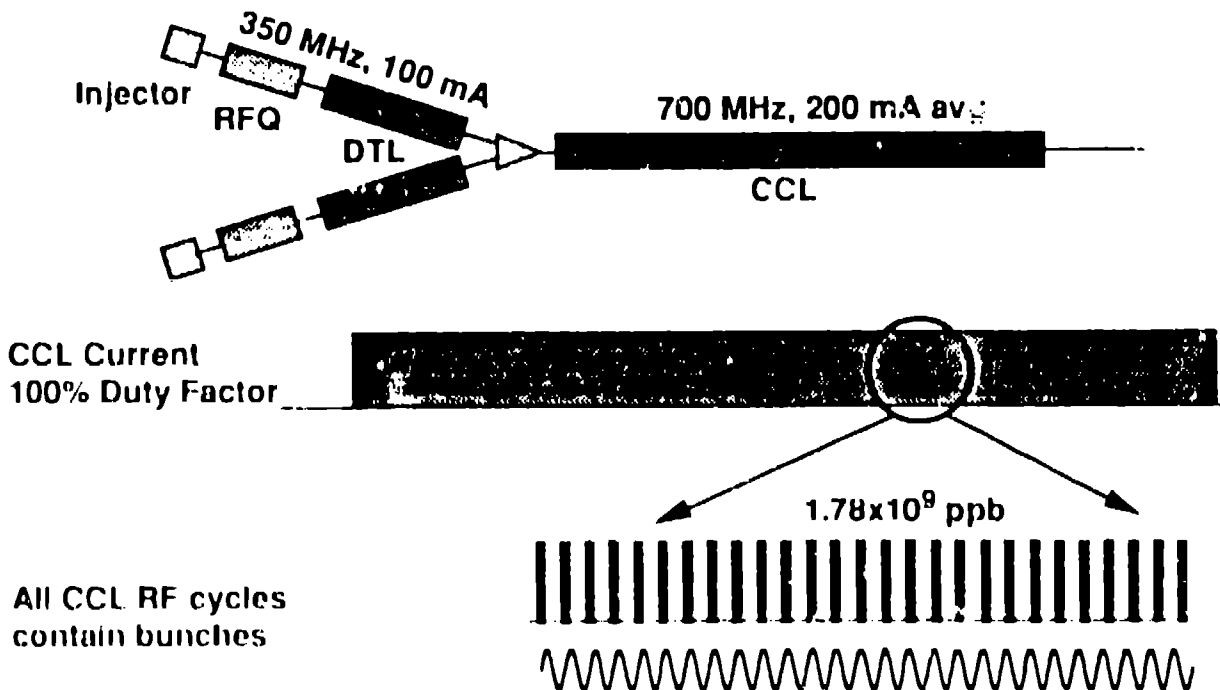

High Energy Beam Transport System

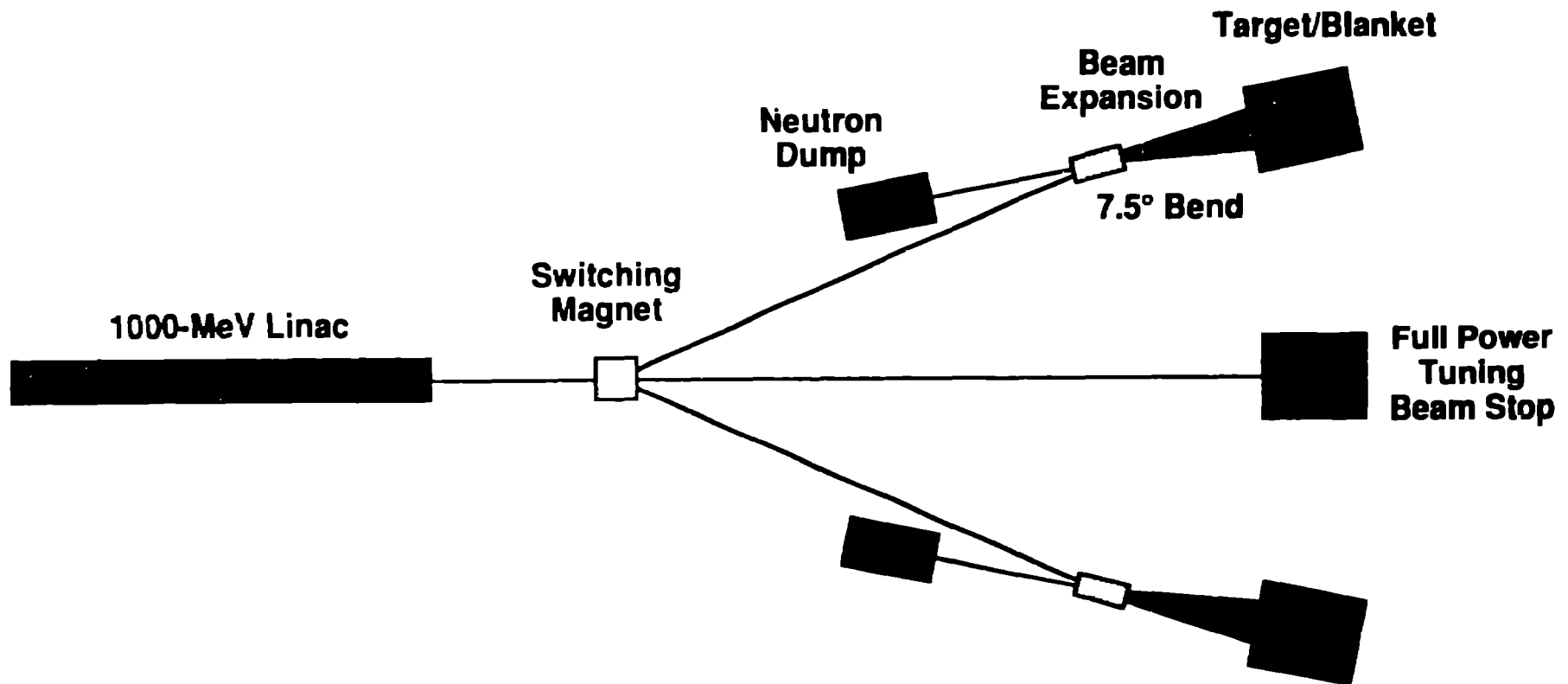

Los Alamos APT Team

Top Level Accelerator Issues

- **Beam loss in accelerator and transport system**
- **RF power system electrical efficiency**
- **RF generator-cavity-beam system control**
- **High power CW operation of RF components (windows, couplers)**
- **Transport/target interface; target protection**
- **Turn-on and fault handling; off-normal conditions**
- **Component reliability; maintenance**

Integrated system operability

Overall system availability

Cost, performance, risk tradeoff

Demonstrated Accelerator-Technology Base

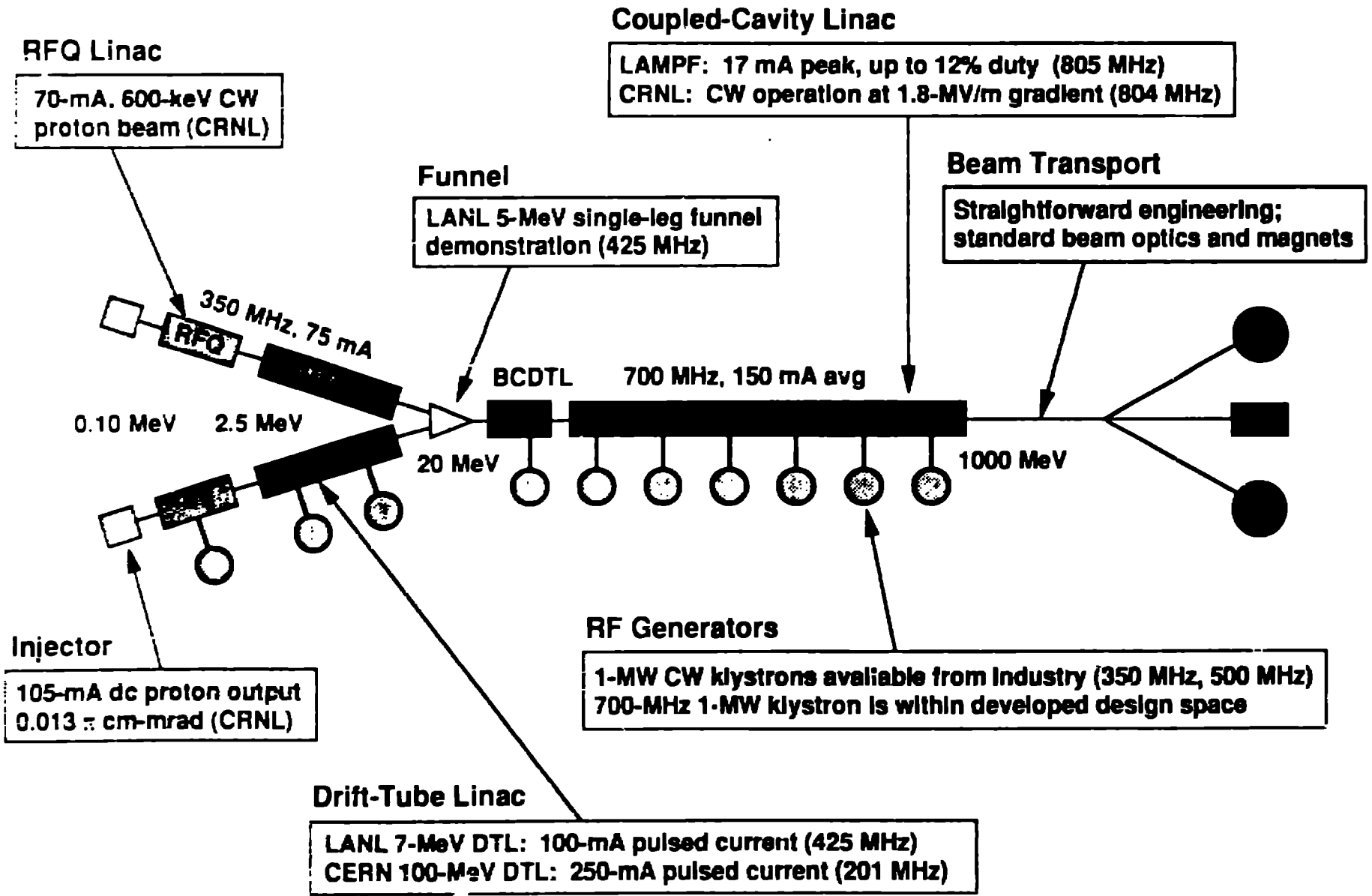

Design Summary

- **Linac, HEBT architecture and parameters frozen**
- **First-order physics design complete**
- **End-to-end beam simulations run**
- **Engineering design to PDR stage**
- **RF module design established**
- **Power system concept established**
- **Tunnel and infrastructure concepts outlined**
- **Initial exploration of operations issues**
- **Shielding and air activation estimates made**

Accelerator Physics Design

George Lawrence

Accelerator Technology Division

Los Alamos National Laboratory

DOE/DP Quarterly Review

June 7-8, 1993

Los Alamos APT Team

Outline

- **LE and HE linac design principles**
- **Accelerating structure physics**
- **Beam simulations**
- **Error studies**
- **Funnel design**

Low Energy Linac Design (< 20 MeV) Emphasizes Preservation of Beam Quality (Emittance)

- ECR ion source for high DC current with good emittance
- Low injection energy (75 keV) for high injector reliability
- High-energy RFQs for bunching & initial acceleration stage
- High structure frequency (350 MHz) reduces charge/bunch and provides strong transverse focusing
- Ramped accelerating field in DTL provides strong longitudinal focusing
- Precise matching between structures reduces beam heating shocks

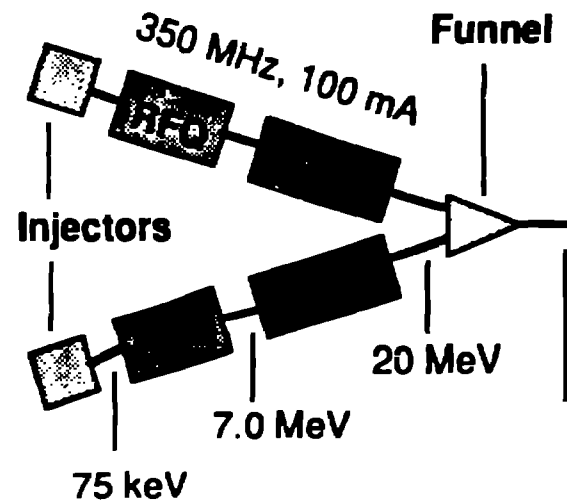

High Energy Linac Design (> 20 MeV) Balances Low Beam Loss With High RF Efficiency

- Very large ratio of accelerating structure aperture to rms beam size
- Strong transverse focusing (short accelerator tanks)
- No significant transitions in transverse or longitudinal acceptance
- Low accelerating gradient (1.0 MV/m)
- Doublet (FD) focusing minimizes beam transverse dimensions
- Bridge-coupled DTL is efficient structure for 20 - 100 MeV region
- 700 MHz frequency choice provides close to maximum RF efficiency

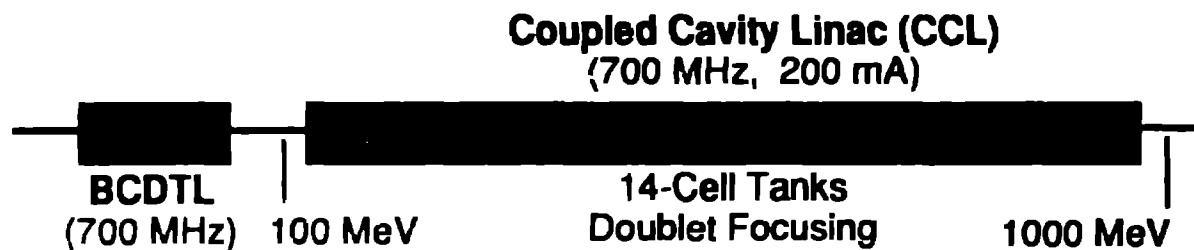

Ion Source Options

- **Electron Cyclotron Resonance (ECR) source**
 - **Most promising candidate**
 - **Proven, reliable cw operation**
 - **Excellent gas efficiency**
 - **Excellent power efficiency**
- **RF driven volume source with magnetic filter**
 - **Proven concept, scalable design**
 - **Requires high power and large gas flow**
- **Viable "standby" candidates**
 - **Filament-driven multicusp source**
 - **Single ring cusp field source**
 - **Duopigatron source**