

LA-UR-77-2452

CONF 77/11/29 JS

TITLE: DESIGN AND FABRICATION OF A RADIALLY-FED IMPLOSION HEATING COIL

MASTER

AUTHOR(S): L. D. Hansborough, J. M. Dickinson, J. G. Melton
W. C. Nunnally

SUBMITTED TO: The 7th Symposium on Engineering Problems of Fusion Research to be held in Knoxville, Tennessee, October 25 thru 28, 1977.

By acceptance of this article for publication, the publisher recognizes the Government's (license) rights in any copyright and the Government and its authorized representatives have unrestricted right to reproduce in whole or in part said article under any copyright secured by the publisher.

The Los Alamos Scientific Laboratory requests that the publisher identify this article as work performed under the auspices of the USERDA.



los alamos
scientific laboratory
of the University of California
LOS ALAMOS, NEW MEXICO 87544

An Affirmative Action/Equal Opportunity Employer

NOTICE
This report was prepared as an account of work sponsored by the United States Government. Neither the United States nor the United States Energy Research and Development Administration, nor any of their employees, nor any of their contractors, subcontractors, or their employees, make any warranty, express or implied, or assume any legal liability or responsibility for the accuracy, completeness, or usefulness of any information, apparatus, product, or process disclosed, or represents that its use would not infringe privately owned rights.

DESIGN AND FABRICATION OF A RADIALLY-FED IMPLOSION HEATING COIL

I. D. Hansborough, J. M. Dickinson, J. G. Melton, W. C. Nunnally

University of California
Los Alamos Scientific Laboratory
Los Alamos, New Mexico 87545

SUMMARY

A radially-fed implosion heating coil has been designed and fabricated at the Los Alamos Scientific Laboratory. The Marshall coil is a copper-plate-on-epoxy-substrate coil designed to utilize up to 200-kV to produce a 1-T magnetic field in a 20-cm bore with a risetime of no more than 250-ns. The design and fabrication process of this coil and the design of the high-voltage stand for the Marshall coil are discussed.

INTRODUCTION

The concept of a staged implosion or shock-heating followed by an adiabatic compression of a theta pinch plasma has been tested in the Staged Theta-Pinch Experiment (STP) which successfully used separate shock-heating and compression circuits. If one circuit is used, the shock-heating and compression fields must be supplied from one large high-voltage, low-inductance energy supply that has a high cost per joule. With separate circuits, the shock-heating field can be supplied from a high-voltage, low-inductance capacitor bank, which although having a high cost per joule, is relatively small. The slower rising compression field requires a large energy source, but the slower risetime allows it to be a relatively low-voltage and high-inductance having a lower cost per joule. Another benefit from staging is the fact that shock heating and compression fields can be programmed in such a manner that the plasma will have a relatively large plasma-to-wall radius (a/b) ratio which results in wall stabilization of the $l = 1$ instability.

To reduce the load inductance, it is necessary to use a fractional-turn coil. A full-turn, shock heating coil with a 20-cm bore requires 200-kV to 300-kV capacitors to achieve a 250-ns risetime with low-inductance source components. To reduce the required voltage, the STP experiment uses a simple half-turn coil. Because the implosion-circuit current and the compression-circuit current are passed through the same coil, the load inductance is much lower than the compression-circuit source inductance. This results in a poor energy transfer from the compression power supply and an undesirably short L/R compression-circuit current decay time. One method of resolving the conflicting coil inductance requirements is to use a low-inductance fractional-turn implosion coil compatible with a separate multiple-turn, compression coil. Dr. John Marshall conceived a coil to meet these requirements, and this unique coil is commonly known at LASL as the Marshall coil.^{1,2}

CONCEPT OF THE MARSHALL COIL

The Marshall coil geometry somewhat resembles a 10-T end-fed, ten conductor, 60-kV coil used for the CENTAUR experiment used at Culham Laboratory in the late 1960's,³ however, the Marshall coil uses many small conductors to allow an external magnetic field to penetrate through the coil. Although physically similar to past end-fed coils, the Marshall coil possesses many unique features.

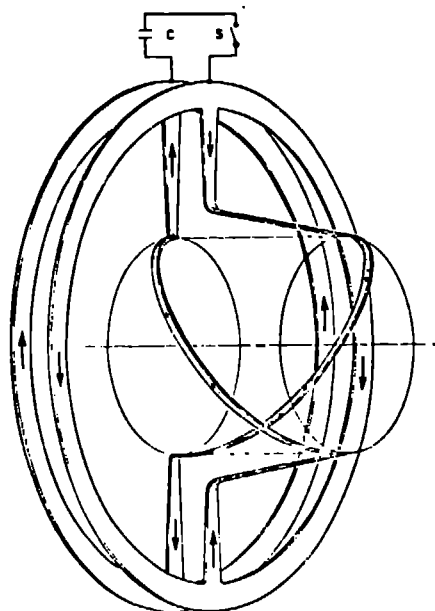

Fig. 1. Simple (two-conductor) Marshall coil showing current flow.

The geometry of the Marshall coil is simple, but difficult to describe. A simple half-turn, two-conductor Marshall coil is shown in Fig. 1. A capacitor (C) and a switch (S) are connected across the two circular conductor rings and the current path is completed through the Marshall coil. The current flows radially inward from the front ring, turns and flows axially to the front of the coils, reverses direction and makes a half-turn solenoidal path to the point where it flows radially outward to the rear ring. The current exits on the opposite side of the coil assembly from which it entered.

Figure 2 shows that the calculated inductance of the prototype Marshall coil by varying only one parameter at a time. Inductance is most strongly dependent on the bore diameter (D_i) and on the fractional number of turns (N), less sensitive to coil length (l), and it is rather insensitive to reasonable values of insulator thicknesses. Because the plasma diameter varies with time, the effect of the plasma on the coil inductance cannot be simply calculated; however, the presence of plasma with an $a/b = 0.8$ will drop the inductance by a factor of about 5.

In the bore, the conductors are made of many strips to force the current to make the required helical path and produce a uniform field. The conductors must be made of strips elsewhere in the coil to allow the field of the multi-turn compression coil to penetrate and couple. Coils will be mounted back-to-back as a module to reduce voltage-standoff problems

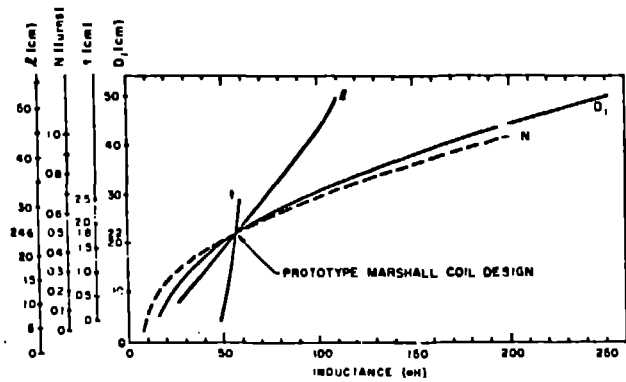

Fig. 2. Calculated Marshall coil inductance by variation of individual parameters.

between adjacent coils and to maximize the open space between radial feed plates; however, the windings of adjacent coils must be opposite hand to avoid producing a net radial field in the bore. A multi-turn coil would be wrapped around the cylindrical portion ("top hat") of the coil. Figure 3 illustrates the concept of a staged theta-pinch using Marshall coils. Note that the implosion power supplies are arranged radially around the discharge tube and drive the Marshall coils through a radial feed plate. The compression coil is isolated from the implosion field by magnetic material (iron). The implosion flux is insufficient to saturate the iron and couple to the compression circuitry, but the compression flux is sufficient to saturate the iron. When the iron saturates, the compression field penetrates between the Marshall coil conductors, and compresses the shock-heated plasma filling the bore. The width of the Marshall coil conductors and the gaps between adjacent conductors are equal (50% transparency) so that the implosion field returning through the iron and the Marshall coil brim

conductors will not be increased by more than a factor of two. As long as the conductor width is small compared with the substrate insulator thickness, the effect of the 50% transparency requirement does not appreciably increase the coil inductance over the solid conductor case.

The radial implosion-heating power-supply arrangement was selected to equalize and minimize the source inductance. It ensures an equally distributed and fast-rising implosion current in the Marshall coil while moving the capacitors and spark gaps away from the immediate vicinity of the plasma column. The radial arrangement also allows a significant amount of space for the implosion-heating system components.

FABRICATION OF THE PROTOTYPE MARSHALL COIL

It was decided in the fall of 1975 to design, fabricate, and test a prototype Marshall coil. Design of the prototype coil was completed in February 1976. It was fabricated at LASL and delivered for testing in April 1977. The prototype Marshall coil is illustrated in Fig. 4. Photographs of the coil during fabrication appear in Ref. 4. It has an outside diameter of 84-cm, a bore diameter of 22-cm, a length of 25-cm, and is designed for 200-kV. The coil contains 90 copper conductors (0.21-cm wide x 0.15-cm thick) that make a half-turn down the bore. The inductance of the prototype Marshall coil is calculated to be 56.7-nH. The epoxy substrate insulation thickness was selected to be 1.80-cm to duplicate the electrical characteristics expected from the ceramic coils necessary in a reactor environment. The implosion current is expected to rise in 250-ns and decay off with an L/R time of 70-ns. The peak implosion-heating current is approximately 400-kA and the peak voltage is about 140-kV. Because of the short duration and relatively low currents, the mechanical loads on the Marshall coil conductors are not large. The pressures were calculated to range from 4.21-psi in the brim area at the outside diameter of the brim to 61.8-psi at the bore diameter.

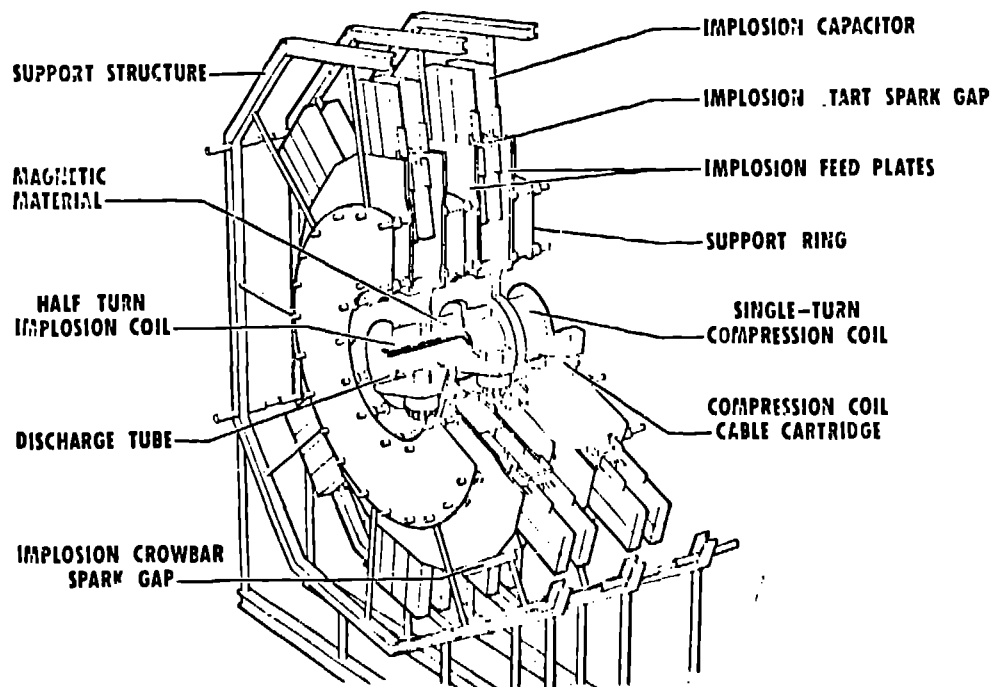

Fig. 3. Staged Theta Pinch modular assembly using Marshall implosion coils and a radial implosion power supply.

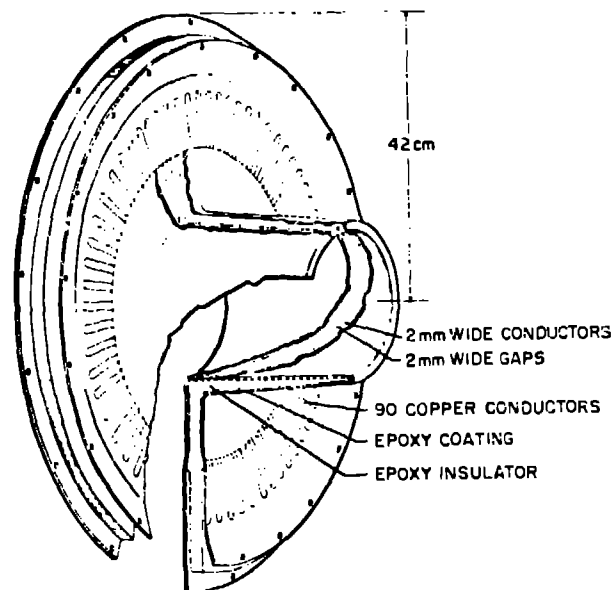

Fig. 4 Cutaway of the Prototype Marshall implosion coil.

The 1-T implosion field was calculated to produce 58.8-psi pressure on the inside of the bore. While the resulting stresses in the epoxy are low, the strength of the epoxy is also low (design tensile stress is a nominal 3000-psi). The strength of the "hat" may be easily strengthened by using some glass fibers in the external epoxy coating; however, adequate strength of the brim is a larger uncertainty.

Several fabrication methods for the prototype Marshall coil were considered. The fabrication method chosen was to directly plate the copper on an activated epoxy mandrel, machine conductor pattern, and then pot the coil in epoxy. This fabrication method was chosen because it required no large extension of existing technology, and details of this fabrication are described in Ref. 4.

Fabrication of the prototype Marshall coil took fourteen months and cost approximately \$60,000. Clearly, less time-consuming and expensive production methods must be found. The most likely method would be to do a hand layup of copper conductors on a die-cast epoxy substrate. This epoxy substrate would contain guides to allow accurate positioning of the copper conductors. If the requirement for tapered conductors can be relaxed, rectangular cross-section generator wire could be used. If this is not possible, many sheets of copper of the appropriate thickness could be cemented together, milled to the proper shape, and then separated. If one were willing to invest in a die, the conductors could also be stamped.

MARSHALL COIL TEST STAND

A stand shown on Fig. 5 has been fabricated to test the prototype Marshall coil. Because total system inductance is not of critical importance, a non-symmetric implosion-heating power supply may be used. Two multichannel coaxial spark gaps will fire two 0.2- μ F, 125-kV capacitors (one charged plus, the other charged minus) to allow testing of the Marshall coil to a maximum of 250-kV. Such an arrangement is possible because (1) the inductance of the current flow

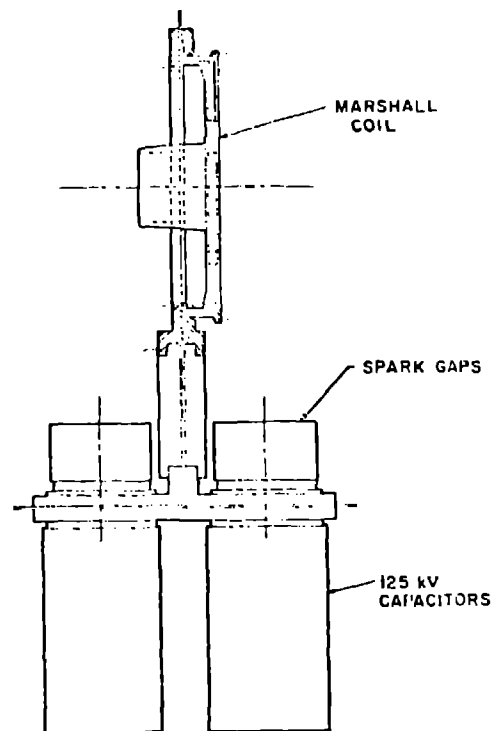

Fig. 5. Marshall coil test stand.

around the bore is about two-thirds of the inductance of the total system, and (2) the current path through the Marshall coil is always completely across the diameter of the coil. Therefore, the inductance of each conductor path is essentially equal. While utilizing existing high-voltage technology, the Marshall coil test stand suffers from the high inductance of two series spark gaps. For a radially-fed system shown in Fig. 3, it is estimated that the coil and feed plates will account for 89% of the circuit inductance with only 11% of the inductance in the capacitors and spark gaps. In contrast, the spark gaps and capacitors of the Marshall coil test stand account for 55% of the total system inductance; however, the test stand should be able to adequately test the prototype Marshall coil.

CONCLUSIONS

The use of a Marshall coil has several advantages for use with a theta-pinch plasma device. (1) it reduces the system cost by allowing the use of a relatively high-cost-per-joule, but small size implosion power supply, coupled with a relatively low-cost-per-joule compression power supply, (2) it reorients the implosion power supply to a series of planes orthogonal to the plasma axis, which gives more room for components, and (3) it allows tailoring the fractional turns and length of the coil to meet the implosion-field requirements. The disadvantage of the Marshall coil is that fabrication is difficult, and at present, expensive. Future engineering work on Marshall coil must concern itself with fabrication methods which allow high production rates and lowered costs.

REFERENCES

1. K. I. Thomassen (compiler), "Conceptual Design Study of a Scyllac Fusion Test Reactor," Los Alamos Scientific Laboratory Report LA-6924 (January 1976).
2. L. D. Hansborough, J. M. Dickinson, R. K. Linford, J. G. Melton, and W. C. Nunnally, "Engineering Aspects of the Marshall Implosion Coil," paper presented at the 1976 IEEE International Conference on Plasma Science, May 24-26, 1976, Austin, Texas.
3. K. Harries, F. G. Insinger, and T. E. James, "An Axially-Fed 100 kG Pulsed Field Coil, Report CIM-P 144, Culham Laboratory, Abingdon, Berkshire, United Kingdom, June 1967.
4. E. Eaton, A.G. Fox, and J. M. Dickinson, "Fabrication of an Epoxy-Insulated Marshall Coil," these proceedings.