

C.3

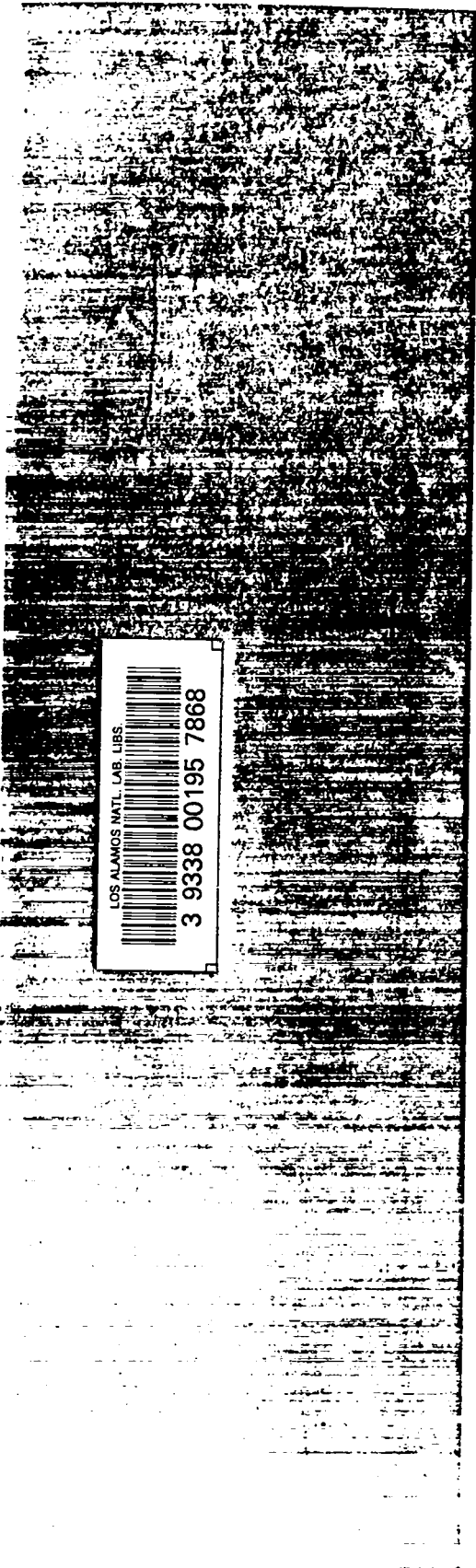

*The Potential of Die Casting for the  
Production of Near Net Shape Uranium Parts*

**REPRODUCTION  
COPY  
IS-4 REPORT SECTION**

**Los Alamos**  
NATIONAL LABORATORY

*Los Alamos National Laboratory is operated by the University of California  
for the United States Department of Energy under contract W-7405-ENG-36.*

*An Affirmative Action/Equal Opportunity Employer*

*This report was prepared as an account of work sponsored by an agency of the United States Government. Neither The Regents of the University of California, the United States Government nor any agency thereof, nor any of their employees, makes any warranty, express or implied, or assumes any legal liability or responsibility for the accuracy, completeness, or usefulness of any information, apparatus, product, or process disclosed, or represents that its use would not infringe privately owned rights. Reference herein to any specific commercial product, process, or service by trade name, trademark, manufacturer, or otherwise, does not necessarily constitute or imply its endorsement, recommendation, or favoring by The Regents of the University of California, the United States Government, or any agency thereof. The views and opinions of authors expressed herein do not necessarily state or reflect those of The Regents of the University of California, the United States Government, or any agency thereof.*

*The Potential of Die Casting for the  
Production of Near Net Shape Uranium Parts*

*Erica Robertson\**

*\*United States Air Force Academy  
Materials Division, Department of Engineering Mechanics  
HQ USAFA/DFEM, Fairchild Hall,  
Colorado Springs, CO 80840.*



LOS ALAMOS NATIONAL LABORATORY



3 9338 00195 7868

THE POTENTIAL OF DIE CASTING  
FOR THE PRODUCTION OF NEAR NET SHAPE URANIUM PARTS

by

Erica Robertson

ABSTRACT

This report was written to provide a detailed summary of a literature survey on the near net shape die casting process. Die casting is one of the near net shape casting technologies which could potentially satisfy the requirements of the LANL program titled Near Net Shape Casting of Uranium for Reduced Environmental, Safety and Health Impact. In this report, the die casting process is reviewed and an assessment of the ability to achieve the near net shape and waste minimization goals of the LANL program is made. It is concluded that while it has been demonstrated that uranium can be die cast into near net shapes, the die casting process is very complex and potentially costly from a design and capital equipment perspective. Also, it is questionable whether there would be a significant waste minimization generated by die casting when compared to that of other near net shape casting processes.

---

I. INTRODUCTION

The purpose of this report is to describe the die casting process and to determine the viability of using this technique to achieve near net shape uranium and uranium castings to minimize hazardous waste generation. A general description of the die casting process is given followed by a discussion of both the hot and cold chamber die casting machines, the advantages and disadvantages associated with die casting, and a summary of research findings concerning die casting experiments on such reactive metals as uranium and plutonium. The report is concluded with a section on the potential use of die casting as a technique by which near net shape uranium and uranium alloy castings could be made with concomitant hazardous waste generation reductions.

## II. PROCESS DESCRIPTION

Die casting is a casting technique in which a source of hydraulic energy is used to impart high velocity to molten metal to provide rapid filling of a metal die (mold). The die absorbs the stresses of injection, dissipates the heat contained in the metal, and facilitates the removal of the shaped part in preparation for the next cycle. The hydraulic energy is provided by a system that permits control of actuator position, velocity, and acceleration to optimize flow and force functions on the metal as it fills the cavity and solidifies.

## III. TWO VARIATIONS OF THE DIE CASTING PROCESS

### A. Hot Chamber Process

A diagram of a hot chamber die casting machine is shown in Fig. 1.<sup>1</sup> In the hot chamber process, the hydraulic actuator is in intimate contact with the molten metal. This minimizes exposure of the molten alloy to turbulence, oxidizing air, and heat loss during the transfer of the hydraulic energy.

### B. Cold Chamber Process

A diagram of a cold chamber die casting machine is shown in Fig. 2.<sup>1</sup> The primary difference between this machine and the hot chamber machine is that there is a molten metal reservoir which is separated from the actuator for most of the process cycle. Because of this arrangement, independent metering of the metal and immediate injection into the die is required. This setup exposes the hydraulic actuator to the molten metal for only a few seconds.

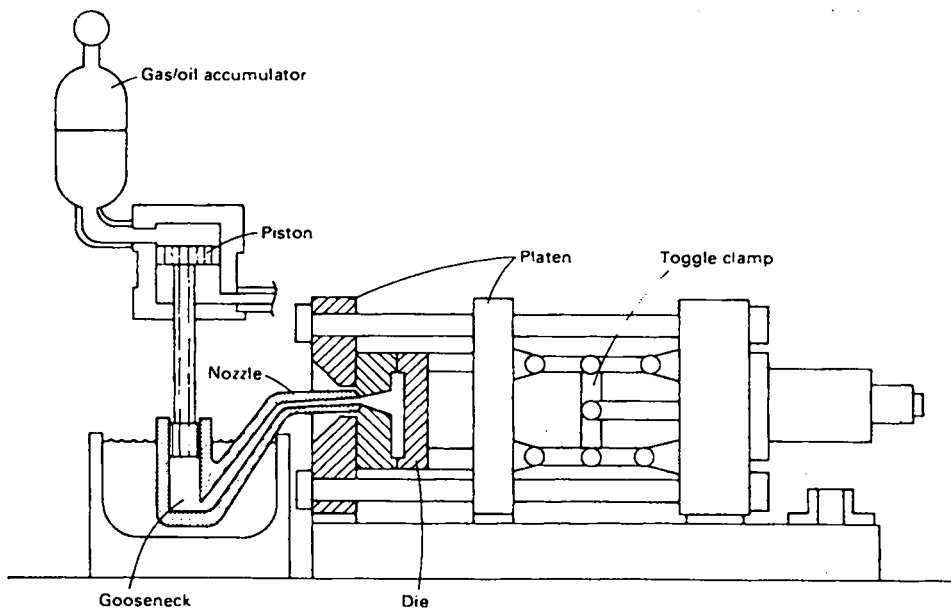

**Fig. 1** Schematic showing the principal components of a hot chamber die casting machine (ref. 1).

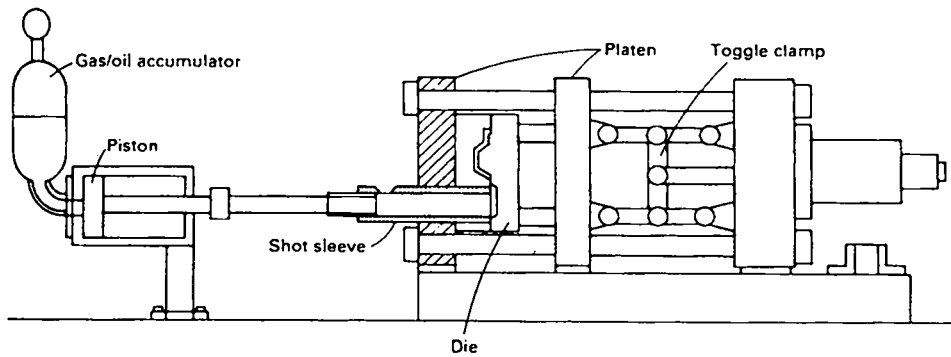

**Fig. 2** Schematic showing the principal components of a cold chamber die casting machine (ref. 1).

#### IV. ADVANTAGES

The primary advantage of die casting is the high speed nature of the process which allows the production of thin-wall complex shapes at economically high rates (approximately 100 parts per hour per cavity). A subsequent benefit related to the speed involved in die casting is that fine grained structures are achieved in the castings due to the rapid cooling the parts experience.

One other advantage associated with die casting is the degree of automation which can be incorporated into the process. Automation<sup>2-4</sup> has been incorporated into the following die casting operations: metal metering into the shot sleeve (cold chamber machines) or from the gooseneck molten metal reservoir (hot chamber machines), die and shot sleeve lubrication, casting removal. By using electronic controllers and monitors, important control variables such as die temperature, injection speed, locking force, hydraulic fluid temperature and the condition of the injection system may be monitored to warn of potential casting problems if they go outside of preset ranges.

#### V. DISADVANTAGES

The design of a die casting die is not simple. One problem that must be considered is how molten metal is fed to the die. This is often difficult because traditional feeding of solidification shrinkage is almost impossible. The design of the gating system is often complex as well. To design the gating system, the following factors need to be considered: part shape, internal quality, surface quality, mechanical properties, die temperature, die erosion, die material, die venting, metal temperature, metal fluidity, metal heat content and metal microstructure. This often results in trial and error adjustments to the gating system based on die casting experience. Hence, die design costs are often very expensive. However, there has been

some recent work in India on the development of a computer program with which to design die casting dies such that zinc die castings could be produced at low cost with zero defects.<sup>5</sup>

Another factor contributing to the overall expense of the die casting process is the cost of replacement dies. The thermal effects of molten metal flow affect die life and casting surface quality.<sup>6</sup> If not properly controlled, premature die failure from thermal fatigue can result, necessitating die replacement. In efforts aimed at increasing the useful lifetime of die both to reduce the cost per casting and to increase productivity, researchers at the NASA Lewis Research Center applied sputtered coatings of Pt, W, Si<sub>3</sub>N<sub>4</sub>, Mo or a Ag/Cu alloy to H13 steel used to fabricate dies for aluminum die castings.<sup>7</sup> It was concluded from this research that 1  $\mu$ m thick ion beam sputter deposited coatings of W and Pt were capable of reducing thermal fatigue in a simulation of aluminum die casting with H13 steel.

Although a die casting may be a near net shape product, when it is removed from the die casting machine it has flash, gates and overflows attached to it which must be removed by machining. Depending on the amount of machining required, this is another area which could contribute significant costs to the final product. However, there has been some progress in the automation of the deburring of die castings. One technique employs a wet vibratory plant to remove the small burrs which previously were removed by hand with files or scrapers.<sup>8</sup> This technique uses a container filled with die castings, abrasive chips (synthetic corundum), water soluble compounds which chemically attack the die casting surface (to influence color and shine) and water which is then subjected to a spiral vibratory pattern. By combining vibratory deburring with transport devices, automated supplies of compounds and a drying device, an automated, economical system for deburring and finishing die castings could be installed into production lines. This technique is most suitable for small die castings, a



large number of which could be placed together in a vibratory container. To automate deburring operations for larger die castings, the potential for robotic deburring exists. This potential was explored by the Bendix Corporation<sup>9</sup> on parts of hand size or larger. The conclusions presented in this work indicate that there is a potential to make robotic deburring viable if certain capabilities and limitations of robots are considered.

## VI. DIE CASTING EXPERIMENTS WITH PLUTONIUM AND URANIUM

### A. Plutonium

Die casting has been used successfully in the production of plutonium castings at the Lawrence Livermore Laboratory.<sup>10</sup> Die casting was shown to be an improvement over conventional pour-cast techniques in that the plutonium could be solidified more rapidly. This rapid solidification produced a finer cast structure. Another benefit was that because of the speed of the process, the plutonium had little time to react with its surroundings.

More details as to the design of low-pressure die casting equipment, thermal control, casting control, and molten metal filtration are provided in another report from researchers at Lawrence Livermore Laboratory.<sup>11</sup> Some of the conclusions presented were that 1) a thermal gradient was necessary in the mold wall to cast a sound part free of voids and 2) to eliminate the formation of oxide inclusions originating in the dross that forms on the surface of the melt, a piece of 40 mesh tantalum screen worked well as a filtration device.

In a report by J. E. Selle,<sup>12</sup> heat transfer and fluid flow calculations were solved to examine the feasibility of using different die coatings in conjunction with the plutonium die casting process. The purpose of applying coatings to the dies was to try to control the thermal gradients developed during the

casting process to ensure the production of a sound casting. The calculations considered such factors as the effect of surface roughness on fluid flow, conductance as a function of coating porosity, and solidification and remelting of microspheres of metal (defects observed in castings that appear to be related to cold shuts but have the appearance of splattered metal). Some conclusions from this report are summarized here:

1. The surface roughness of the coatings can cause a loss of 17% in incoming metal velocity through a 1/8 inch gate. This is not considered excessive.
2. "An insulating coating allows use of cooler dies, producing a subsequent refinement in grain size."
3. "Low density coatings provide better insulating capabilities than high-density coatings. With a porosity of 50%, the thermal conductivity of a porous coating is reduced to about 1/80th of that for 100% dense material."
4. CaO, Er<sub>2</sub>O<sub>3</sub>, and ZrO<sub>2</sub> have similar insulating capabilities.
5. Thick coatings provide better insulation than thin coatings.
6. "The time to solidify microspheres increases with radius. Formation of smaller microspheres can be prevented by increasing the die temperature or reducing metal turbulence. The time required to solidify microspheres can be increased about 20 times by using an insulating coating."

#### B. Uranium

In 1987, it was successfully demonstrated by S. L. Couling et al.<sup>13</sup> at Battelle that a uranium-3/4 wt% titanium alloy could be die cast with measured slug melting into penetrator castings for use in

the ammunition of the Air Force's GAU-8/A gun on the A-10 aircraft. A 600-ton Lester HHP-3X-S die casting machine was modified so that uranium could be cast. A schematic of the DU die-casting equipment is shown in Fig. 3.<sup>13</sup>

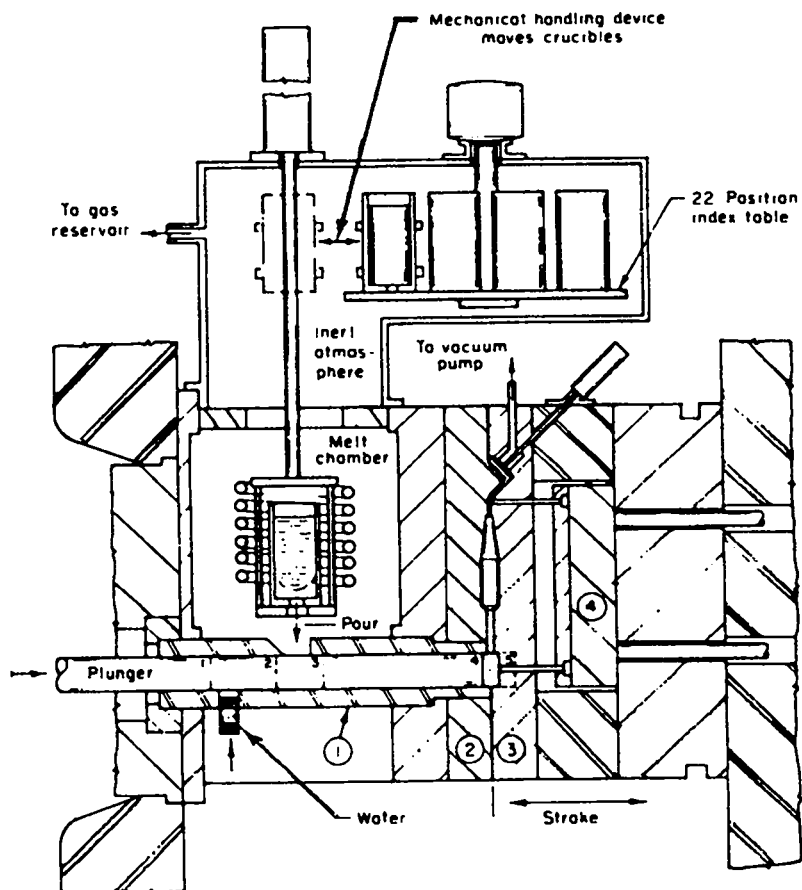

Fig. 3: Schematic of depleted uranium die casting equipment (ref. 13).

A 22 position index table enclosed in an inert atmosphere held 22 graphite crucibles containing billets of the uranium alloy. A crucible was then lowered via an elevator into the induction coil. The induction coil and crucible were arranged such that the molten metal (1300°C) was poured directly into the shot sleeve (preheated to 600°C, fabricated from TZM molybdenum or the tungsten alloy Anviloy 1150). An operator then pushed a button to activate the

plunger (made from Anviloy 1150 but protected from contact with molten uranium by a graphite wafer) which forced the molten metal into the die (preheated to 500°C, made from TZM molybdenum). After a dwell time of 4 seconds, the dies were parted and the operator extracted the casting with tongs and quenched the casting into an oil bath. The empty crucible was then raised and replaced with a full one and the process repeated.

This experiment was considered successful even though there were some porosity problems in the nose sections of the castings. By changing the size of the ingate and the speed of the piston, the amount of porosity was decreased from 1.3-2.2 percent down to less than 0.4%. However, no DU penetrators were produced by this method because of the cost associated with reprocessing the DU scrap back into billet form.

#### VII. AN ASSESSMENT OF THE POTENTIAL FOR USING DIE CASTING TO PRODUCE NEAR NET SHAPES WITH MINIMUM WASTE GENERATION

While it has been demonstrated that uranium or uranium alloys can in fact be successfully die cast into near net shapes, there are some economic factors that need to be seriously considered: the cost of capital equipment, the cost and time involved in achieving the desired die design, the costs of dies and replacement dies, and the amount of waste generated during the process and whether or not the scrap material may be cost-effectively recycled. Die castings, in general, require more machining operations to remove excess scrap material than castings produced by other techniques such as investment casting. There is often excess material, flash, protruding from the parting line in addition to the often complex arrangement of ingates and sprues. The complete removal of all extraneous material and any subsequent surface finishing operations may significantly increase the cost of the final product. However, if these machining wastes could be recycled, perhaps the economy of the process would improve. Before

a uranium die casting technique, such as described in the previous section, could be selected as a reasonable means of achieving near net shapes and waste minimization, a cost-benefit analysis should be performed and compared to similar analyses of other near net shape fabrication methods to determine which process is capable of achieving a program's goals within reasonable costs.

#### VIII. ACKNOWLEDGEMENTS

The author acknowledges the Air Force Office of Scientific Research for the position of Military Research Associate in the MST-6 Group at Los Alamos National Laboratory.

#### IX. REFERENCES

1. *Metals Handbook*, 9th ed., Volume 15, (ASM International, Metals Park, OH, 1988), pp. 286-287.
2. S. E. Booth, "British Non-Ferrous Guide to Better Aluminum Diecasting," BNF Metals Technology Centre, Wantage, England, Report No: PB83-203760, (1973).
3. T. B. Hill, "Magnesium Diecasting: Process Variables and Fault Correction," BNF Metals Technology Centre, Wantage, England, Report No: PB83-206334, (1982).
4. G. O. Cowie, "Capabilities and Product Characterization of Die Casting Process," in *Proceedings of Near Net Shape Manufacturing for the Automotive Industry*, ASM International Meeting 8-10 October 1990, Cobo Hall, Detroit, MI.
5. "Computer Aids for the Die Caster," Indian Lead Zinc Information Centre, New Delhi, PB81-145179, (1980).
6. "Seminar on Diecasting Die Design - A Scientific Approach," Diecasting Society of India, New Delhi, 1981.
7. M. J. Mirtich, C. Y. Nieh, and J. F. Wallace, "Sputtered Protective Coatings for Die Casting Dies," NASA Technical Memorandum 81735, (April 1981).
8. H. M. Loeschbart, "Deburring Die-Castings by Wet Vibratory Plant," Translation from *Geisserei*, 58 (1), 6-9, (14 Jan. 1971).
9. L. K. Gillespie, "Robotic Deburring Part I: Preliminary

Observations," The Bendix Corporation, BDX-613-3060, Topical Report, (April 1984).

10. R. L. Rose and B. A. Kuhn, "Die Casting Plutonium," Lawrence Livermore Laboratory Report: UCRL-52259, (April 14, 1977).

11. T. L. Rising, "Design Goals of the Plutonium Die Casting Process," *Transactions SDCE 12th International Die Casting Congress and Exposition*, Minneapolis Convention Center, Oct. 31 - Nov. 3, 1983, Paper No: G-T83-064.

12. J. E. Selle, "A Summary of Special Coatings Projects Conducted in Support of the Die-Casting Program," Rockwell International Report: RFP-4162, (September 12, 1988).

13. S. L. Couling, J. D. Myers, and F. C. Bennett, "A Die Casting Process for Producing Depleted Uranium Parts," *Transactions SDCE 14th Die Casting Congress and Exposition*, May 11-14, 1987, Toronto, Ontario, Canada, Paper No: G-T87-039.

This report has been reproduced directly from the best available copy.

It is available to DOE and DOE contractors from the Office of Scientific and Technical Information,  
P.O. Box 62,  
Oak Ridge, TN 37831.  
Prices are available from  
(615) 576-8401.

It is available to the public from the National Technical Information Service,  
U.S. Department of Commerce,  
5285 Port Royal Rd.,  
Springfield, VA 22161.

LOS ALAMOS NAT'L LAB.  
IS-4 REPORT SECTION  
RECEIVED

'93 SEP 2 AM 10 16

**Los Alamos**  
NATIONAL LABORATORY

Los Alamos, New Mexico 87545