

LA-3654

C. 33

CIC-14 REPORT COLLECTION
REPRODUCTION
COPY

LOS ALAMOS SCIENTIFIC LABORATORY
of the
University of California
LOS ALAMOS • NEW MEXICO

Detection of Plutonium Penetrations
Through Containers at High Temperature

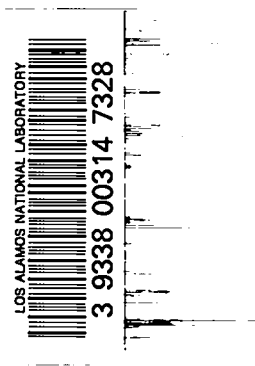

UNITED STATES
ATOMIC ENERGY COMMISSION
CONTRACT W-7405-ENG. 36

LEGAL NOTICE

This report was prepared as an account of Government sponsored work. Neither the United States, nor the Commission, nor any person acting on behalf of the Commission:

A. Makes any warranty or representation, expressed or implied, with respect to the accuracy, completeness, or usefulness of the information contained in this report, or that the use of any information, apparatus, method, or process disclosed in this report may not infringe privately owned rights; or

B. Assumes any liabilities with respect to the use of, or for damages resulting from the use of any information, apparatus, method, or process disclosed in this report.

As used in the above, "person acting on behalf of the Commission" includes any employee or contractor of the Commission, or employee of such contractor, to the extent that such employee or contractor of the Commission, or employee of such contractor prepares, disseminates, or provides access to, any information pursuant to his employment or contract with the Commission, or his employment with such contractor.

This report expresses the opinions of the author or authors and does not necessarily reflect the opinions or views of the Los Alamos Scientific Laboratory.

Printed in the United States of America. Available from
Clearinghouse for Federal Scientific and Technical Information
National Bureau of Standards, U. S. Department of Commerce
Springfield, Virginia 22151

Price: Printed Copy \$3.00; Microfiche \$0.65

LA-3654
UC-80, REACTOR
TECHNOLOGY
TID-4500

LOS ALAMOS SCIENTIFIC LABORATORY
of the
University of California
LOS ALAMOS • NEW MEXICO

Report written: December 1966

Report distributed: March 23, 1967

Detection of Plutonium Penetrations
Through Containers at High Temperature

by

Dale M. Holm and Bill M. Moore



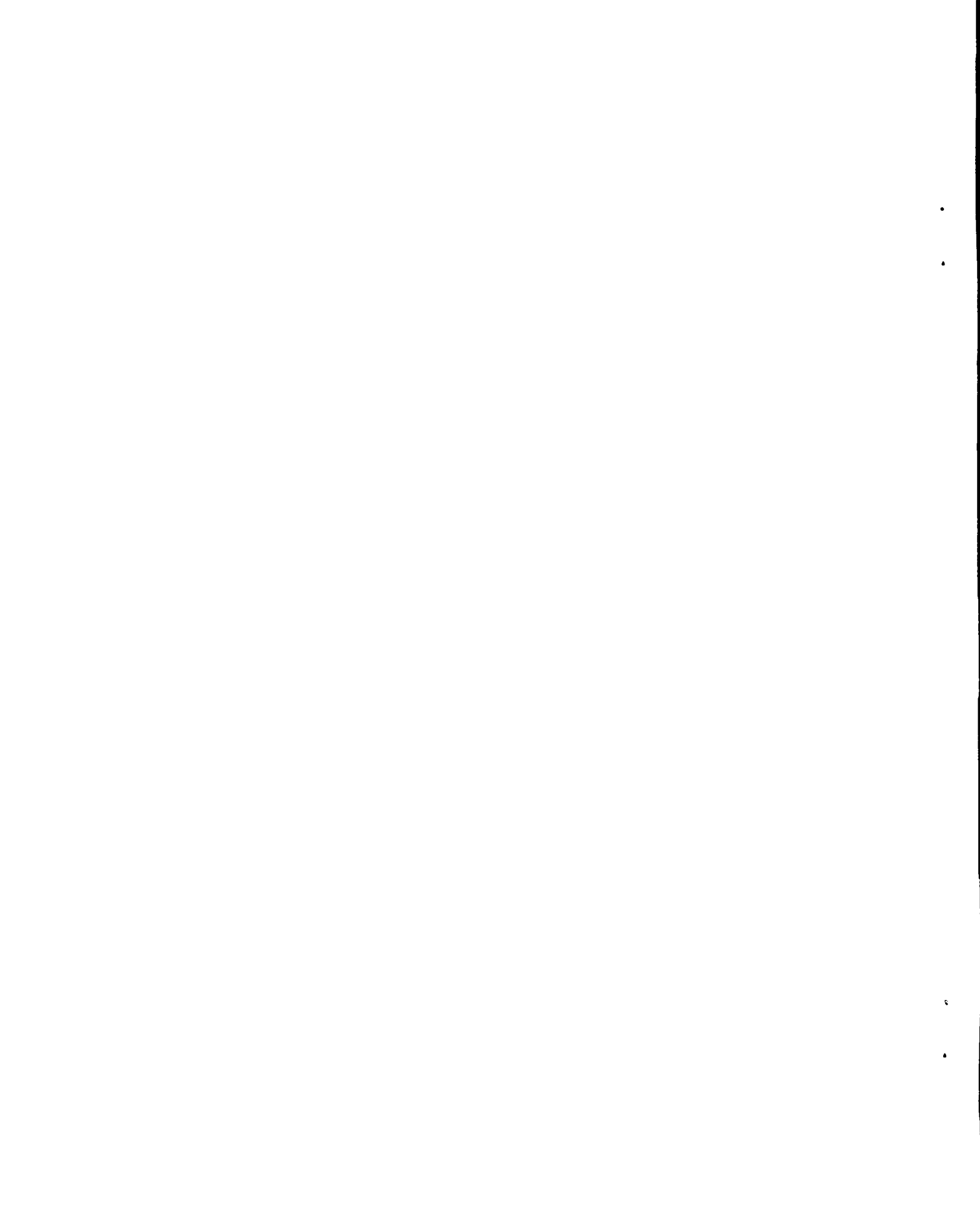

ABSTRACT

A detection system has been built for monitoring plutonium penetration through tantalum capsules by counting alpha particles with silicon surface barrier detectors. Small amounts of plutonium (0.1 μg) can be detected on the surface of the test capsule while it is at 1160°C in a high vacuum. The detectors are kept cool by placing them in water-cooled head assemblies and shielding them from thermal radiation by six thin nickel foils. Alpha particles from plutonium lose about 1.5 MeV of their energy in traversing the foils. A total running time of 18,548 h was logged on two systems, during which 116 capsules were tested. No operator was required in attendance because the experiment was automatically shut down when the leak reached a predetermined value.

•

•

•

•

INTRODUCTION

The Los Alamos Molten Plutonium Reactor Experiment (LAMPRE)⁽¹⁾ demonstrated the feasibility of using a liquid plutonium alloy as a reactor fuel. In conjunction with this reactor experiment, a materials testing program was carried out to find an optimum container. Fuel elements were tested in sodium loops at temperatures of 500-750°C. After 500, 750, and 1000 h, the fuel elements were withdrawn from the sodium, frozen, and examined for plutonium leakage. This method of testing was time consuming, made it difficult to determine the time of failure, and introduced additional stresses on the capsule by the expansion of the plutonium alloy on freezing. To improve the testing method, an apparatus operating at higher temperatures, with a high vacuum in place of sodium, was designed.^(2,3) The elevated temperatures accelerated the rate of corrosion, failure of the capsule could easily be detected by monitoring the capsule for alpha activity, and the tests could be run without freezing the fuel.

The tantalum capsule was monitored for alpha activity by two water-cooled detector head assemblies located at the top and bottom of the quartz-walled apparatus (Fig. 1), outside the heated zone. Each assembly included three silicon surface barrier semiconductors with their associated radiation shields, which were thin nickel sheets to prevent excessive heating of the detectors by thermal radiation from the capsule and the furnace walls. Although the solid angle subtended by the six detectors was small, the high specific alpha activity from the plutonium was sufficient to allow the detection of 0.1 µg of plutonium on the surface of the test capsule.

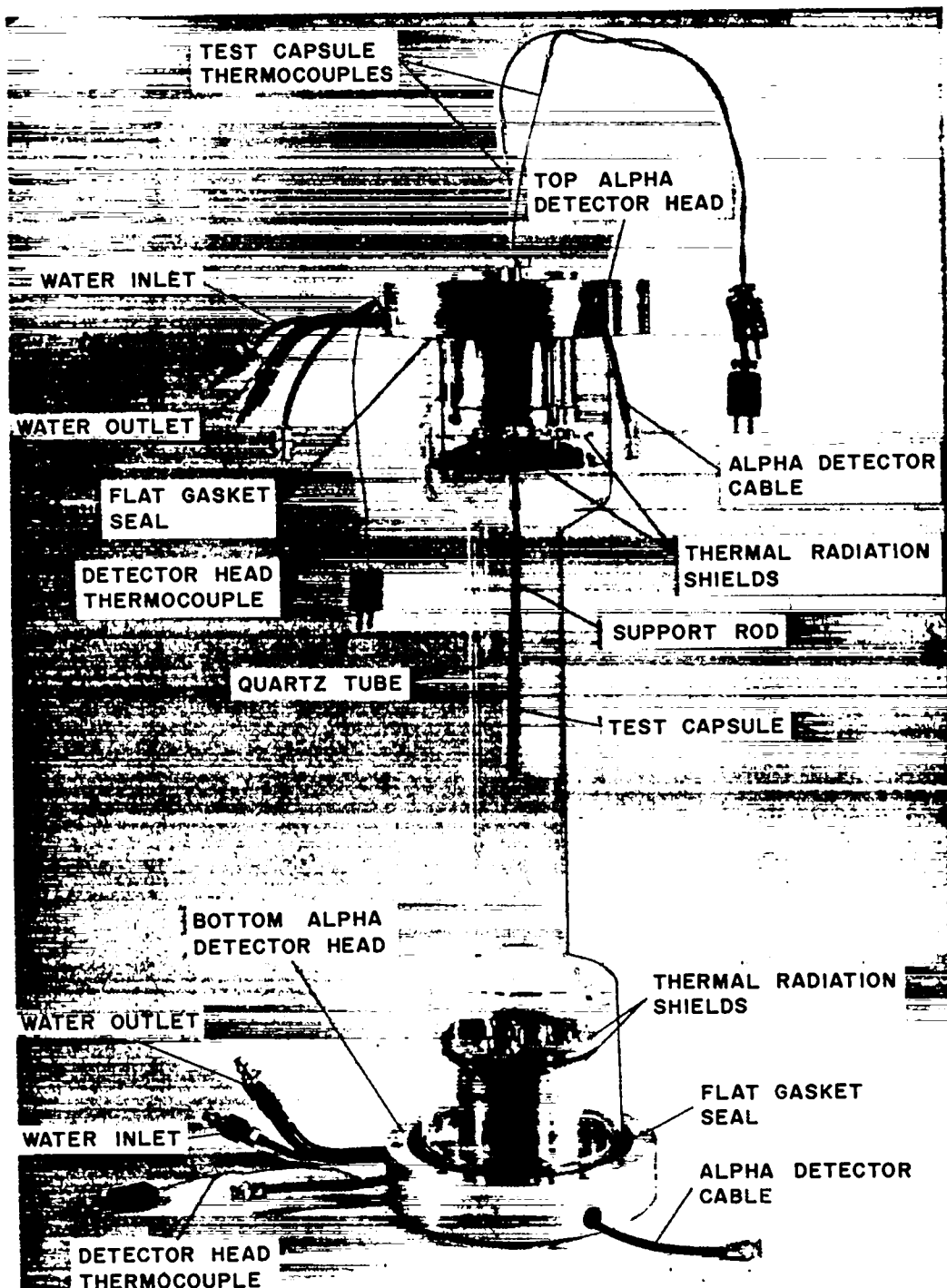

Fig. 1. Accelerated corrosion testing apparatus.

DETECTOR SYSTEM

The detector system for the accelerated corrosion testing apparatus had to operate in a high vacuum (10^{-7} torr), near portions of the apparatus which were at temperatures up to 1160°C . In addition, the system had to be reliable for unattended operation in runs of several hundred hours, with a system time response of less than five minutes from the inception of the leak to shutdown of the apparatus.

The detector system used for this application is shown in Figs. 1 and 2. The top and bottom detector head assemblies each house three ORTEC model SBG J 300-60 3-cm^2 silicon surface barrier detectors. The lower head assembly was held in the center of the quartz tube with three spokes. The space between the spokes provided the path for the vacuum pumping, while the water pipes and the cables for the detectors were fed through the spokes. Access to the cables and detector feedthrough was obtained by an O-ring-sealed cap. Since heating had to be uniform along the length of the capsule, the quartz tube had to be long and thin. However, so that the detectors might subtend the largest possible solid angle and thus have the highest possible sensitivity, the tube was enlarged at each end of the heated portion.

Since the detectors had to be operated below 65°C , the detector head was cooled with water at 6°C . The water passages were made by machining grooves into separate pieces of aluminum which were then bonded together with Shell Epon Adhesive No. 934. The best results were obtained by machining (without lubricant) the mating surfaces just before bonding. Further protection of the detectors was necessary because of the large amount of heat radiating from the furnace and the capsule. This protection was furnished by six nickel foils interposed between the detector and the heat source. The two foils (each $50\ \mu\text{in.}$ thick) nearest the capsule were mounted on a thermally isolated sheet, and the other four (each $20\ \mu\text{in.}$ thick) were mounted inside the water-cooled assembly.

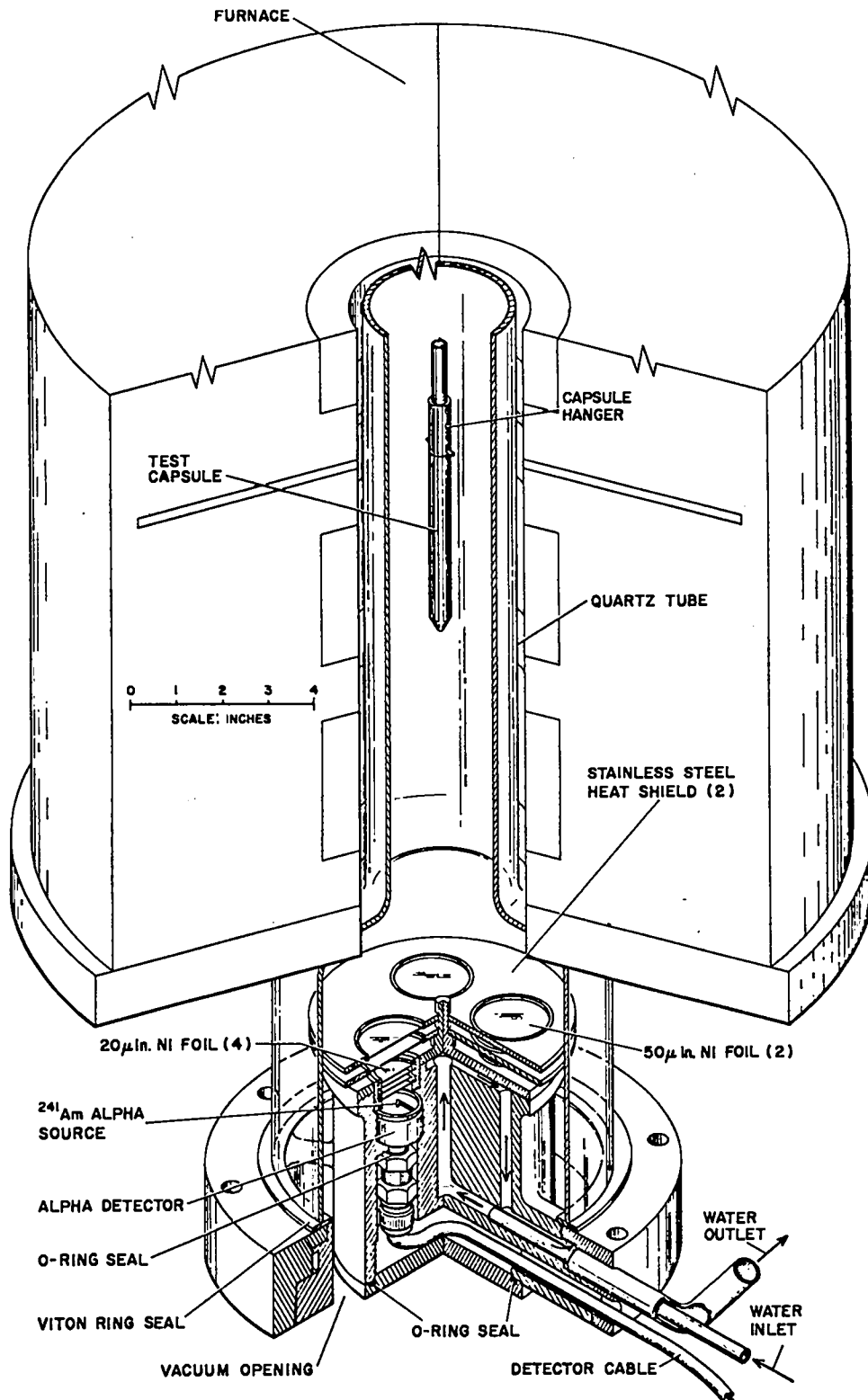

Fig. 2. Detail of lower detector head.

Since many of the experiments lasted for hundreds of hours, it was necessary to monitor each detector with a calibration source to make certain that the detector was functioning properly. Therefore, a 5.48-MeV ^{241}Am alpha source was placed near each detector. The background counting rate of about 2 counts/sec from each of these sources did not seriously interfere with the plutonium signal, because the 5.15-MeV alphas from the plutonium lost about 1.5 MeV in penetrating the nickel foils. This energy separation, coupled with good energy resolution and small straggling in the thin ^{241}Am sources, made it easy to distinguish the plutonium signal from the calibration signal. The ^{241}Am sources were made by evaporating AmO_2 onto the ends of small wires.

It was found that the effective solid angle subtended by the detectors was only about 10% of that calculated from the geometrical configuration. This disparity was probably caused by the combination of capsule surface roughness and the oblique angle of viewing. The absolute sensitivity for detection was lowered, but the relative sensitivity did not change significantly with different capsules; therefore, no serious errors occurred in determining the time of penetration. Six detectors were used so that each point on the capsule was seen by at least two detectors, thus increasing the reliability of detection. Therefore, in principle, three of the detectors could have failed during an experiment without seriously jeopardizing the results.

ELECTRONICS

The electronic components were set up as shown in Fig. 3 for automatic and unattended operation. Each detector had its own preamplifier and short connecting cable, so that the input capacitance to the preamplifier could be maintained at the lowest value, and thus the highest signal-to-noise ratio could be attained. Although this arrangement decreased the pulse amplitudes, it made isolation of defective detectors easier during the course of the experiments. After the pulses from the six detectors were mixed in the circuit shown in Fig. 4, the combined

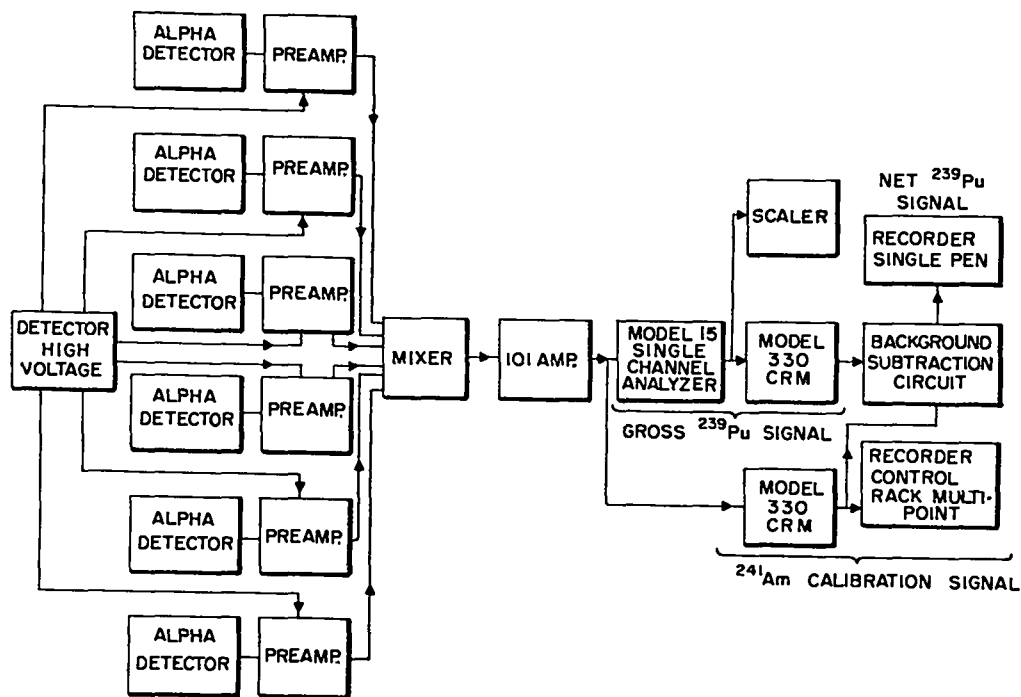

Fig. 3. Alpha detection system for the accelerated corrosion testing apparatus.

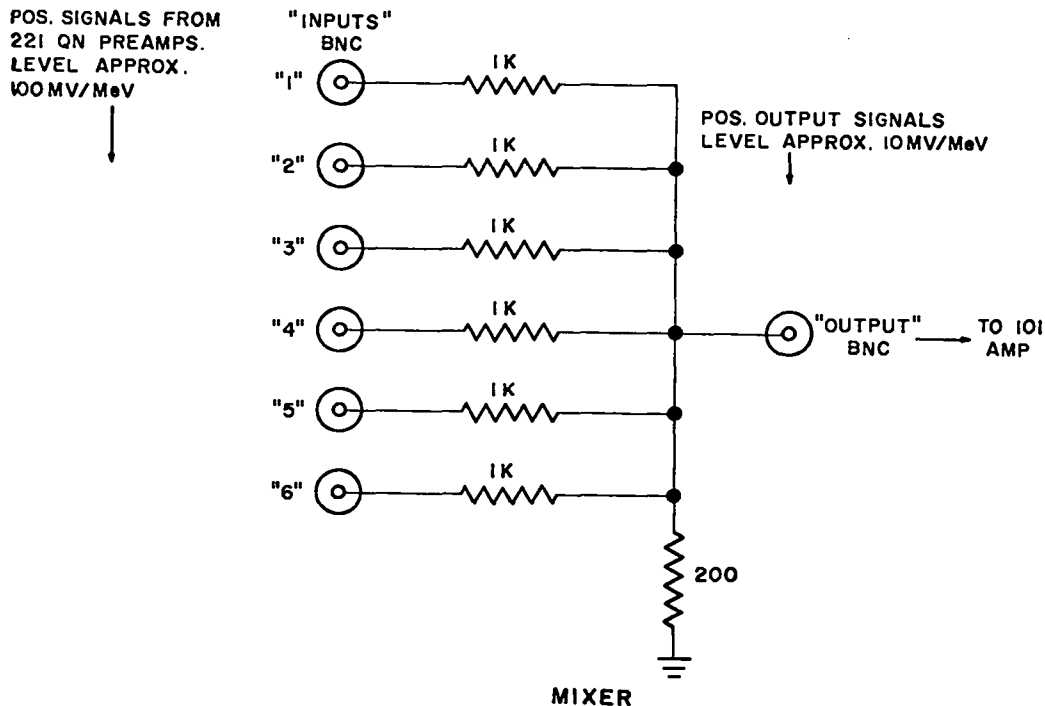

Fig. 4. Mixer circuit.

signals were amplified and sent to two subsystems where the plutonium and the ^{241}Am pulses were separated and individually monitored as dc voltages on recorders. A counting rate of 1.5 counts/sec from a plutonium leak activated the microswitch on the single-pen recorder and caused the automatic shutdown of the experiment.

The principal function of the ^{241}Am calibration signal was to show that the detection system was operating at all times during the experiment. As long as the signal on the multipoint recorder was within the proper limits, the operator could be assured that the calibration system was operating properly. Since a part of the plutonium detection system was not monitored (a single-channel analyzer, a count-rate meter, a subtraction circuit, and a single-pen recorder), there was a possibility that a leak would not be detected. Therefore, the calibration monitor discriminator on the count-rate meter was set to include all energies above 1.5 MeV, so that a leak of about 10 μg could be detected on the multipoint recorder monitoring the ^{241}Am signal. The sensitivity of this type of leak detection was low enough that the number of counts from a 1- μg leak would be small compared to the calibration signal, and no serious errors were introduced in the background subtraction. However, if a leak was not detected in the normal manner, it would be observed on the calibration signal after it had reached 10 μg . The count-rate meter had a 40-sec time constant, and 20 counts/sec gave full-scale deflection on the multipoint recorder.

Figure 5 shows the pulse height distribution from the amplifier at different times during a run. The plutonium signal was contained in the peak centered on channel 63, and the calibration signal was in channels 80-100. Thus, the single-channel analyzer, set to include channels 26-78, indicated the presence of a plutonium leak. Since the signal counts were very low, the count-rate meter was set for 5 counts/sec full scale with a 40-sec time constant, to smooth out the statistical fluctuations. From Fig. 5, it can be seen that a background counting rate of about 0.4

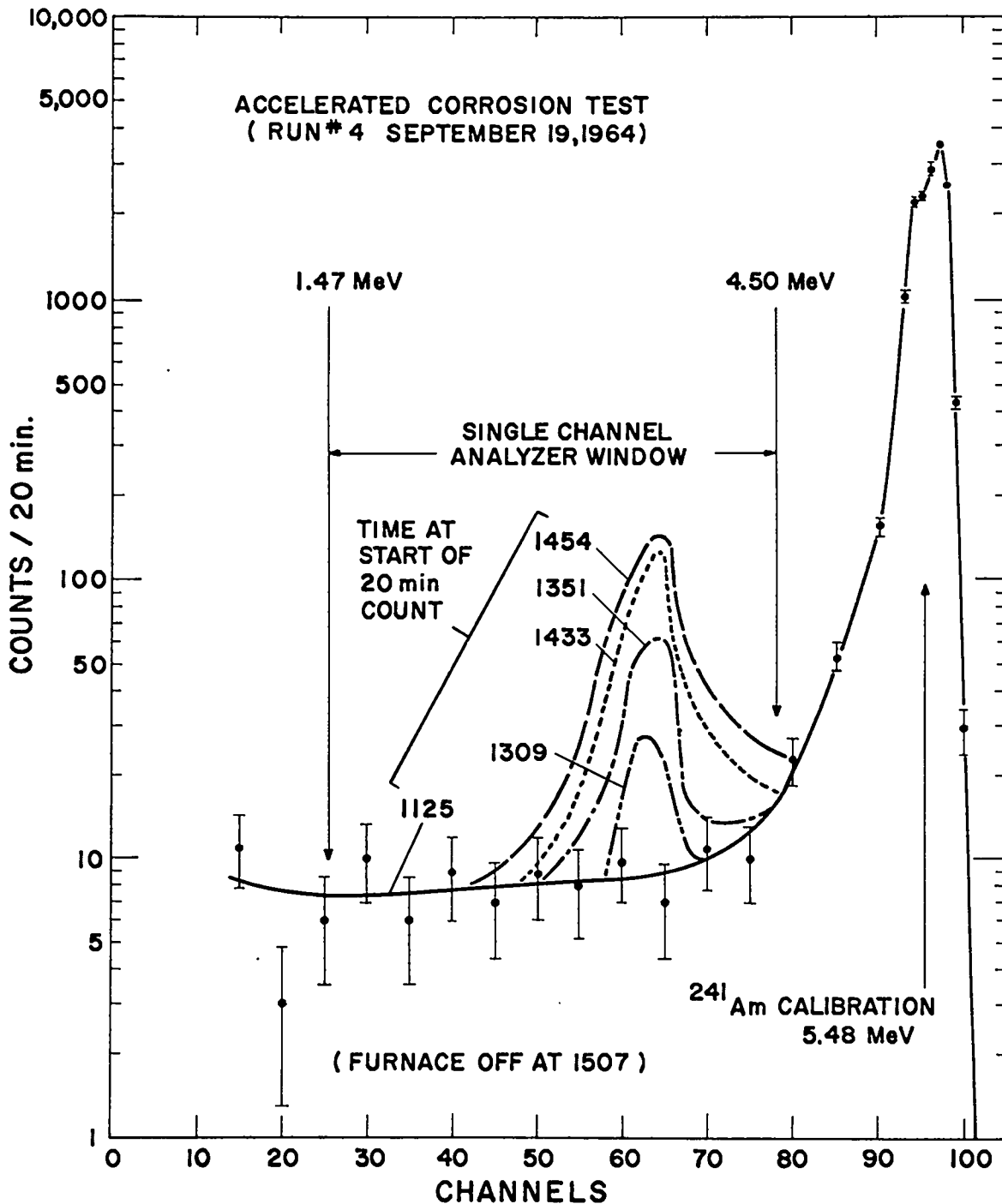

Fig. 5. Pulse height distribution from amplifier.

counts/sec was present, due to low-energy pulses from the calibration signal. This background made it difficult to determine the precise time at which a leak began, so it was suppressed by the background subtraction circuit.

The background subtraction circuit shown in Fig. 6 provided a dc voltage proportional to the amount of ^{241}Am background, thus lowering the baseline of the recorder off scale. The beginning of a leak would then be clearly evident on the strip chart. This device can be used to change the effective zero voltage of the recorder and magnify the positive deviation from the new baseline, so that changes can be seen more easily. If the baseline were always constant, a voltage divider on a battery could have been used to provide the required shift, but this arrangement would overcorrect if one or more detectors stopped counting. In this type of situation, the subtraction circuit compensates automatically.

The inputs to the subtraction circuit were from the plutonium detection system and the americium detection system (Fig. 3). The scale settings on the count-rate meters were adjusted so that the signals would be at suitable positions on their respective recorders. Thus, the input dc voltages were proportional to the counting rates of the two signals, but the proportionality factors differed because of the differences in scale settings. The fraction of the americium signal fed to the recorder was adjusted to balance out the background signal in the plutonium channel when no plutonium was present. The subtraction circuit permitted monitoring of either of the output signals separately or of the net output signal.

RESULTS

Experiments performed with the accelerated corrosion testing apparatus have been described in detail.⁽⁴⁾ The results pertinent to the detector system will be described here.

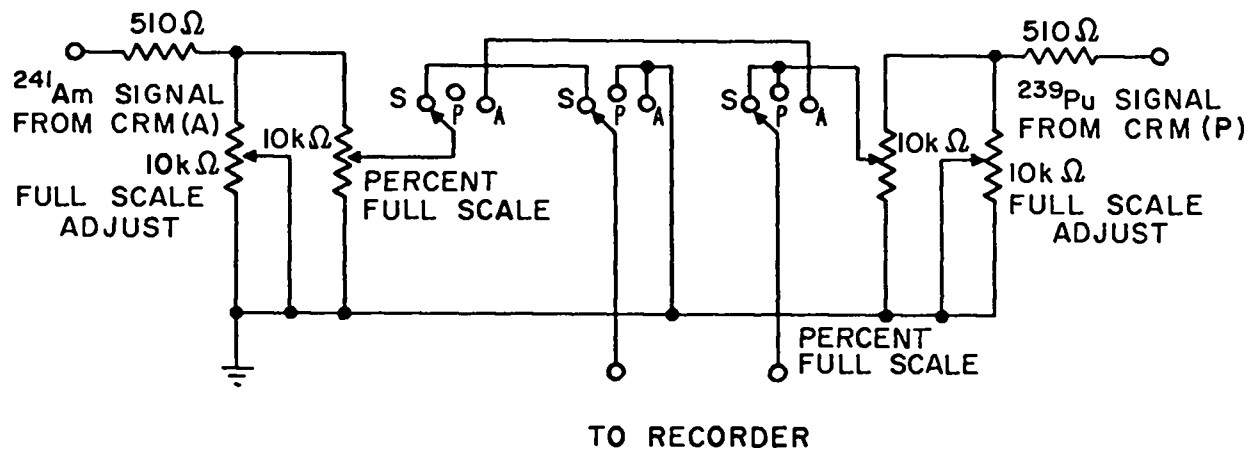

S = SUBTRACTION

Fig. 6. Background subtraction circuit.

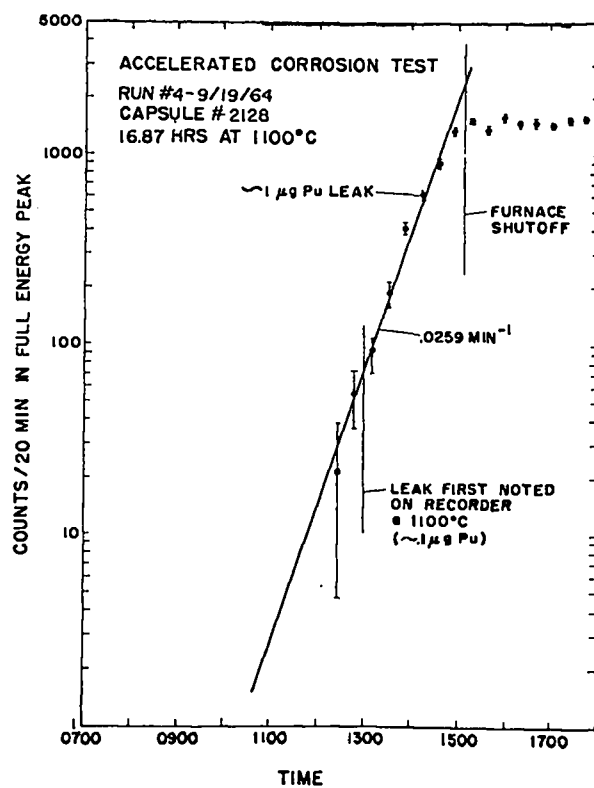

Fig. 7. Integral of counts from plutonium peak.

Two complete sets of apparatus were used during two years of testing, in which 116 capsules were tested, and a total running time of 18,548 h (773 days) was logged. The longest run without a leak was 1760 h at 1100°C. During the two years, the responses of 40 detectors deteriorated. This deterioration resulted from increased leakage current which, in turn, was caused by the loss of water molecules that maintain the potential differences on the surfaces of the detectors. The water was lost because of the vacuum environment in which the detectors were operated. The detectors could be rejuvenated by being left in the air for a few weeks.

Although it was originally feared that the apparatus would be badly contaminated by each capsule that leaked, the high sensitivity of the detector system made it possible to detect leaks that were confined to an adherent layer on the surfaces contacted. Since a small amount of contamination usually appeared on the innermost nickel foils, they were replaced after each run. A disposable quartz sleeve was placed inside the main furnace to collect the rest of the contamination when a leak occurred. In general, after a leak, no contamination could be detected by swipe tests of the surfaces exposed to the plutonium leak, although one massive failure occurred in which much loose contamination was found.

The integral of the counts representing the net leakage (channels 26-78 from Fig. 5) has been plotted in Fig. 7 along with data from other spectra not plotted in Fig. 5. The counts from the spectrum taken at 1125 (Fig. 5) were used as the background. Figure 7 illustrates the unambiguous detection of a leak with the aid of a pulse height analyzer counting for 20 minutes. In normal operation, the recorder monitored the leaks, and the analyzer was used to check the electronics periodically and to verify that a peak from ^{239}Pu appeared in the proper place in the pulse height distribution when a leak was indicated by the recorder.

CONCLUSIONS

Silicon surface barrier detectors, with appropriate shielding and cooling, can be operated within their temperature limitations at distances less than 4 in. from furnace walls at 1160°C. Small plutonium leaks (1 μg) could be detected routinely with automatic operation of the system. Higher sensitivity could have been obtained by using absorbers to degrade the energy of the calibration sources to about 2 MeV, and the background suppression would not have been necessary. However, the sensitivity was adequate for the particular application.

REFERENCES

1. "LAMPRE I Final Design Status Report," LA-2833 (January 1962).
2. R. L. Andelin, A. R. Hawkins, and N. G. Wilson, "A New Technique for Testing Molten Plutonium Container Materials at High Temperature," *Trans. Am. Nucl. Soc.* 8, 19 (1965).
3. B. M. Moore, D. M. Holm, H. M. Ruess, and R. L. Andelin, "Detection of Plutonium Penetration Through Containers at High Temperatures," *Trans. Am. Nucl. Soc.* 8, 174 (1965).
4. R. L. Andelin, L. D. Kirkbride, and R. H. Perkins, "High Temperature Environmental Testing of Liquid Plutonium Fuels," LA-3631 (in press).