

LA-8786

C.3

CIC-14 REPORT COLLECTION

REPRODUCTION
COPY

On Vacuum Ultraviolet Light Production
by Nuclear Irradiation
of Liquid and Gaseous Xenon

University of California



LOS ALAMOS SCIENTIFIC LABORATORY

Post Office Box 1663 Los Alamos, New Mexico 87545

Photocomposition by

Mary Louise Garcia

DISCLAIMER

This report was prepared as an account of work sponsored by an agency of the United States Government. Neither the United States Government nor any agency thereof, nor any of their employees, makes any warranty, express or implied, or assumes any legal liability or responsibility for the accuracy, completeness, or usefulness of any information, apparatus, product, or process disclosed, or represents that its use would not infringe privately owned rights. Reference herein to any specific commercial product, process, or service by trade name, trademark, manufacturer, or otherwise, does not necessarily constitute or imply its endorsement, recommendation, or favoring by the United States Government or any agency thereof. The views and opinions of authors expressed herein do not necessarily state or reflect those of the United States Government or any agency thereof.

LA-8786

UC-34

Issued: May 1981

**On Vacuum Ultraviolet Light Production
by Nuclear Irradiation
of Liquid and Gaseous Xenon**



G. C. Baldwin

LOS ALAMOS NATL. LAB. LIBS.
3 9338 00307 1981



ON VACUUM ULTRAVIOLET LIGHT PRODUCTION BY NUCLEAR IRRADIATION OF LIQUID AND GASEOUS XENON

by

G. C. Baldwin

ABSTRACT

Recent Los Alamos investigations suggest that a liquefied noble element may be the long-sought medium for a nuclear-excited laser or flashlamp. This report suggests research needed to confirm this finding and to provide a basis for design and application studies. Quantitative and qualitative information are needed on the nature and behavior of the excited species, the effects of impurities and additives in the liquid phase under nuclear excitation, and the existence and magnitudes of nonlinear effects. Questions that need to be addressed and the most appropriate types of facilities for this task are identified.

INTRODUCTION

The possibility that lasers might be pumped by radiations usually associated with nuclear, rather than with electronic or optical sources, has been recognized and investigated for many years,^{1,2} but, until now, no significantly successful laser systems based on nuclear pumping have been developed. Nevertheless, the concept continues to have appeal because of inherent advantages that nuclear-pumped lasers (NPL) are believed to possess. Many concepts have been proposed for complete systems that would feature an NPL as the central component.^{1,3,4} Their proposers all emphasize that direct excitation of the laser medium by nuclear reaction energy would eliminate intermediate energy conversion and matching systems (Rankine cycle, generator, transformers, capacitors, flashlamps or accelerators, etc.), and that it would relieve the scaling limitations that presently limit electron-beam- and electrical-discharge-pumped gas lasers to small active volumes and apertures, while, correspondingly, it would increase the total light output

and enhance portability. These advantages would be especially convenient for space and military applications. The possibility of eventually developing hybrid systems, in which the nuclear reactor and the laser medium are an integral unit with which fission energy is directly converted into a beam of light, has even been discussed,^{5,6} and it has been suggested that this might circumvent thermodynamic constraints on the energy conversion process because of the low entropy content of coherent light.^{7,8}

Much of the early enthusiasm for NPLs has evaporated because an appropriate medium for the laser has been lacking. Although lasing has indeed been observed in several gases and gas mixtures, experimental results have generally been disappointing when measured against the initial expectations and the requirements of specific applications. Emphasis has shifted from lasing to incoherent light production because a nuclear-pumped flashlamp (NPFL) might be easier to develop, would have considerable utility, and might permit several optically-excitabile lasers to be pumped indirectly by nuclear radiations from a single reactor source.

GENERAL COMMENT

I was asked to make a theoretical appraisal of the status and significance of the recent work at Los Alamos on nuclear pumping in the noble elements, relating it to the general context of nuclear pumping research being done elsewhere, and to make recommendations. In this report, I have summarized the Los Alamos work as I have been given to understand it, assessed its apparent significance, pointed out a number of unresolved problems whose solution must precede the determination of its ultimate significance, and made recommendations for investigating them. The opinions and recommendations set forth in this report are solely mine.

Although until recently I was a skeptic, this work has convinced me that there is considerable potential for both NPL and NPFL devices. Until recently, most NPL research was with gases known to lase when excited by flashlamps or by electrical discharges.¹ In those gases, when so excited, the energies of the bombarding electrons are relatively low. Those atomic and molecular species for which efficient conversion of the high kinetic energy of fast ionizing particles into lasing channels can be expected on theoretical grounds may be quite distinct from those best suited for conventional pumping methods. Moreover, most NPL research has been conducted under necessarily restricted experimental circumstances, which make it difficult to undertake detailed and accurate investigations of excitation mechanisms and even to identify the transient active species.

Recent work at Los Alamos offers hope not only that the liquefied noble-gas elements (LNE)* are appropriate for efficient nuclear pumping, but that a nuclear pump is the best way to excite them, because a remarkably high efficiency for exciting optical radiation then is coupled with the high penetrating power of nuclear radiations. However, not enough is known to permit a final conclusion.

In the following section, reasons for expecting high efficiency in both liquid and gaseous noble-element systems are briefly presented. Recent experimental work at Los Alamos that has confirmed this expectation will be described in a technical report** and in an article for

*The term "noble element" is preferred to the more commonly employed term "rare gas." Many gases other than column-VIII elements are rare. "Inert gas" is also inappropriate. Moreover, the term "liquid rare gas" is particularly awkward and should be avoided—a gas is a liquid as well only at its critical point!

**The experimental work has been described in an early draft of Ref. 9.

journal publication that are in preparation.⁹ In this report, I discuss the significance and the limitations of these findings and the questions that remain unanswered. Finally, I suggest further investigations into the behavior of LNE light sources needed before their ultimate potential for nuclear-pumped systems can be assessed and before realistic considerations of applications are possible.

EXCIMER AND EXCIPLEX LASERS

The excimer family of lasers^{10,11} is based on the formation of short-lived excited diatomic molecules (dimers) of the noble elements (NE) that dissociate immediately after transition to the ground state. It offers the prospect of directly excitable light sources, perhaps also of lasers, with which the conversion of nuclear radiations into optical radiation may be far more efficient than in any other system so far considered for NPL application.

In many gas-laser transitions, the terminal state must be de-excited by diffusion to the walls of the discharge tube, which must, therefore, be of limited diameter. In excimers, on the other hand, the terminal state is promptly destroyed upon its formation, because the interatomic potential of two ground-state NE atoms is repulsive. The transverse dimension is then limited only by the onset of losses from superfluorescence, and relatively penetrating pumping radiation can then be utilized more efficiently.

To a theoretically high conversion efficiency, approaching 50%, is added the possibility of a self-critical nuclear reactor-laser system in which fissile fuel in a volatile or soluble compound (e.g., UF_6) is dissolved in the NE. Finally, exciplex systems,^{10,11} in which wavelength shifting is accomplished by using additives, such as halides, oxides, or sulfides, that can be collisionally excited by the excimers, may permit flexibility in the choice of operating wavelength without great loss in overall efficiency.

Liquid (LNE) rather than gaseous NE offers further advantages. The higher density of the liquid permits full exploitation of the penetrating power of neutrons and gamma radiation and invites consideration of the development of self-critical solutions or suspensions of fissile materials in the LNE. Although recent experiments¹² and analyses¹³ indicate that UF_6 effectively quenches light production in gaseous xenon if it is

present in concentrations too low for fission-chain criticality, I suspect that its quenching action in the liquid phase may be strongly suppressed.

EXCITATION MECHANISMS IN NUCLEAR PUMPING OF EXCIMERS

In gas lasers pumped by electrical discharges, electrons, most having energies below ionization potential of the medium but temperatures considerably higher than the gas, together with ions and excited atoms, interact to generate excitation above inversion of laser states in atoms or molecules. The detailed reaction chains by which electron kinetic energy is transformed into excitation of the lasing species¹⁴ are complicated and, except for the NE lasers, have little relevance to the present discussion. It suffices to state that departure from thermal equilibrium between the electrons and the gas molecules is an essential common feature, and that ordinarily only a small fraction of the electron population in the plasma of a glow discharge is in the energy range that contributes to the excitation — in fact, much of it acts to de-excite the active states. Efficiencies are therefore low ($\leq 2\%$) except in unusual cases (e.g., $\text{CO}_2\text{-N}_2$).

With nuclear sources, the distributions in energy of those electrons that are the principal agents for excitation of atoms are quite different from those found in electrical discharges, and the electrons that are approaching equilibrium are much cooler than in the electrical field of a discharge. Hence, a laser medium that can be excited efficiently with an electrical discharge may not be efficiently pumped with nuclear radiation, and vice versa. This is obviously true of optically pumped lasers.

Figure 1 illustrates the initial step and the final results of long chains of energy-degradation processes by which radiations from a fission reaction are ultimately converted into light and heat.¹⁵ The nascent nuclear radiations—fast fission fragments, neutrons, and gamma radiation—all (except for slow neutrons from thermal reactors) have kinetic energies far higher than those found in glow discharges. Collisions of the fission fragments give rise to rapidly recoiling ions, fast electrons, and x or γ rays. Collisions of the fast neutrons generate recoiling ions, inelastic-scattering gamma rays, and, ultimately, slow neutrons that, when captured, give rise to gamma radiation. All x and γ radiation is degraded by photoelectric and Compton processes (with a minor amount of positron-electron pair production),

creating fast electrons and ions. Thus, all the incident radiations give rise to fast electrons that, as they degrade to lower energy, are replaced by slower electrons, ions, excited atoms, and x rays. The proportion of ions to excited atoms that finally results is nearly independent of the primary electron energy when the latter greatly exceeds the ionization potential of the atom, and it is also relatively insensitive even to the nature of the incident radiation.¹⁶

Thus, most of the energy that is initially deposited from a nuclear source, regardless of primary composition, is channeled through fast electrons, which ionize and excite atoms in nearly constant proportions, given roughly by the energy balance

$$WN_1 = N_1I + N^*E^* + N_1E_c ,$$

where

W = mean energy expended per ion pair formed

I = ionization potential

E^* = average energy of excitation

E_c = average kinetic energy imparted to the electron

N_1 = number of ion-pairs

N^* = number of excited atoms formed by the radiation.

It is well-known¹⁶ that W is nearly the same multiple of the ionization potential for all kinds of ionizing radiations and in all the noble gases; this also is approximately true of the noble-element liquids as well, although much less is known about them. For example, in electron-bombarded gaseous xenon $W = 22.1$ eV and in liquid xenon (LXe) $W = 15.6$ eV.¹⁶ The ionization potential is $I = 12.1$ eV. In an average "ionizing collision" in the gas, the transferred energy is partitioned in the approximate proportions: 0.62 ions, 0.20 excited atoms, and 0.18 subexcitation electrons.⁹

Figure 2 illustrates the chain of collision processes in a pure noble element^{10,11,14} that, in first order, determine the density of excimer states under nuclear irradiation, together with processes that tend to deplete them. These reactions are labeled

(1) primary ionization and

(2) primary excitation.

They compete in the proportions noted above and are followed by

(3) ionization of the excited atoms by fast electrons

(4) three-body association of ions with neutral atoms to form diatomic molecular ions, followed promptly by either

(5) further association to form trimer ions, or

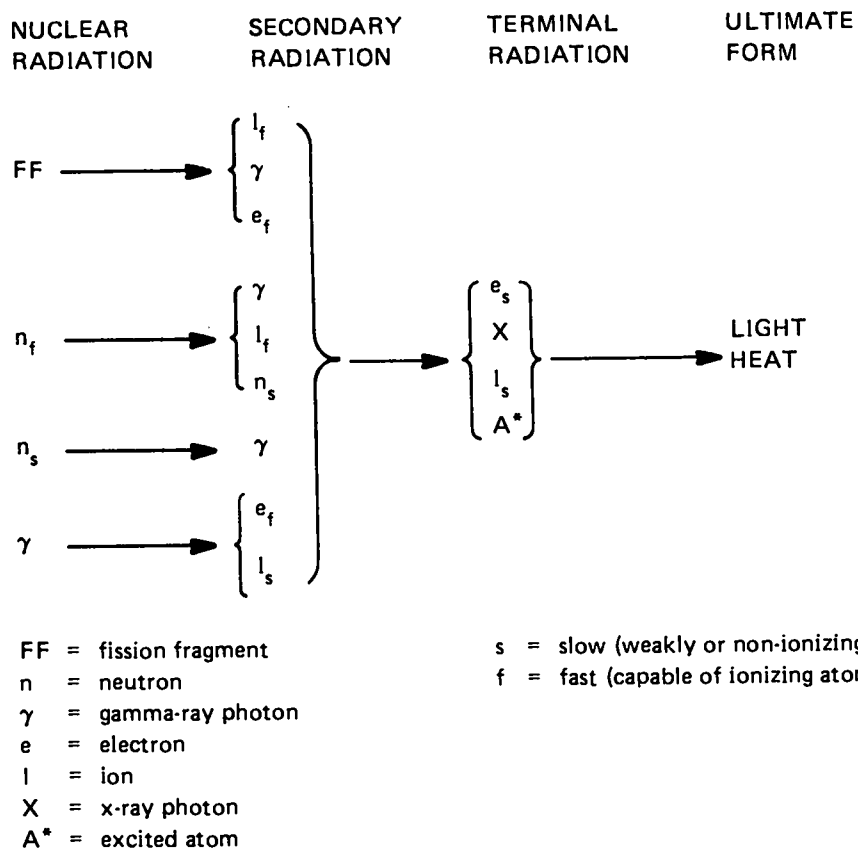

Fig. 1.
 "Nuclear radiations": their secondary and final products.

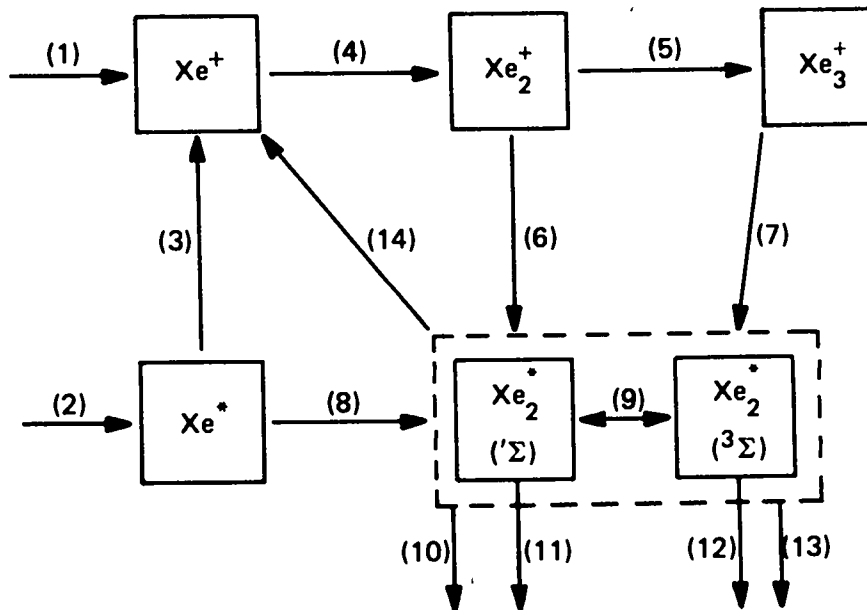

Fig. 2.
 Energy flow in irradiated xenon.

- (6) dissociative recombination of electrons with dimer ions, or
- (7) dissociative recombination of electrons with trimer ions.

Reactions (6) and (7) together with

(8) three-body association of the excited atoms lead to formation of the excimer Xe_2^* . Reactions (6) and (7) can form the excimer either directly or via Xe^* .

The excimers occur in both singlet and triplet sub-states, the latter being very slightly lower in energy. The shorter-lived (~ 5 ns) singlet state, rather than the 96-ns triplet state, is believed to be the lasing species;¹⁰

- (9) collisions with low energy electrons tend to mix the singlet and the triplet populations and
- (10) can de-excite either one.

The singlet and the triplet populations are also depleted by

- (11) and (12) photon emission (the desired result),
- (13) quenching by impurities, and
- (14) mutual annihilation by excimer-excimer collision to form an ion and a neutral atom.

The concentrations of the excimer states, established by competition of formation and destruction, therefore are nonlinear functions of the total atom density and of the intensity of irradiation, and they are sensitive to impurities that interact directly with the excimer or that modify the electron spectrum. Nonlinearities are known¹⁰ to become very important in excimer gas lasers as ion-pair densities approach 10^{16} cm^{-3} .

ESTIMATED EFFICIENCY FOR LIGHT PRODUCTION

Using the known values for W and I together with known or estimated rate constants for the various reactions in xenon, and assuming that each reaction comes rapidly into equilibrium with a slowly varying nuclear source, it can be shown⁹ that the average energy expended in the formation of a Xe_2^* excimer as a result of collisions with fast electrons, reactions (1) and (2) in Fig. 2, should approach 55% of the total energy expended by the electrons. This estimate, which assumes negligible quenching and annihilation, should be of the correct order of magnitude if the xenon is pure and the excitation level is not too high. It is a consequence of the partition of energy in collisions, noted above, together with the fact that part of the energy used for ionization that is given to electrons can continue the process

because W is insensitive to the electron energy so long as it is appreciably higher than I . The detailed reactions, their rate constants, and the mathematical details leading to the quoted result are given in Ref. 9.

If the excimers relax primarily by photon emission and if the medium is transparent, the efficiency for light production (LPE) should be equally high. On the other hand, the efficiency for lasing may nevertheless not be high because that depends on the ratio of populations in the singlet and the triplet states. Moreover, collisional relaxation processes compete with photon emission.

The chain of formation reactions includes both two- and three-body processes, the rates of which are density-dependent. Because of recombination and attachment reactions [especially if electron scavengers (UF_6 !) are present], the electron density is not necessarily related linearly to the intensity of excitation. Therefore, the expectations raised by this high estimate of light-production efficiency must be confirmed by experiments.

PECULIARITIES OF THE LIQUID PHASE

Let us note certain distinctive features of the liquid phase that may have an important bearing not only on the theoretical analysis but also on the experimental procedure.

Because the W -value for LXe is considerably lower than for the gas,¹⁶ a smaller proportion of the injected energy enters in the form of ionization; nevertheless, nearly all of it is still channeled through the excimer states. Thus, the LPE depends primarily on the competition of radiative and nonradiative modes of excimer de-excitation, so that we might expect comparable efficiencies for both liquid and gaseous media.

Considerable difference in behavior may be expected, however, for the secondary reactions involving diffusion, which is less rapid in the liquid⁹ than in the gas. In the high density and low temperature of the liquid, two- and three-body processes involving xenon atoms will be enhanced, but quenching reactions with impurities and transfer of excitation to additives will be inhibited (e.g., by clustering of xenon atoms around UF_6^- ions or other impurities). At a given level of excitation, excimer-excimer annihilation also may be less important in the liquid than in the gas. On the other hand, absorption of the emitted photons by transient ground-state dimers will be more probable in the liquid. Enhancement of

some and suppression of other reactions could lead to behavior at variance with that expected on an assumption, made above, that all reactions come into equilibrium rapidly.

TRACK DENSITY EFFECT

The high density of LXe can also enhance sensitivity of the LPE to the microscopic spatial distribution of the primary radiation, so that two different primary radiations at the same average intensity do not form the isomer with equal probabilities.¹⁷ Consider gamma radiation and fission fragments. The former interact throughout an extended volume, creating fast electrons of low ionizing power and long range. Thus, they excite the medium essentially homogeneously. Fission fragments, on the other hand, create extremely brief and locally intense excitation in the form of "tracks," within which reactions among excited species go to completion far more rapidly than a volume-averaged model⁹ would predict. In the gas, the tracks rapidly are smeared out by diffusion: in the liquid, they will persist. Inside the track, nonlinear processes are emphasized and steady-state conditions may not be attained. Moreover, inhomogeneity of excitation is accompanied by inhomogeneity of refractivity. Inhomogeneity on a scale comparable with the optical wavelength degrades the optical quality of the medium—a problem of concern for lasing, if not for light production. With fission or alpha particle excitation, observations that lasing yields quickly saturate as gas density increases^{*.2.18} may be accounted for, at least in part, by the track-like nature of the primary excitation. I suggest the term "track-density effect" for this hypothetical phenomenon.

A final comment concerns a widely used technique for determining the energy deposited in a confined medium by a nuclear source burst, by measuring the accompanying pressure transient.¹⁹ This assumes that all the energy deposited appears promptly in kinetic form (heat) rather than as photons radiated to external receivers or as internal energy of excited states. This assumption is obviously untenable when the LPE is of the order of 50%. The pressure transient might still be used as a check on the energy balance in the case of gaseous media, but it is, in any case, inadvisable to rely on it in the liquid, where strong and possibly destructive shock waves may be generated.

*See Fig. 16 of Miley, Ref. 2, and comments relative to it in the text.

THE LOS ALAMOS EXPERIMENTS

An experiment to measure the efficiency for light production⁹ of LXe was conducted at GODIVA IV, an enriched-metal-alloy fast burst reactor that, when driven to a reactivity of about \$0.06 above prompt critical, produces a temperature-quenched burst of fast neutrons and gamma rays. The neutron bursts have a full-duration-at-half-intensity of 40 μ s; the gamma burst is much longer owing to delayed gamma-ray emission. Each full-intensity burst generates, on the average, 5.4×10^{16} fast neutrons (fission spectrum) and 7.9×10^3 J of gamma radiation with an average photon energy of 1.5 MeV. Bursts can be repeated only after cooling periods of at least 2 h.

Two cells, one for liquid and the other for gaseous xenon, were disposed symmetrically in the median plane at 30 cm from the center of the reactor core. Light generated in either cell was observed with calibrated photodiodes and, occasionally, with a monochromator and an optical multichannel analyzer located outside the 32-in. concrete reactor shield and enclosed in additional lead shielding. All operations were performed remotely from a control area 400-m distant. Access to the reactor enclosure was restricted during the cooling period because of high ambient radiation levels.

Both fission-fragment and gamma-ray excitation were studied. Uranium-coated foils in the cells served as internal sources of fission fragments. Uncoated foils gave only the externally incident-gamma effect, which was subtracted from the with-uranium data to determine the fission-fragment excitation alone. In the gas cell, without uranium, intensity of vacuum ultraviolet (vuv) increased linearly with gas pressure in the entire 10-100 psia range investigated. With uranium, at pressures above 10 psia, where all fragments were stopped in the gas, the light-output curve was also linear and parallel to the no-uranium curve,⁹ but displaced by a constant interval. The constant spacing of the two curves above this critical pressure, at which all fragments were stopped in the gas, is the full fission-fragment contribution. Its independence of pressure suggests that there was no observable track-density effect in xenon gas at the pressures reached in the experiment.

The experimental difficulties of working with a fast burst reactor (limited access, inflexibility, low repetition rate, and inefficient geometry) were compounded by the necessity for absolute measurements of energy carried in the form of dissimilar radiations; that is, of the energy absorbed from gamma radiation, the energy lost by

fission fragments, and the energy emitted as vuv radiation in the vicinity of 175 nm, characteristic of Xe_2^* . Calibrations were therefore of extreme importance.

The gamma-ray fluence was determined calorimetrically using a differential thermocouple that compared the temperature rises accompanying simultaneous irradiation of aluminum and lead blocks.

The optical fluence was measured with photodiodes that were compared against a standard vuv photodiode previously calibrated at the National Bureau of Standards. Corrections for geometry and window transmissions were made. The spectrum of the optical radiation was checked to confirm that it was indeed Xe_2^* emission, and its time-dependence was shown to agree with that of the primary reactor irradiation.

The fission energy deposition was calculated from the beta activity of fission products induced by neutrons in an aluminum-uranium alloy wire. One absolute determination was made. After each reactor burst, the activity induced in the wire was compared with that in the standardized case. From these measurements of the fission activity, the specific fission yield (as fissions/g U) induced by each neutron burst was calculated. To find the number of fissions per unit area in the uranium-coated foils and, from this, the total energy carried into the xenon, it was necessary to determine the mass of uranium per unit area of foil; this was done by counting the gamma-ray activity of the foils. Finally, correction was made for fast neutron flux depression by scattering in the liquid xenon.⁹

An alternative method based on calorimetry analogous to the gamma-ray measurements might be more direct; however, the aluminum wire technique has been well developed by long use at the GODIVA site.

RESULTS OF THE LOS ALAMOS EXPERIMENTS

The measured vuv light output (assumed isotropically emitted) was compared with the energy delivered to xenon in several series of experiments at different gas pressures, with the LXe, and at different reactor burst levels. The results⁹ were expressed as a light production efficiency, and their final averages are given in Table 1.

Input energies ranged from 0.2 to 10^5 W cm^{-3} . No evidence for nonlinearity was observed, nor, as noted above, was there any indication of a track-density effect in the gas phase. Although the W-value for the liquid is lower than for gaseous xenon, as noted above, the data did not suggest a difference of LPE.

The results are subject to rather large uncertainties that unavoidably accompany an experiment performed at a fast burst reactor. Still, they confirm the expectation from the postulated mechanisms that a nuclear-excited noble element is an unusually efficient medium for transforming nuclear radiation into vuv in both liquid and gaseous phases.

The uncertainties in Table 1 are not based on statistical spread in the results of a number of identical measurements; instead, they correspond to estimates of the uncertainty of calculating the energy deposition from the measured data (activities and pulse heights) in which experimental parameters varied over a wide range.⁹ The optical fluence measurements were subject only to random errors of primary calibration, window transmission, and geometry, although scattered light may have increased the photodiode readings. On the other hand, the energy-deposition measurements may contain systematic errors. For example, gamma-ray measurements in gaseous xenon may have been affected by neutron sensitivity of the differential calorimeter and by lack of electronic equilibrium with the walls of the reaction cell; those in LXe may include an unknown contribution from neutron moderation and capture in xenon. The fission energy measurements were indirect, and the calculations were based on assumptions about the neutron spectrum. The fission-fragment-induced light measurements are sensitive to the time-dependence of the gamma-ray signal that was subtracted to determine the fission contribution. There were indications of impurity effects in some of the measurements. The maximum levels of excitation with the available geometry are considerably lower than would be obtained in a system having optimum geometry (e.g., having the light-production cell within or integral with the reactor core).

The experiments show that at least one noble element in the liquid phase can be excited as efficiently by nuclear radiations from a reactor as by pure electron-beam excitation. In an NPFL, excitation is still by electrons, but they are generated as secondaries by other radiations throughout a larger volume than an external electron source can excite.

QUESTIONS RAISED BY THE LOS ALAMOS LNE EXPERIMENTS

Although the GODIVA results are significant in the development of an NPFL, much more work is needed,

TABLE I

MEASURED VALUES OF LIGHT PRODUCTION EFFICIENCY INDUCED BY REACTOR IRRADIATION OF XENON

| Primary Radiation | Gas | | Liquid | |
|-------------------|----------------|-----------|----------------|-----------|
| | Probable Value | Range | Probable Value | Range |
| Gamma Rays | 0.43 | 0.40-0.48 | 0.45 | 0.38-0.52 |
| Fission Fragments | 0.61 | 0.56-0.69 | 0.46 | 0.39-0.53 |

especially for investigating the effects of additives and impurities, before useful flashlamps or lasers can be designed.

- In the present measurements, which show strict linearity of light output vs input energy, the ratios of excited-state and neutral-atom densities are not particularly high ($<10^{15} \text{ cm}^{-3}$) in comparison with the densities achieved in electron-beam-pumped systems. How much higher can the excitation be raised before nonlinear processes, which are known to be important in gaseous xenon at about one order of magnitude higher excitations,¹⁰ begin to dominate the behavior in the liquid phase?
- The indication that there is no track-density effect on light production in the gas may not rule out its occurrence in the liquid phase. Moreover, although total light production may not be significantly changed by the effect, lasing may be seriously affected. I therefore continue to ask: How large is the track-density effect?
- That the liquid phase is characterized by limited diffusion and enhancement of three-body processes seems not to have affected the LPE in pure xenon, within the experimental accuracy. Will this also be true when impurities and additives are present? (There were indications of impurity effects in the GODIVA experiment.)
- Wavelength shifting by exciplex formation^{10,11} involves collisions of the excimers with molecules of appropriate additives (e.g., Kr_2^* with OCS to create KrS^* , etc.). Will efficient formation of the exciplex occur in the liquid phase?
- Quenching of excimer emission by UF_6 in gaseous systems has been shown, both experimentally¹² and theoretically¹³ to be due primarily to collisional

de-excitation by the UF_6^- ion. In the cold liquid, will collisional quenching be less effective than in the gas, thereby permitting addition of UF_6 to the liquid in concentrations that permit nuclear criticality?

- Will the electron scavenging propensity of UF_6 affect the singlet-triplet ratio favorably, unfavorably, or not at all?
- Will lasing be possible in the liquid phase? If so, can additives be found that will increase the lasing, or if not, the LPE efficiency, in addition to shifting the output wavelength?
- Are the effects of the various constituents of mixed reactor radiation (e.g., neutrons, fission fragments, and gamma rays) additive at higher levels of excitation?

In order to answer these and other questions that will continue to arise as research proceeds, one must be able to pump with pure radiations in pulses sufficiently brief for time-resolved measurements and at repetition rates that enable statistically precise data. One must identify transient species, measure their lifetimes, and determine the partition of energy among them by measuring branching ratios and reaction rate coefficients. Techniques must be developed for introducing and monitoring the concentrations of additives, removing impurities, and preventing deposition of additives onto walls and windows—problems that will call for ingenuity.

FINAL COMMENTS AND RECOMMENDATIONS

Until these questions have received satisfactory answers, further analysis of “systems” and “missions” would be premature. Systems analyses should await

resolution of the questions of laser vs flashlamp; of the range of linearity; and of the effects of additives, particularly UF_6 , halides, and sulfides. These questions profoundly affect the nature, the size and weight, the output wavelength and intensity, and, indeed, the very feasibility, or at least the practicability, of nuclear pumping. Until then, systems studies are an exercise in irrelevance.

There must be a transition in the character of NPL research, which has heretofore always centered on existing research reactor facilities and has featured trials of various gaseous mixtures to find candidates that would lase efficiently under nuclear excitation. I believe the long-sought candidate has been found; confirmation of this belief is needed along with increased understanding of liquid noble element behavior. Fast burst reactors are neither necessary nor appropriate to this new phase of NPL research. They afford no flexibility in the composition of their output radiations (other than by differential attenuation); produce bursts too prolonged for kinetics studies; and present the constraints of security, limited access, high background, bulky shielding, criticality, and low repetition rate. Now that it has been demonstrated that LNE systems are well-suited to efficient nuclear excitation, emphasis should shift from qualitative demonstration of light production to quantitative understanding of conditions under which each type of nuclear radiation can most efficiently excite optical emission, including the effects of additives and geometry. In particular, the kinetics of the various reaction chains that lead toward or away from the states active in lasing or light production must be studied in time-resolved measurements with "clean" radiation sources, both photon and particle. The experiments should be accompanied by theoretical analyses. In brief, physics, rather than engineering, must be emphasized.

LNE systems are also under investigation in other programs at Los Alamos in which ionization is used to generate electrical signals for radiation detection.* Close liaison between groups working in both fields would be of mutual benefit.

It is recommended that an intense pulsed source of near-relativistic electrons (Febetron[®]) be used to generate fast electrons, x-rays, or vuv photons. This would permit clear time-resolved experiments in the liquid noble elements with good statistical accuracy and improved flexibility. For example, the photolysis of additives such

*Private communication from D. Drake.

as OCS could be studied with vuv light flashes excited in a separate xenon-filled cell. Gamma-ray excitation at modest intensities could be duplicated by using the electron beam to generate x-rays, but, for most of the research, the beam electrons should be used directly, after the problem of providing an entrance window to a liquid cell has been overcome. They will be the most useful research tool for developing quantitative information on liquid-phase behavior and on the effects of additives.

Although electron beam excitation can achieve the energy densities typical of fission tracks, it does not reproduce their inhomogeneity. A separate study of this question necessarily requires a nuclear source, but not a burst reactor. The Weapons Neutron Research facility at the Los Alamos Meson Physics Facility is a source of brief, intense pulses of fast neutrons that might be used for inducing fission-fragment radiation. A heavy-ion accelerator would also be suitable.

Although quantitative research requires other than burst-reactor sources, the final stages of NPL development must employ a nuclear reactor source rather than an array of laboratory sources. The reactor should permit maximum flexibility and be compatible with the requirements of the optical system it excites. The SKUA reactor, which is designed to provide a large central hole for irradiations in the highest possible neutron and gamma-ray flux,²⁰ should be completed and made available for final proof-of-performance experiments short of tests with explosive nuclear sources.

Except for a heavy-ion accelerator, all of the facilities essential to a continued program of basic investigations leading to a final demonstration of LXe and NPFL performance are available at Los Alamos.

ACKNOWLEDGMENTS

I am grateful to W. Hughes for making copies of early drafts of Ref. 9 available in advance of its publication. I appreciate discussions with I. Bohachevsky, D. Drake, W. Hughes, W. Maier II, R. Malenfant, C. Mansfield, and W. Talbert. I thank N. Jalufka and R. DeYoung of the NASA-Langley Research Center for their hospitality and enlightening discussions of the NPL problem. The support of NASA through the Langley Research Center, monitored by C. Watson, DoD Programs, is also acknowledged.

REFERENCES

1. D. H. Nguyen and A. E. Fuhs, Report of Workshop on Direct Nuclear Pumping of Lasers, Monterey, California, April 6-8, 1976.
2. G. H. Miley, "Direct Nuclear Pumped Lasers—Status and Potential Applications," in *Laser Interaction and Related Plasma Phenomena*, Vol. 4A, H. J. Schwarz and H. Hora, Eds. (Plenum Press, New York, 1977), pp. 181-228.
3. K. Thom and F. C. Schwenk, Preprint 77-513, "Gaseous Fuel Reactor Systems for Aerospace Applications," AIAA Conference on the Future of Aerospace Power Systems, St. Louis, Missouri, March 1-3, 1977.
4. G. H. Miley, E. Greenspan, and J. Gilligan, Int. Conf. Emerging Nucl. Energy Syst. 2nd, Lausanne, Switzerland, 1980.
5. R. T. Schneider, K. Thom, and H. Helmick, Proc. Int. Astronaut. Congr. 26 (Pergamon Press, New York, 1976), pp. 45-59.
6. L. I. Gudzenko, I. S. Slesarev, and S. I. Yakovlenko, "Proposed Nuclear Laser Reactor," Sov. Phys. Tech. Phys. 20, 1218-1221 (1975).
7. R. H. Fowler, *Statistical Mechanics*, 2nd Edition (Cambridge University Press, New York, 1935), Chap. VI.
8. D. ter Haar, "On the History of Photon Statistics," Proc. Int. Sch. Phys. Enrico Fermi 42, 1967, *Quantum Optics*, R. J. Glauber, Ed. (Academic Press, New York, 1969), pp. 1-14.
9. W. M. Hughes, J. F. Davis, W. B. Maier, and R. F. Holland, Los Alamos National Laboratory report (to be issued).
10. M. H. R. Hutchinson, "Excimer and Exciplex Lasers," Appl. Phys. 21, 95-114 (1980).
11. C. K. Rhodes, Ed., *Excimer Lasers* (Springer-Verlag, Berlin, 1979).
12. F. Hohl, R. J. DeYoung, and N. W. Jalufka, "Recent Advances in NASA Nuclear-Pumped Laser Research," Trans. Am. Nucl. Soc. 34, 808 (1980).
13. H. A. Hassan, "UF₆-Pumped Laser Systems," Trans. Am. Nucl. Soc. 34, 811-812 (1980).
14. C. W. Werner, E. V. George, P. W. Hoff, and C. K. Rhodes, "Radiative and Kinetic Mechanisms in Bound-Free Excimer Lasers," IEEE J. Quantum Electron. QE-13, 769-783 (1977).
15. S. Glasstone and R. Sesonske, *Principles of Nuclear Reactor Engineering*, 2nd Edition, (Van Nostrand Reinhold, Princeton, New Jersey, 1967), Chap. 10.
16. "Average Energy to Produce an Ion Pair," Int. Comm. on Radiation Units and Measurements report ICRU-31 (1979).
17. G. C. Baldwin, Los Alamos National Laboratory memorandum P-3/79-42, February 7, 1979.
18. N. W. Jalufka, R. J. DeYoung, F. Hohl, and M. D. Williams, Proc. Conf. Uranium Plasmas Appl. 3rd, Princeton University, Princeton, New Jersey, 1976.
19. G. C. Baldwin, Los Alamos National Laboratory memorandum P-3/79-55, February 13, 1979.
20. J. D. Orndoff, H. C. Paxton, and T. F. Wimett, "Safety Analysis of the Los Alamos Critical Experiments Facility: Burst Operation of SKUA," Los Alamos National Laboratory report LA-6206, Vol. II, Addendum (Rev. 1) (December 1980).

Printed in the United States of America
 Available from
 National Technical Information Service
 US Department of Commerce
 5285 Port Royal Road
 Springfield, VA 22161
 Microfiche \$3.50 (A01)

| Page Range | Domestic Price | NTIS Price Code | Page Range | Domestic Price | NTIS Price Code | Page Range | Domestic Price | NTIS Price Code | Page Range | Domestic Price | NTIS Price Code |
|------------|----------------|-----------------|------------|----------------|-----------------|------------|----------------|-----------------|------------|----------------|-----------------|
| 001-025 | \$ 5.00 | A02 | 151-175 | \$11.00 | A08 | 301-325 | \$17.00 | A14 | 451-475 | \$23.00 | A20 |
| 026-050 | 6.00 | A03 | 176-200 | 12.00 | A09 | 326-350 | 18.00 | A15 | 476-500 | 24.00 | A21 |
| 051-075 | 7.00 | A04 | 201-225 | 13.00 | A10 | 351-375 | 19.00 | A16 | 501-525 | 25.00 | A22 |
| 076-100 | 8.00 | A05 | 226-250 | 14.00 | A11 | 376-400 | 20.00 | A17 | 526-550 | 26.00 | A23 |
| 101-125 | 9.00 | A06 | 251-275 | 15.00 | A12 | 401-425 | 21.00 | A18 | 551-575 | 27.00 | A24 |
| 126-150 | 10.00 | A07 | 276-300 | 16.00 | A13 | 426-450 | 22.00 | A19 | 576-600 | 28.00 | A25 |
| | | | | | | | | | 601-up | † | A99 |

†Add \$1.00 for each additional 25-page increment or portion thereof from 601 pages up.