

0000-790795-2

LA-UR-79-2769

TITLE: SYMPATHETIC DETONATION

AUTHOR(S): Allen L. Bowman, Los Alamos Scientific Laboratory  
and  
David E. Richardson, Hercules Inc. 3516249

SUBMITTED TO: Proceedings of the Sixteenth JANNAF Combustion Meeting:  
Chemical Propulsion Information Agency  
The Johns Hopkins University/APL  
Attn: Ms. Debra S. Barnes  
Johns Hopkins Road  
Laurel, MD 20810

DISCLAIMER  
This document is prepared for the U.S. Government and is not to be distributed outside the U.S. Government. It is the property of the U.S. Government and is loaned to you. It and its contents are not to be distributed, copied, or reproduced in any form, by any means, without the express written permission of the U.S. Government. This document is prepared for the U.S. Government and is not to be distributed outside the U.S. Government. It is the property of the U.S. Government and is loaned to you. It and its contents are not to be distributed, copied, or reproduced in any form, by any means, without the express written permission of the U.S. Government.

MASTER

By acceptance of this article, the publisher recognizes that the U.S. Government retains a nonexclusive, royalty free license to publish or reproduce the published form of this contribution, or to allow others to do so, for U.S. Government purposes.

The Los Alamos Scientific Laboratory requests that the publisher identify this article as work performed under the auspices of the U.S. Department of Energy.

University of California



LOS ALAMOS SCIENTIFIC LABORATORY

Post Office Box 1663 Los Alamos, New Mexico 87545

An Affirmative Action/Equal Opportunity Employer

## SYMPATHETIC DETONATION\*

Allen L. Bowman  
Los Alamos Scientific Laboratory  
Los Alamos, New Mexico

David E. Richardson  
Hercules, Inc.  
Magna, Utah

### ABSTRACT

The results of a combined experimental and theoretical study of sympathetic detonation of VRO propellant are summarized. The extent of sympathetic reaction has been determined experimentally for different sizes and shapes of propellant. The experiments have been modeled numerically using the LASL reactive hydrodynamic code 2DE with Forest Fire burn rates. The critical separation distance for high-order detonation has been calculated for the cylindrical equivalents of 1-, 2-, and 3-inch cubes, and is in excellent agreement with experiment. The calculated behavior of the total system is shown with a computer-generated movie, and details of the pressures in the air gap and in the acceptor are presented.

### INTRODUCTION

A major problem in the handling and storing of munitions, and of explosive materials in general, is that of sympathetic detonation. We mean by this term the detonation of nearby explosive objects by the blast and/or debris from a primary explosion. Concern with the problem of sympathetic detonation has increased with the coming of rocketry and high impulse solid fuels that are being developed for propellants. These fuels are composed mainly of explosive substances.

The sympathetic detonation of solid rocket propellants is important at two different levels. Critical separation distances are needed to prevent the propagation of an explosive reaction from one motor to another. A second problem is the possibility of the propagation of an impact-initiated detonation through a series of propellant fragments in a damaged motor resulting finally in the detonation of the remaining propellant grain.

Hercules, Inc. (Bacchus Works) and the Thiokol Corporation have performed an extensive experimental study of the sympathetic detonation of selected rocket propellants under the cognomen "A Joint Venture." They have studied the effects of size, shape, damage, method of initiation, and other variables of possible importance. A concurrent effort at Los Alamos Scientific Laboratory is that of modeling the sympathetic detonation experiments numerically, thereby providing a better understanding of the details of the process and a capability for predicting results of future tests.

---

\*Work performed under contract N0003077 MD 77002 SSP0 13, Amend. 2

## EXPERIMENT AND MODEL

The concept behind these experimental studies of sympathetic detonation is that one propellant fragment ejected from a motor strikes a rigid target and reacts explosively. The energy from this reaction travels back toward the motor either directly or through a chain of propellant fragments. The test configuration is shown schematically in Fig. 1. The cube within

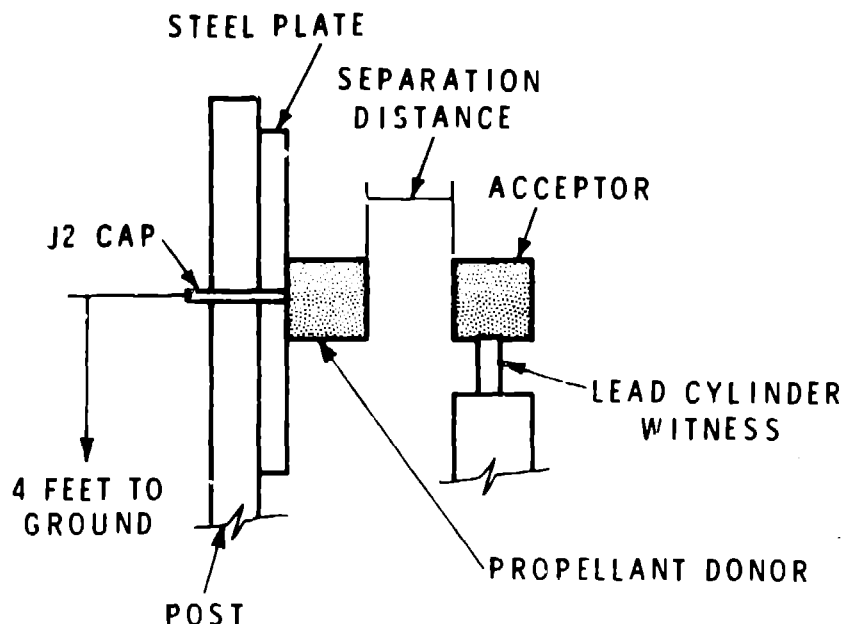

Fig. 1. Test setup for sympathetic detonation experiment.

which a detonation is first initiated is defined as the donor cube. The other cube, which is assumed to be affected by the detonation of the donor cube, is called the acceptor cube. The donor cube is backed by a steel plate, and is initiated by a J-2 cap inserted through a hole in the plate. The steel backing plate simulates hardware being impacted and directs the energy of reaction as would a rigid impact target. The initial experiments were with 3/4- to 2-inch cubes. These were extended to larger cubes and to cylinders.

Lead witness cylinders were placed underneath each acceptor to indicate the relative strength of the acceptor reaction. The high-order detonation was calibrated by a witness cylinder placed beneath the donor. A spacing of 1/8 to 1/4 inch was maintained between cylinder test samples and the witness cylinders to avoid possible impedance mismatch problems. The cubes were placed directly on the lead cylinders. The sizes of the lead witness cylinders were; 1-inch diameter by 4 inches for samples <10 pounds and 2-1/8-inch diameter by 10 inches for samples >10 pounds. The strength of sample reaction is defined as follows: (1) high-order detonation (HOD) - damage to witness cylinder equal to the calibration; (2) low-order detonation (LOD) - damage to the witness cylinder is significantly less than for HOD, but no

**BLANK PAGE**

propellant is recovered; (3) low-order explosion (LOE) - damage to the witness cylinder is less than for LOD, and some propellant is recovered; (4) no explosive reaction (NR) - no damage to the witness cylinder and most of the propellant is recovered. Typical post-experiment witness cylinders that illustrate such effects are shown in Fig. 2. The experimental arrangement is shown in Fig. 3.

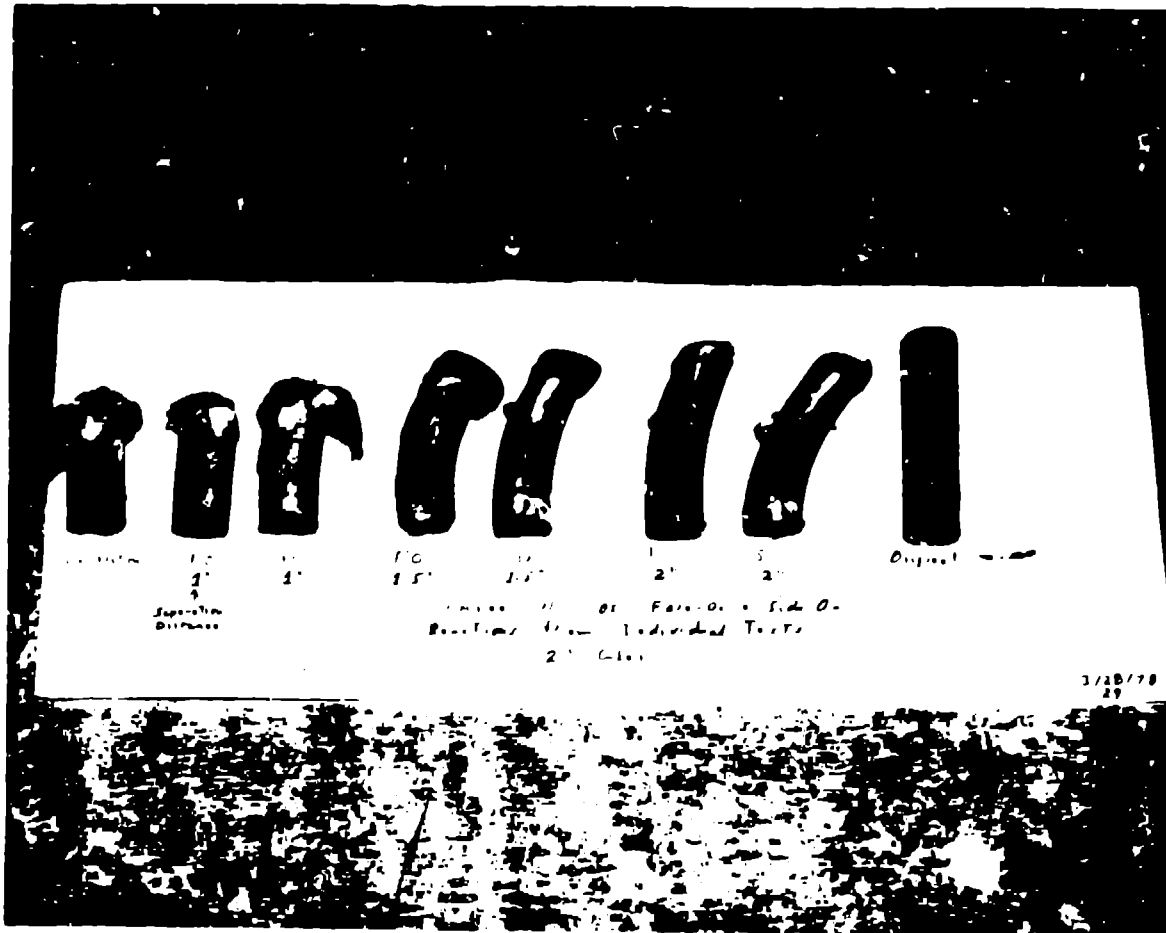

Fig. 2. Lead witness cylinders from sympathetic detonation experiments, 2-in. cubes of VRO. Numbering from the left, Nos. 1 and 2 show a high-order detonation, 3 is marginal, 4-7 show the results of lesser reactions, and 8 is an original for comparison.

Continuous velocity probes and Manganin gauges were mounted on the front and back surfaces of the large cylindrical acceptors tested at Hercules, Allegheny Ballistics Laboratory (ABL) and for the 2-in. diameter by 6-in. long acceptors tested at Hercules, Bacchus. This instrumentation is still being perfected. Two pairs of overpressure gauges were used on all tests where the total weight of donor and acceptor exceeded 10 pounds. Two gauges 1 foot apart were mounted at 15 or 25 feet from the center of gravity (CG) of the acceptor on the extension of the axis connecting donor and acceptor. Similar gauges at the same distances were mounted on a line passing through the acceptor CG and perpendicular to the axis connecting

**BLANK PAGE**

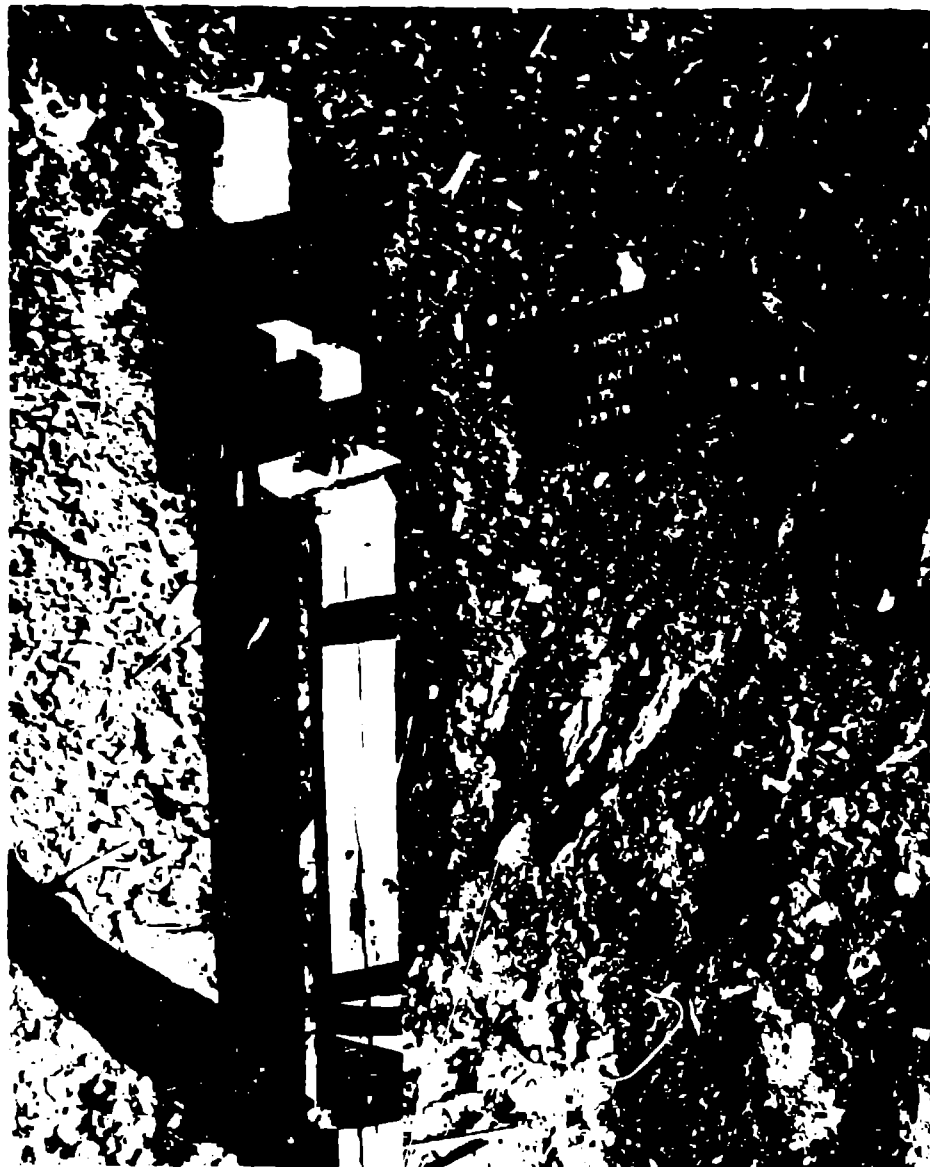

Fig. 3. Test setup for sympathetic detonation experiment (cubes).

donor and acceptor.

The shock pressures impinging on cubical acceptors at certain critical separation distances which produced low-order detonation were estimated in separate tests using expendable pressure gauges (EPG) mounted face-on in a  $\frac{1}{2}$ -in. thick plastic sheet at the measured separation distance for which low-order detonation was achieved. High speed movies at 6,000, 8,000, and 32,000 frames/sec., and documentary film were taken of the large cylinder and 8-in. cube tests at Thiokol. Still photographs were taken of the test setups, recovered propellant, and lead witness cylinders at Bacchus, ABL, and Thiokol.

**BLANK PAGE**



The computation of sympathetic detonation behavior was performed with the two-dimensional Eulerian reactive hydrodynamic code, 2DE,<sup>1,4</sup> using the Forest Fire burn rate.<sup>2,4</sup> The 2-in. cubes of the experiment were modeled by equivalent cylinders, 2.8678-cm radius and 5.0738 cm long, with a 0.002% difference in volume and a 0.1% difference in surface area of the matched faces. Calculations are described for cubes which were in fact made with these equivalent cylinders. The model geometry is shown in Fig. 4. The cap initiation was modeled by an initial hot spot of 0.8824-cm radius and length.

The same model has been used for experiments with 1- and 3-in. cubes by changing the cell dimensions. It has also been used without the steel backing in order to determine the effect of the plate. The effect of impact initiation of the donor cube has been studied by eliminating the hot spot and giving the plate or the donor cube an initial velocity. The flying plate experiment is modeled by giving the plate an initial velocity. The donor cube is given an initial velocity in an "end-on" approximation of the actual shotgun-type experiment in which the acceptor sample is located to the side.

#### RESULTS AND DISCUSSION

The sympathetic detonation throw distance is defined as the distance that a detonating donor can throw an explosive reaction to an acceptor. It is thus the separation distance for a given acceptor reaction. The effect of size on throw distance is shown in Fig. 5. The curve connecting the points representing the lowest throw distances for LOE is defined as the detonation threshold, i.e., a reaction below this curve would probably be a detonation (either LOD or HOD). The results were converted directly to spherical fragments, and the throw distance was fitted to the equation

$$T = 1.25r + 0.5r^2,$$

where  $r$  is the radius in inches of the spherical fragment and  $T$  is the throw distance in inches.

The throw distance of the detonation threshold is significantly greater for damaged acceptors. Experiments were performed with granulated propellant contained in paper cylinders, and with pieces of broken propellant that had

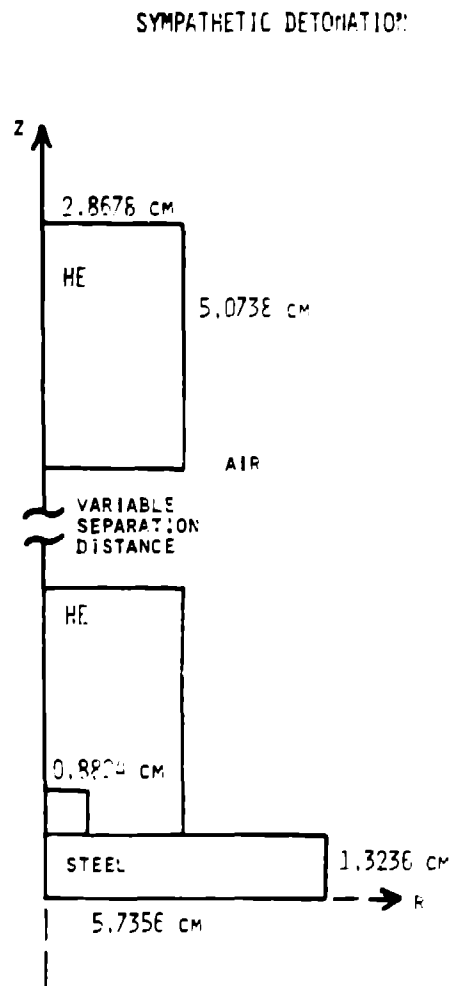

Fig. 4. Sympathetic detonation experiment.

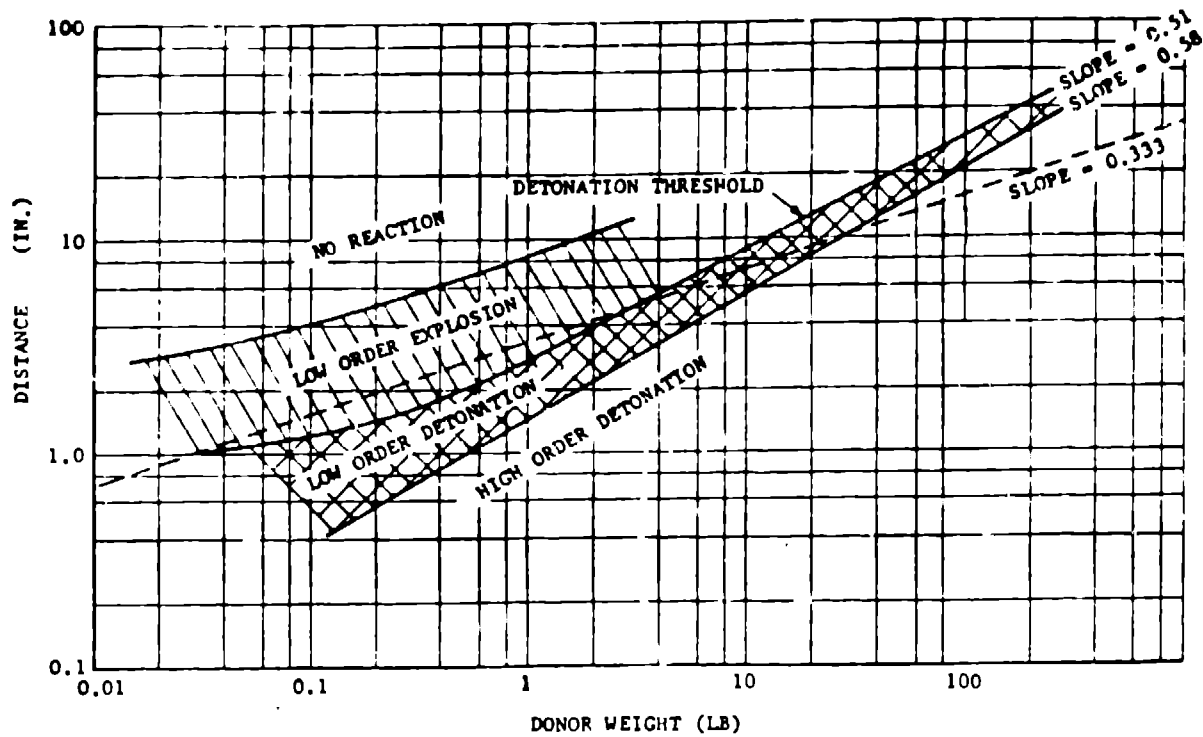

Fig. 5. Experimental throw distances for different size samples.

been recovered from other experiments. These results are summarized in Fig. 6.

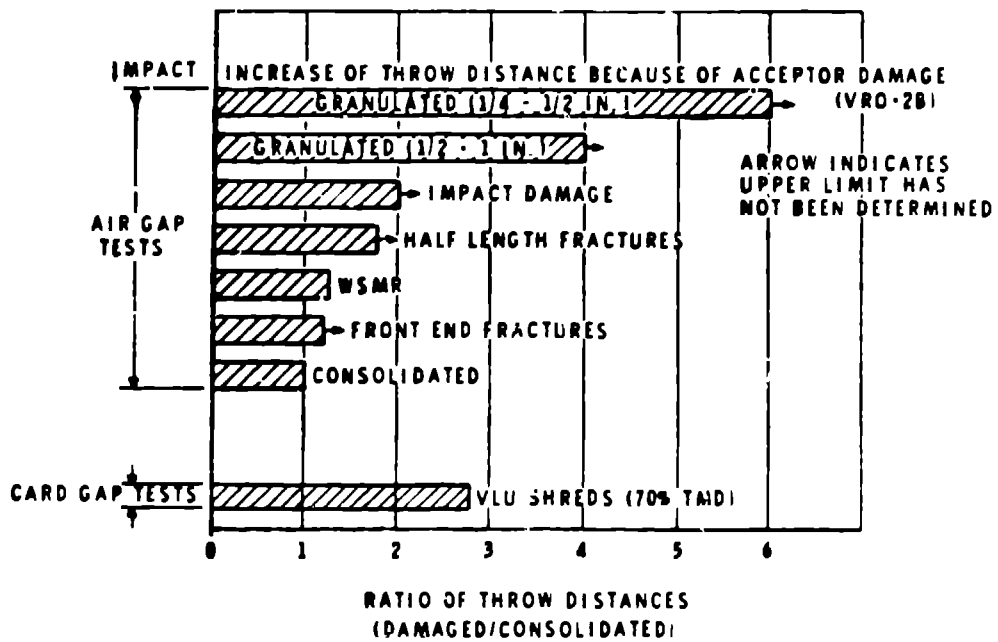

Fig. 6. Acceptor damage increases throw distances.

Sympathetic detonation experiments were performed with the acceptor to

the side (side-on configuration), rather than the standard end-on configuration. A dynamic side-on test was made with a gun-fired (70 mm) donor cylinder. Experiments were also conducted to study the effects of acceptor temperature, ignition of the acceptor (burning), and length-to-diameter ratio (L/D) of the donor. The results of these tests are summarized in Fig. 7.

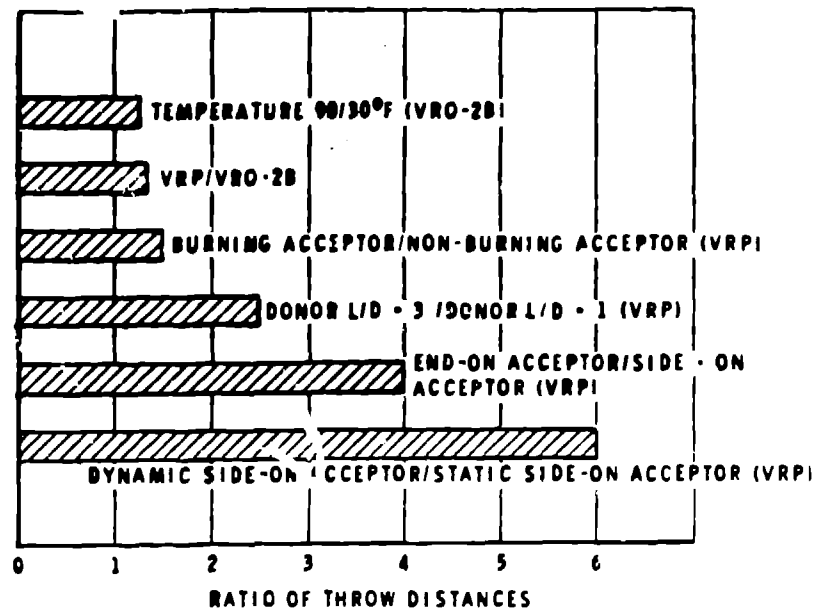

Fig. 7. Sympathetic detonation throw distances.

The detonation behavior of a VRO donor cylinder is portrayed in Fig. 8 by a series of contour plots of mass fraction, pressure and density. The mass fraction ( $W$ ) is defined such that  $W = 1$  for a solid and  $W = 0$  for a gas, with a continuous variation between these limits for a burning propellant. The calculated detonation pressure in the donor cylinder is steady at approximately 28 GPa, in good agreement with the C-J pressure of 29.2 GPa obtained from a BKW calculation.<sup>3</sup> The progress of the blast wave through the air gap and of the shock wave in the acceptor cylinder is shown by isopycnic plots in Fig. 9. The initiation and propagation of a detonation in the acceptor cylinder are shown by mass fraction contour plots in Fig. 10.

These figures describe the results of the calculation for simulated 2-in. cubes of VRO with a separation distance of 3.1 cm, but the general features of Figs. 8 and 9 are repeated in all calculations, with change of magnitude only. The length of run to detonation, which appears in Fig. 10 as the distance from the face of the cylinder to the first point of complete reaction ( $W = 0$ ), is found to increase with increasing separation distance to an abrupt transition to a very limited reaction ( $W > 0.9$ ).

The critical separation distance is defined as the midpoint between the longest gap for which detonation is observed and the shortest gap for which no detonation occurs. It appears from comparison with the experimental



Fig. 8. Detonation of the donor cylinder (VRO-simulated 2-in. cube). Contour plots of mass fraction, pressure (40-kbar interval) and density (0.1 g/cm<sup>3</sup> interval).

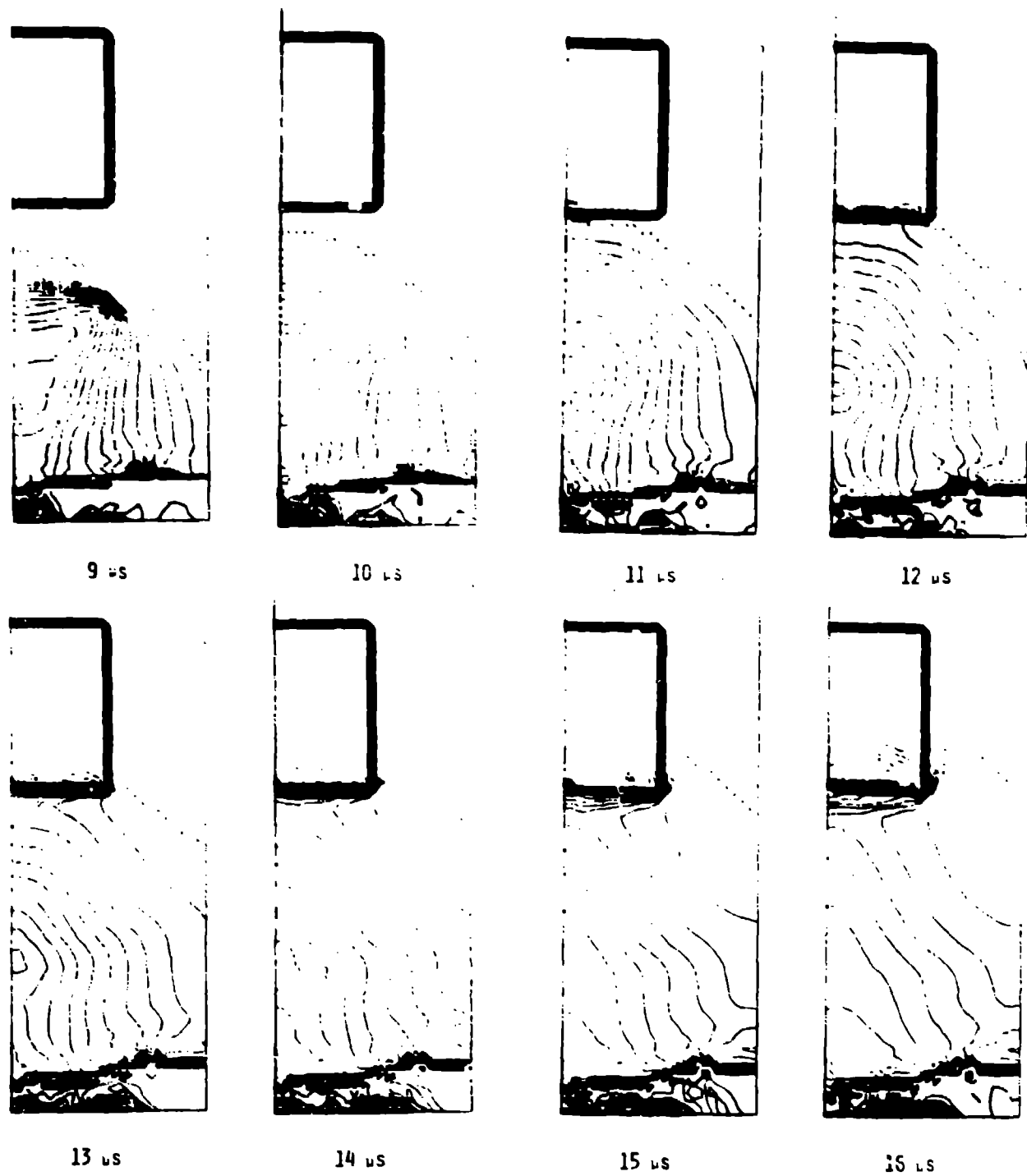

Fig. 9. Blast wave in the air gap; isopycnic contour plots ( $0.1\text{-g/cm}^3$  interval). VRO-simulated 2-in. cubes.

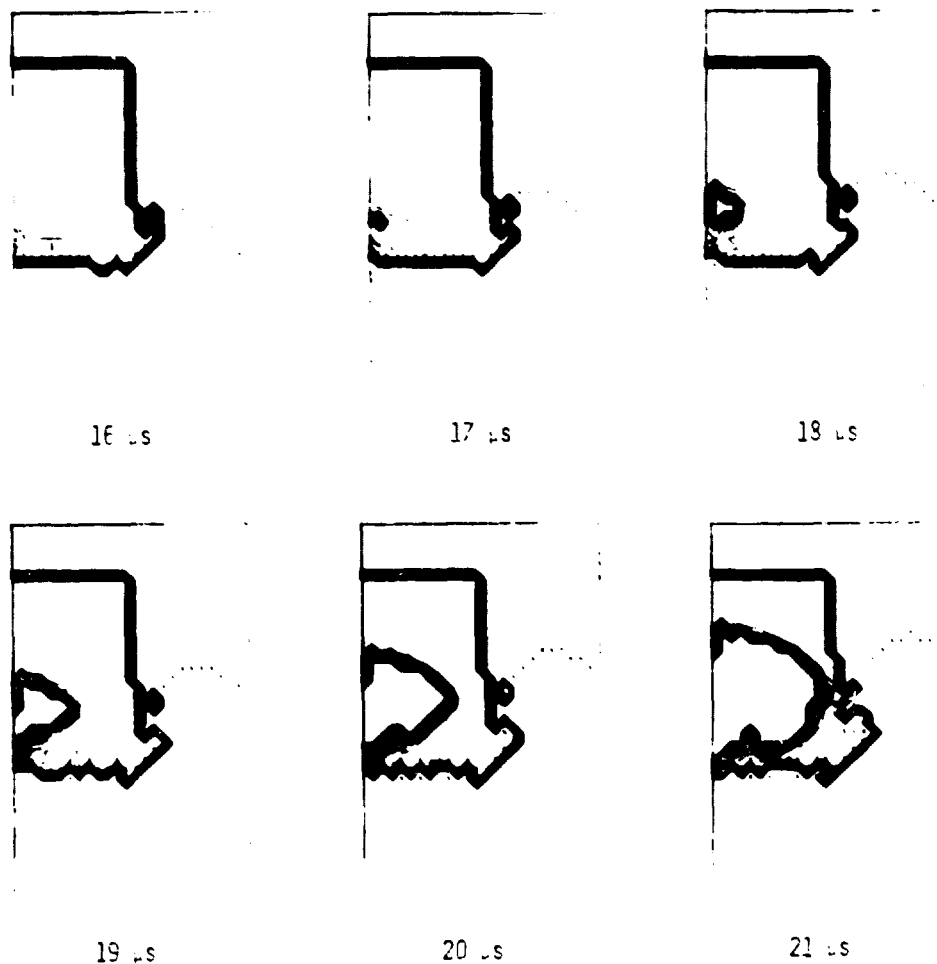

Fig. 10. Detonation in the acceptor cylinder. Mass fraction contour plots, 2-in. cubes of VRO, 3.1 cm gap.

results that the critical separation distance represents the observed transition from high-order detonation to a low-order detonation. Thus, a very significant reaction can be induced by a shock that is too weak to produce a direct shock-initiated detonation. This important phenomenon cannot be described by our present numerical model.

The most complete calculations have been carried out on simulated 2-in. cubes of VRO. These include the basic experiment and numerical studies on the effect of removing the steel backing plate and of impact initiation of the donor cylinder against a steel plate. The calculated critical separation distances for various conditions are compared in Table I. The effect of cube size on the critical separation distance was studied with simulated 1-, 2-, and 3-in. cubes of VRO. The calculated values are compared with experimental results in Fig. 11. It should be noted that extrapolation of the fitted straight line in Fig. 11 to 8-in. cubes gives a predicted critical separation distance of 6.7 in., while a high-order detonation has been observed experimentally at 12 in. Thus one must be careful when extending these results to significantly larger samples. The calculated critical separation distances

TABLE I

CRITICAL SEPARATION DISTANCE

VRO - Cylindrical equivalent of 2-in. cubes

|   | <u>cm</u> | <u>in.</u> |
|---|-----------|------------|
| <b>Cap initiation</b>                         |           |            |
| 1.3-cm steel backing plate                    | 3.64      | 1.43       |
| No support plate                              | 3.42      | 1.35       |
| <b>Impact initiation</b>                      |           |            |
| Flying steel plate (1.3 cm)<br>VO = 0.1 cm/μs | 4.08      | 1.61       |
| Shotgun against steel<br>VO = 0.1 cm/μs       | 2.98      | 1.17       |

for simulated 2-in. cubes of several different propellants are shown in Table II.

The shock pressures that are induced in the acceptor cube are determined by performing the calculation with no decomposition reaction allowed in the acceptor. The shock pressures along the cylindrical axis are shown in Fig. 12 for a simulated 2-in. cube of VRO with a 3.2 cm gap. The maximum induced pressures in VRO are shown in Fig. 13 as a function of separation distance for different cube sizes. The data points are fitted to the curve  $p = Ax^{-n}$ .

The calculated shock pressures and lengths of run to detonation show very good agreement with the Pop plot for VRO. The run distance at the critical separation distance, obtained from the induced pressure curves of Fig. 13 and the Pop plot, is found to be approximately 0.75 times the cylindrical radius of the simulated cube.

The blast pressures that are developed in the air gap are shown in Fig. 14 for the three VRO cube sizes of this study. They are the pressures cal-

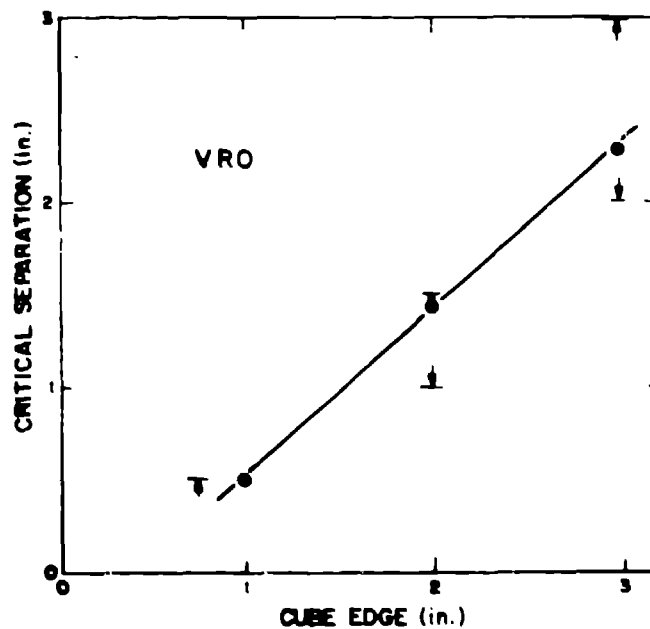

Fig. 11. Variation of critical separation distance with cube size. Calculated values are shown by (●); experimental results are shown by arrows indicating the limits of observation.

**TABLE II**  
**CRITICAL SEPARATION DISTANCE**  
(2-in. cubes)

| <u>Propellant</u> | <u>Calculated*</u><br>(in.) | <u>Experimental</u><br>(in.) |
|-------------------|-----------------------------|------------------------------|
| VOF-7             | 2.8 ± 0.9                   | ---                          |
| VRO               | 1.4 ± 0.1                   | 1 - 1.5                      |
| VRP               | 1.2 ± 0.2                   | 0.5 - 1.0                    |
| VTQ-2             | 2.6 ± 0.2                   | ---                          |

\*The uncertainty in the calculated distance is one-half the distance between calculated go and no-go separation distances.

culated along the cylinder axis of the simulated cubes. These pressures are found to scale with the cube root of the mass. The air shock wave decays quickly to approximately 0.01 GPa, and then decays much more slowly. It is followed by the much stronger detonation products shock wave, which is clearly the cause of the direct shock initiated detonation. The observed shock pressures at the critical separation distance are summarized in Table III. The variation of the peak blast pressure with separation distance is shown in Fig. 15.

The maximum shock pressure in the acceptor is found to be related to the peak blast pressure by the equation

$$p_I = 11.75 p_B^{2/3},$$

where the induced shock pressure  $p_I$  and the blast pressure  $p_B$  are in GPa. This relation is approximately valid for all three cube sizes, within the limits of the data.

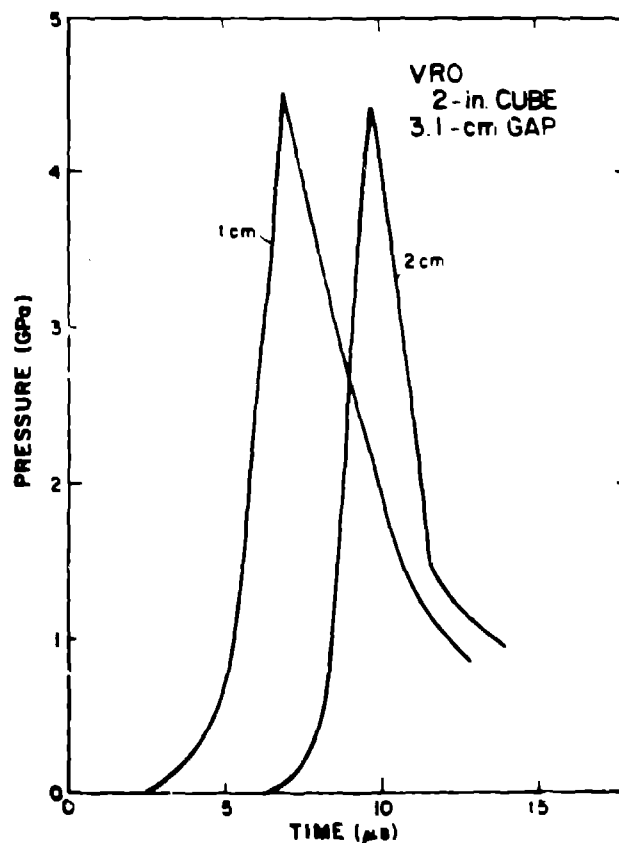

Fig. 12. Shock waves induced in a non-reactive acceptor.



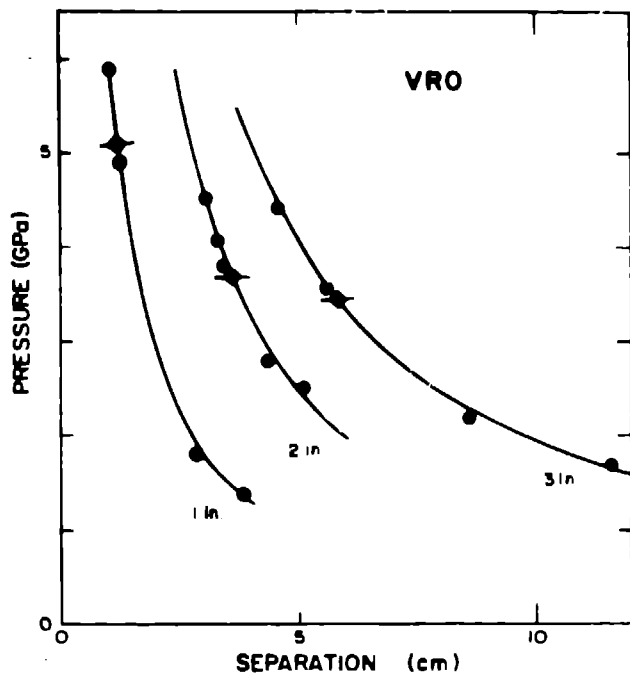

Fig. 13. Variation of the maximum induced pressure in a nonreactive acceptor with separation distance. The critical separation distance is indicated by (◆).

TABLE III

SYMPATHETIC DETONATION OF VRO

|                                   | Cube Size<br>(in.) |      |      |
|-----------------------------------|--------------------|------|------|
|                                   | 1                  | 2    | 3    |
| Critical separation distance (mm) | 12.7               | 36.4 | 57.9 |
| Induced shock pressure (GPa)      | 4.98               | 3.64 | 3.44 |
| Run length (from Pop plot) (mm)   | 10.9               | 23.3 | 26.8 |
| Run length/radius                 | 0.76               | 0.81 | 0.62 |
| Maximum blast pressure (GPa)      | 0.29               | 0.18 | 0.15 |

The induced shock pressure ( $p_I$  in GPa) is related to the separation distance ( $r$  in mm) by

$$p_I = Ar^{-n}$$

|   |      |      |      |
|---|------|------|------|
| A | 100  | 292  | 254  |
| n | 1.18 | 1.22 | 1.06 |

CONCLUSIONS

The wide variety of experimental conditions for the sympathetic detonation tests permit us to draw several conclusions.

Acceptor damage significantly affects sympathetic detonation throw

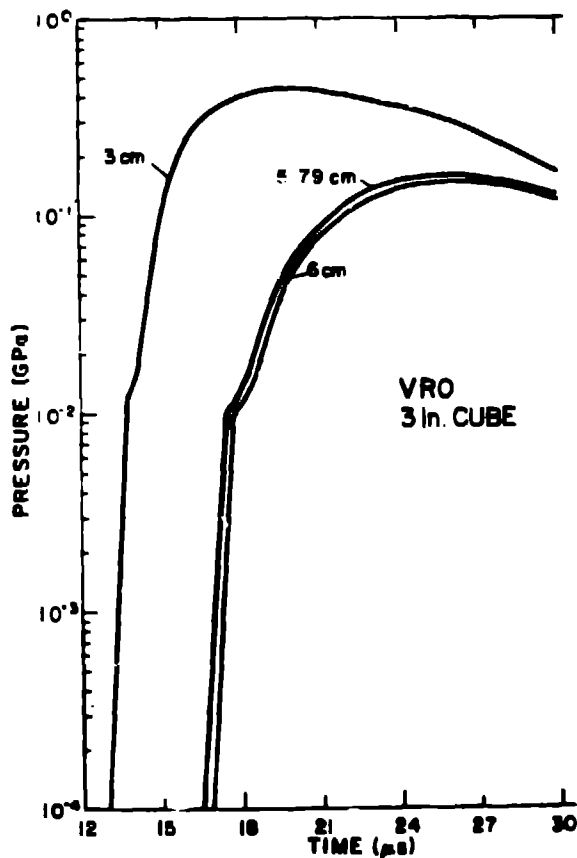
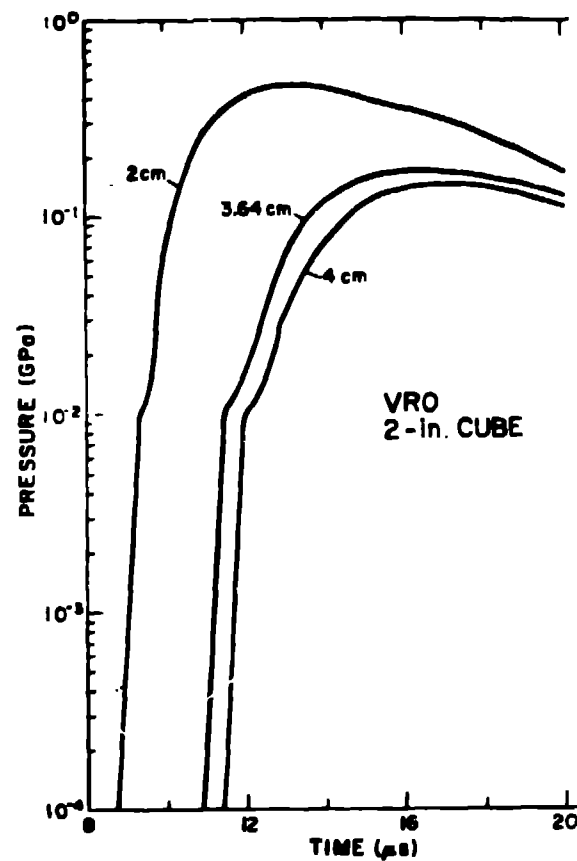
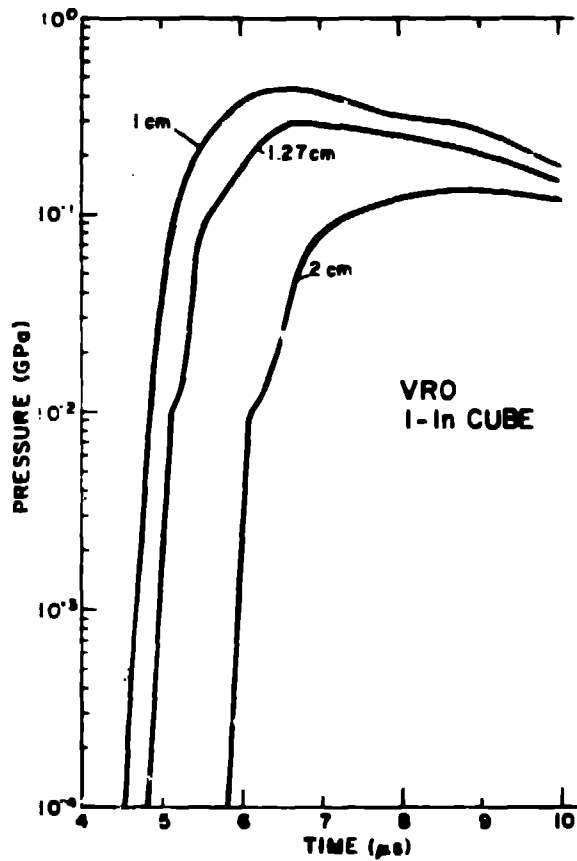

Fig. 14. Blast wave pressures in the air. The middle curve is at the critical separation distance.

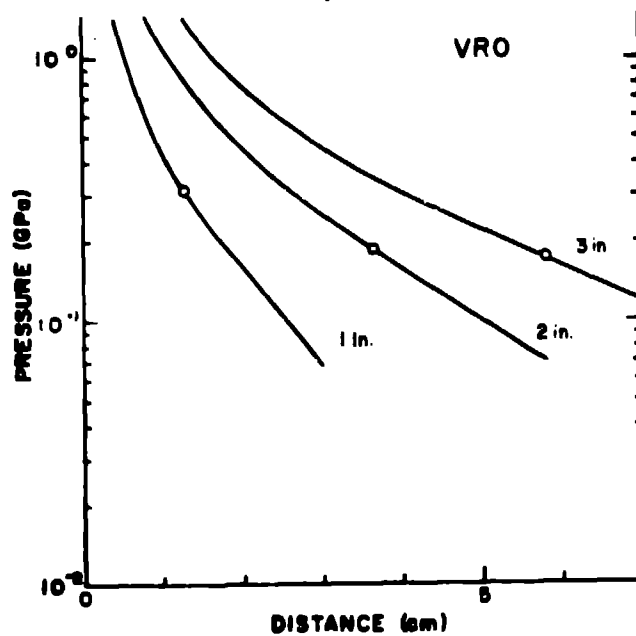

Fig. 15. Variation of peak blast pressure with distance from donor.

distances. All types of acceptor damage investigated thus far (granulated, recovered broken pieces, pressure burst) resulted in increased throw distances. The worst type of acceptor (greatest throw distance) is a granulated acceptor. Sympathetic detonation throw distance seems to increase with increasing surface-to-volume ratio (S/V). For example,  $\frac{1}{4}$ - $\frac{1}{2}$  in. granulation gives greater separation distances (LOD at 3 in.) than  $\frac{1}{2}$ -1 in. granulation (LOD at 2 in.). Reactions increase in intensity along the lengths of granulated acceptors as evidenced by the slanted mushroom tops of the lead witness cylinders after test. For example, the rear portion of the lead witness cylinder's top was lower than the front for tests at 2-, 3-, 4-, 5-, 7-, and 9-in. separation distances. A few broken pieces of propellant mounted on the end of a slug from which the pieces were broken off significantly increase sympathetic detonation throw distances. For example, throw distance increases from 10 in. to greater than 12 in. if the end of a 4.5 in. diameter by 12-in. acceptor is broken. The type of propellant damage resulting from the rupture of a motor can increase sympathetic detonation throw distances. For example, throw distance increases from 5 in. for good propellant (based on interpolation between closest data points) to  $6\frac{1}{2}$  in. for propellant of the same weight recovered from the WSMR-1 (White Sands Missile Range) test. A cylindrical donor can throw a sympathetic detonation farther than a cube to a damaged acceptor. For example, a 4.5 in. diameter cylinder with L/D = 1 caused a damaged acceptor to undergo HOD at 7 in., whereas a cube of the same weight caused only LOD at the same distance. All types of propellant tested (VOY, VRO-2B, VRP) showed an effect of acceptor damage on sympathetic detonation throw distances.

Donors will throw detonations much farther to good and damaged acceptors mounted end-on than to acceptors mounted side-on to the donor. For example, 8 in. diameter by 8 in. cylinders will throw detonations about three times farther to end-on acceptors than to side-on acceptors. The factor by which the end-on throw distance increases above that for the side-on distance increases with sample size (a factor of at least 2 for 2.81 in. by 3 in. cylinders and a factor of about 3 for 8 in. by 8 in. cylinders). Gun-fired (dynamic) donors which detonate upon impact with a steel plate throw detonations farther in the side-on direction than cap-initiated (static) donors. For example, 2.5 in diameter by 3 in. donors fired from a 70 mm gun will throw a detonation 3 in., whereas a cap-initiated donor will only throw to a side-on acceptor  $\frac{1}{2}$  in. away. The critical separation distance for HOD was found to be four times greater if the flat ends of cylindrical samples were mounted face-on to each other rather than the curved sides. The setup for these tests was similar to that shown in Fig. 1 except that 2.81 in. diameter by 3 in. cylinders were used.

There is a significant effect of propellant L/D on throw distances for samples mounted end to end. For example, a 4.5 in. diameter donor with L/D = 3 can throw a sympathetic detonation to a distance  $2\frac{1}{2}$  times farther than a donor of the same diameter with L/D = 1. A 8.3 in. diameter by 24 in. cylindrical donor (L/D = 3) will throw a detonation 5 to 8 in. farther than an 8 in. cube (L/D = 1). Two HOD's were observed with 2 in. diameter by 6 in. donors spaced 2 in. away from similar acceptors, whereas only LOE occurred at the same separation distance with cubes. A cylindrical donor apparently can throw detonations farther than a cube of the same weight. For example,

a 4.5 in. diameter by 4 in. cylinder will throw a detonation about 1 in. farther than a 4 in. cube of the same approximate weight. Sympathetic detonation throw distances apparently increase with increasing sample temperature. For example, a temperature increase of approximately 50°F (34 to 92) threw a detonation 1 in. farther for a 4.5 in. by 4 in. cylinder of VRO. Throw distances may increase if the acceptor is burning. However, this was observed in only one of six tests using 4 in. cube donors that were detonated when the acceptor had burned to an equal weight. VRP may be capable of throwing a detonation farther than VRO-2B. For example, an 8 in. diameter by 8 in. donor of VRP (HOD at 20 in.) equaled an 8 in. diameter by 24 in. donor of VRO (HOD at 20½ in.). The L/D effect noted previously would indicate an expected HOD of 50 in. for the longer VRP sample. Comparison of mixed-size results showed that there is no significant effect of acceptor size (up to and including 8 in. cubes) on throw distances for a given size donor, if the acceptor is at least as large as the donor.

We have successfully modeled the sympathetic detonation of small cylindrical samples of rocket propellants, using the 2DE code with Forest Fire burn rate. The results of the calculations are in very good agreement with experimental observations.

We can predict other results from a consideration of run distances, blast wave pressures, and induced pressures in the acceptor. The necessary condition for detonation of the acceptor cylinder is that the length of run to detonation be less than approximately 0.75 times the radius of the acceptor. This run length is then converted to a necessary minimum induced pressure in the acceptor by means of the Pop plot. The blast pressure required to induce this pressure is obtained by

$$p_B = 0.02483 p_I^{3/2}$$

with the pressures in GPa. The distance from the donor at which this blast pressure will occur can be determined for VRO from the pressure versus distance plot of Fig. 15. These pressure curves may be scaled by cube root of mass for different size donors. The variation of blast pressure for different propellants of interest is very small, and can probably be ignored. The effect of a different method of initiation of the donor cylinder, such as sympathetic detonation or flying plate impact, can be approximated by subtracting the length of run to detonation from the total length to obtain an effective length. This defines a different entry condition for the blast pressure curves.

It should be noted again that this model and the conclusions drawn from it apply only to single-shock initiated detonations in the absence of any effect from fragments.

#### REFERENCES

1. J. D. Kershner and C. L. Mader, "2DE, A Two-Dimensional Continuous Eulerian Hydrodynamic Code for Computing Multicomponent Reactive Hydrodynamic Problems," Los Alamos Scientific Laboratory report LA-4846 (1972).

2. C. L. Mader and C. A. Forest, "Two-Dimensional Homogeneous and Heterogeneous Detonation Wave Propagations," Los Alamos Scientific Laboratory report LA-6259 (1976).
3. C. L. Mader, "FORTRAN BKW: A Code for Computing the Detonation Properties of Explosives," Los Alamos Scientific Laboratory report LA-3704 (1967).
4. C. L. Mader, Numerical Modeling of Detonations (University of California Press, Berkeley, 1979).