

# **LEGIBILITY NOTICE**

A major purpose of the Technical Information Center is to provide the broadest dissemination possible of information contained in DOE's Research and Development Reports to business, industry, the academic community, and federal, state and local governments.

Although a small portion of this report is not reproducible, it is being made available to expedite the availability of information on the research discussed herein.

DEC 04 1989

Los Alamos National Laboratory is operated by the University of California for the United States Department of Energy under contract W-7405-ENG-36

LA-UR--89-3702

DE90 003168

TITLE SIZE DETERMINATIONS OF PLUTONIUM COLLOIDS USING AUTOCORRELATION PHOTON SPECTROSCOPY

AUTHOR(S) I. R. Triay, R. S. Rundberg, A. J. Mitchell, M. A. Ott, D. E. Hobart, P. D. Palmer, T. W. Newton, and J. L. Thompson

SUBMITTED TO Proceedings for Migration '89, Monterey, CA, November 6-10, 1989

DISCLAIMER

This report was prepared as an account of work sponsored by an agency of the United States Government. Neither the United States Government nor any agency thereof, nor any of their employees, makes any warranty, express or implied, or assumes any legal liability or responsibility for the accuracy, completeness, or usefulness of any information, apparatus, product, or process disclosed, or represents that its use would not infringe privately owned rights. Reference herein to any specific commercial product, process, or service by trade name, trademark, manufacturer, or otherwise does not necessarily constitute or imply its endorsement, recommendation, or favoring by the United States Government or any agency thereof. The views and opinions of authors expressed herein do not necessarily state or reflect those of the United States Government or any agency thereof

By acceptance of this article the publisher recognizes that the U.S. Government retains a non-exclusive, royalty-free license to publish or reproduce the published form of this contribution, or to allow others to do so, for U.S. Government purposes.

The Los Alamos National Laboratory requests that the publisher identify this article as work performed under the auspices of the U.S. Department of Energy.

Los Alamos Los Alamos National Laboratory Los Alamos, New Mexico 87545

# SIZE DETERMINATIONS OF PLUTONIUM COLLOIDS USING AUTOCORRELATION PHOTON SPECTROSCOPY

I. R. Triay, R. S. Rundberg, A. J. Mitchell, M. A. Ott,  
D. E. Hobart, P. D. Palmer, T. W. Newton, and J. L. Thompson  
Los Alamos National Laboratory, Los Alamos, NM 87545

Autocorrelation Photon Spectroscopy (APS) is a light-scattering technique utilized to determine the size distribution of colloidal suspensions. The capabilities of the APS methodology have been assessed by analyzing colloids of known sizes. Plutonium(IV) colloid samples were prepared by a variety of methods including: dilution; peptization; and alpha-induced auto-oxidation of Pu(III). The size of these Pu colloids was analyzed using APS. The sizes determined for the Pu colloids studied varied from 1 to 370 nanometers.

**KEYWORDS:** Plutonium, Colloid, Size, Autocorrelation, Light Scattering, Spectroscopy

## INTRODUCTION

Colloid migration is a potential mechanism for the release of actinides from an underground repository of high-level radioactive waste. McDowell-Boyer<sup>1</sup> et. al. have discussed the mechanisms for collisions between the colloids and the media as well as the conditions for attachment within the context of filtration models. Predictions using filtration theory<sup>1</sup> indicate that particles smaller than a micrometer migrating through porous media will be captured because the frequency of particle-media collisions due to Brownian motion increases as the particle size decreases.

The objective of this investigation is to determine the sizes of Plutonium(IV) colloids prepared by dilution, peptization, and alpha-induced auto-oxidation of Pu(III) using Autocorrelation Photon Spectroscopy (APS). The results obtained will be utilized to analyze the ability of tuffs at Yucca Mountain (the proposed site for the nation's high-level nuclear waste repository) to act as natural filters for Pu colloids.

## Autocorrelation Photon Spectroscopy Instrumentation

Autocorrelation Photon Spectroscopy is a highly sensitive, non-destructive technique capable of determining the sizes of particles in the submicron range. The spectrometer available at the Isotope and Nuclear Chemistry Division of Los Alamos National Laboratory consists of a Brookhaven Instruments Corporation system (BI-200 particle sizer and BI-2030 correlator) with a Coherent Argon Ion laser. The principles of operation of the

APS system have been described.<sup>2</sup> Laser light is directed onto a vial containing a colloidal suspension. The light scattered by the particles in the suspension is detected. As the suspended particles undergo Brownian motion in the liquid, the distance the scattered light travels to the detector varies as a function of time. Depending on the differences in the distances traveled to the detector, scattered light can interfere constructively or destructively. The result is an average intensity with superimposed fluctuations. The frequencies of the fluctuations depend on the sizes of the suspended particles. The fluctuating signal produced is analyzed by autocorrelation.

The schematic representation of the APS system is given in Fig. 1. The details of the APS instrumentation have been given.<sup>2</sup> The Argon Ion laser (tuned to the 514.5 nm line) is focused by lens L1 onto a temperature-controlled sample cell. The scattering angle  $\theta$  shown in this diagram is 90°; consequently, the pinholes P1 and P2 define the light scattered at 90° to the incident laser light. This scattered light is focused by lens L2 onto a photomultiplier. Uniform electrical pulses are produced from the amplified signal using an amplifier with a discriminator (AMP/DISC). The fluctuating (time-varying) signal is autocorrelated. An IBM PC/AT compatible microcomputer is used to form the autocorrelation function, perform data analysis, and print results (if desired).

### Governing Equations

The mathematical description of the autocorrelation function is well understood.<sup>2,3</sup> Suspended particles undergoing Brownian motion produce a signal that fluctuates from the average intensity of the scattered light. The autocorrelation function  $g(t)$  is created as a function of time by processing the fluctuating signal. Equation 1 describes the behavior of the autocorrelation function for a suspension of single-size particles: for short times correlation is high; as  $t$  increases, correlation is lost, and  $g(t)$  approaches a constant baseline,  $B$ ; in between these limits,  $g(t)$  decays exponentially.

$$(g(t) - B)^{1/2} = Ae^{(-\Gamma t)} \quad (1)$$

For a suspension of multiple-size particles, each size contributes its own exponential. Consequently, the generalized autocorrelation function consists of a sum of single exponentials, as given in eq. 2.

$$(g(t) - B)^{1/2} = A \int_0^{\infty} G(\Gamma)e^{-\Gamma t} d\Gamma \quad (2)$$

In the autocorrelation function,  $A$  is an optical constant and  $G(\Gamma)d\Gamma$  is the fraction of the total intensity scattered by particles obeying eq. 3, where  $D$  is the diffusion coefficient, and  $k$  is the scattering vector given by eq. 4.

$$\Gamma = Dk^2 \quad (3)$$

$$k = \frac{4\pi n}{\lambda} \sin(\theta/2) \quad (4)$$

In eq. 4,  $n$  is the index of refraction of the suspending liquid,  $\lambda$  is the wavelength of the laser light, and  $\theta$  is the scattering angle. For spherical particles the diameter of the particle is related to the diffusion coefficient by the Stokes-Einstein relation, given in eq. 5, where  $k_B$  is the Boltzmann constant,  $T$  is the absolute temperature,  $\eta$  is the viscosity of the suspending liquid, and  $d$  is the diameter of the particle.

$$D = k_B T / 3\pi\eta d \quad (5)$$

## DATA ANALYSIS

The data-analysis methods utilized to determine particle size distributions using APS have been reviewed.<sup>3</sup> The software options available with the BI-2030 correlator implement the method of cumulants, the technique of exponential sampling, and a non-linear least squares analysis for particle size determinations. In addition, a code has been written implementing the technique of constrained regularization for data analysis.

In the method of cumulants<sup>3</sup> the autocorrelation function is expanded about an average  $\Gamma$ . The resulting autocorrelation function fitted is a polynomial with cumulants (equivalent to moments about  $\Gamma$  average) as parameters. The exponential sampling technique<sup>4</sup> utilizes the inversion of the Laplace transform, based on the eigenfunctions and eigenvalues of the transform, to obtain  $G(\Gamma)$ . The non-linear least squares method<sup>3</sup> requires that the solution  $G(\Gamma)$  minimize the sum of squared residuals based on the autocorrelation data  $g(t)$  and their respective predictions using the calculated  $G(\Gamma)$  in equation 2.

The method of constrained regularization implemented in the code written was presented by Butler, Reeds, and Dawson.<sup>5</sup> This method employs a nonnegativity constraint to find a solution  $G(\Gamma)$  that can minimize the sum of two quantities. One quantity is the sum of squared residuals based on the data  $g(t)$  and their respective predictions using the calculated  $G(\Gamma)$  in equation 2. The other quantity is a quadratic functional of  $G(\Gamma)$  which provides smoothing in the solution obtained.

## RESULTS AND DISCUSSION

The performance of the APS system for size determinations has been tested using National Institute of Standards and Technology (NIST) polystyrene spheres suspended in water. The standard reference materials utilized were spheres 1690 (895 nm) and 1691 (269 nm). In all the analyses made the scattering angle  $\theta$  was  $90.0^\circ$ , the temperature was  $25.0^\circ\text{C}$ , the viscosity was 0.8900 cP, and the index of refraction was 1.332.

Figure 2 shows the autocorrelation data as a function of time collected for NIST standard 1691. The size distribution recovered from these data utilizing constrained regularization is shown in Figure 3, where the size distribution  $G(\Gamma)$  has been normalized by dividing all the distribution values by the largest distribution value found in the diameter range studied (from 0.01 to 10000 nm).

All the data-analysis methods utilized were able to successfully determine the sizes of the NIST standards measured. Table 1 shows the average as well as the most probable diameters obtained for standards 1691 and 1690. Reporting the most probable diameter obtained using the method of cumulants is not appropriate since this technique fits the autocorrelation data to an average  $\Gamma$ . The exponential sampling, nonlinear least squares, and the constrained regularization techniques yield the distribution  $G(\Gamma)$ . As previously discussed the  $\Gamma$  values are related to the particle diameters by invoking equations 3-5.

The size of Pu(IV) colloids has been analyzed using APS. Table 2 shows the most probable diameters of Pu colloids prepared by dilution, peptization, and alpha oxidation of Pu(III). The results obtained using constrained regularization are reported because this technique was capable of resolving the two sizes in a mixture of Pu colloids whereas the exponential sampling and the non-linear least squares techniques could not resolve the two sizes in the mixture (as shown in Table 3). Figures 4 and 5 show the autocorrelation data and the size distribution, respectively, for the mixture of Pu colloids. The relative area under the first peak in the distribution shown in Figure 5 is  $3.7 \times 10^{-3}$ ; the relative area under the second peak is 0.996. It is important to understand that these areas correspond to a scattered intensity distribution  $G(\Gamma)$ . In order to convert intensity distributions to number, weight, or volume distributions Mie Scattering theory has to be invoked<sup>6</sup>.

The smallest Pu colloid measured (1.54 nm in diameter) was prepared using the method of Savage and Kyffin.<sup>7</sup> Dilution of a well characterized Pu(IV) stock solution using distilled water yields colloids in the range of 2-6 nm in diameter. Peptization yielded a mixture of Pu colloids with two different sizes. Alpha oxidation of Pu(III) yielded the largest single-size Pu colloid measured.

Several Pu colloids were placed in contact with groundwater obtained from the J-13 well of the Nevada Test Site. This water is representative of the groundwater available at Yucca

Mountain (the potential site for a nuclear waste repository). The APS analysis of the Pu colloids in J-13 water was unsuccessful. The reason for the failure of the analysis could be the formation of very large pseudocolloids outside the range of the APS system. Future work will involve the analysis of Pu colloids in synthetic groundwaters (with the same chemical composition as J-13 water but without the particulate impurities). Centrifugation and filtration will be used to obtain Pu colloids in J-13 water in a size range appropriate for APS analysis.

## CONCLUSIONS

Polystyrene spheres of known sizes were used to test the performance of the APS system. Several data-analysis methods were utilized for particle size determinations. All methods studied were capable of predicting the size of the polystyrene standard colloids accurately.

The size of Plutonium (IV) colloids prepared by dilution, peptization, and alpha-induced oxidation of Pu(III) was measured using APS. The method of constrained regularization successfully determined the two sizes in a mixture consisting of two Pu colloids (1.5 and 33.4 nm in diameter); none of the other data-analysis methods were capable of resolving the two sizes.

The Pu(IV) colloids prepared in distilled water ranged in size from 1-370 nm. According to filtration theory<sup>1</sup> colloids smaller than one micrometer migrating through porous media will be filtered by the media. The Pu colloids placed in groundwater could not be analyzed using APS. The formation of very large pseudocolloids in groundwater could be responsible for the failure of the APS data analysis.

*Acknowledgement.* This research has been supported by the Nevada Nuclear Waste Storage Investigations Project, U.S. DOE.

## REFERENCES

1. McDowell-Boyer, L. M., Hunt, J. R., Sitar, N.: *Water Resources Research* **22**, 1901 (1986).
2. *Instruction Manual for Model BI-2030AT Digital Correlator*, Brookhaven Instruments Corporation, New York 1986.
3. Stock, R. S., Ray, W. H.: *Journal of Polymer Science* **23**, 1393 (1985).
4. Ostrowsky, N., Sornette D., Parker P., Pike E. R.: *Optica Acta* **28**, 1059 (1981).
5. Butler, J. P., Reeds, J. A., Dawson, S. V.: *SIAM J. Numer. Anal.* **18**, 381 (1981).
6. Bott, S. E.: Submicrometer Particle Sizing by Photon Correlation Spectroscopy: Use of Multi-Angle Detection. In *Particle Size Distribution* (T. Provder, ed.) American Chemical Society, Washington, DC 1987, p.74.
7. Savage, D. J., Kyffin T. W.: *Polyhedron* **5**, 743 (1986).



Table 1: Results Obtained using NIST Standards

Average Diameter, nm					
NIST Standard	Actual	Method of Cumulants	Exponential Sampling	Non-linear Least Squares	Constrained Regularization
1691	269.0	269.2	269.0	261.0	273.6
1690	895.0	892.2	893.0	872.0	937.3

Most Probable Diameter, nm					
NIST Standard	Actual	Method of Cumulants	Exponential Sampling	Non-linear Least Squares	Constrained Regularization
1691	269.0	-	269.0	278.0	262.0
1690	895.0	-	893.0	808.0	856.0

Table 2: Size Determination of Pu Colloids

Pu(IV) Colloid	Form of Preparation	Most Probable Diameter(s), nm Analyzed using Regularization
1	Diluting Pu(IV) stock using distilled water and aging at room temperature	2.62
2	Adding Pu(IV) stock dropwise to distilled water	3.70
3	Adding Pu(IV) stock dropwise to distilled water and heating to 75-80°C	5.68
4	Taking Pu(IV) stock to dryness and adding distilled water to resuspend	2.98
5	Taking Pu(IV) stock to near dryness and adding distilled water at 70°C to resuspend	2.08
6	Neutralizing most of the free acid in a Pu(IV) solution using sodium hydroxide	1.54
7	Peptization - precipitating Pu(IV) with ammonia, resuspending using distilled water, and heating to 80°C	13.60, 370.00
8	Alpha Oxidation of Pu(III)	31.60
9	Mixing colloids 5 and 8	1.54, 33.40

Table 3: Mixture of Pu Colloids

Colloid	Most Probable Diameter, nm		
	Exponential Sampling	Non-Linear Least Squares	Constrained Regularization
5	3.0, 6.0	3.0	2.1
8	30.0, 59.0	36.0	31.6
9	30.0, 43.0	27.0	1.5, 33.4

Figure 1: Block Diagram of APS System (from Reference 2)

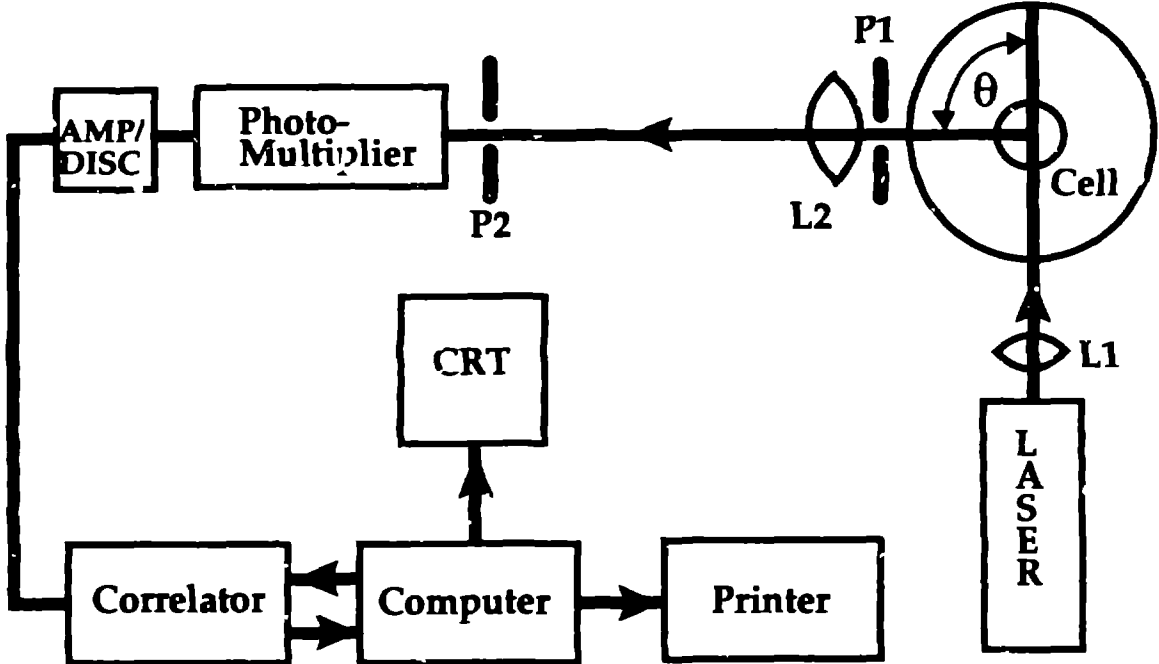

Figure 2: Autocorrelation Data for NIST Standard 1691

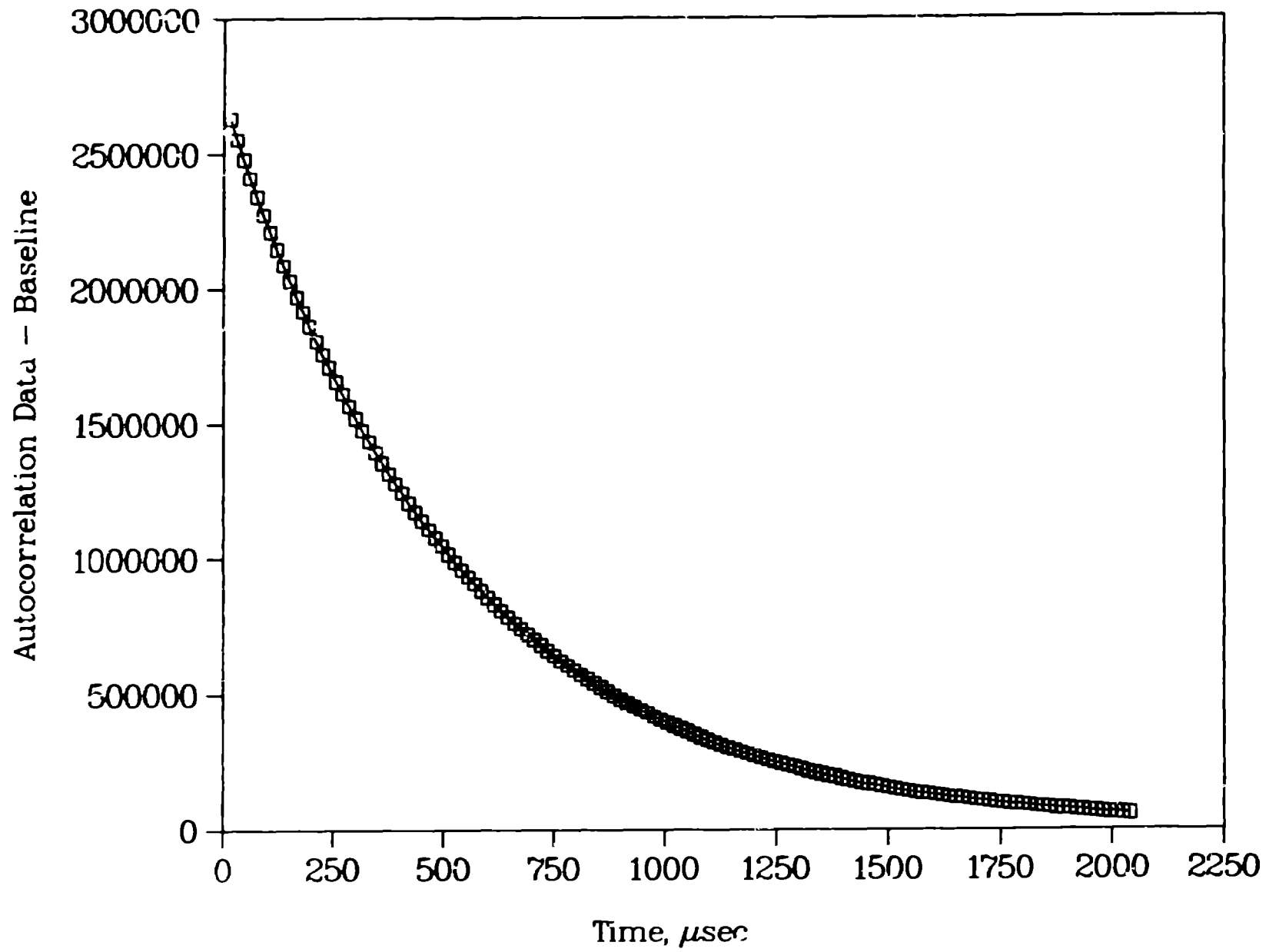

Figure 3: Size Distribution of NIST Standard 1691  
Results Analyzed using Regularization

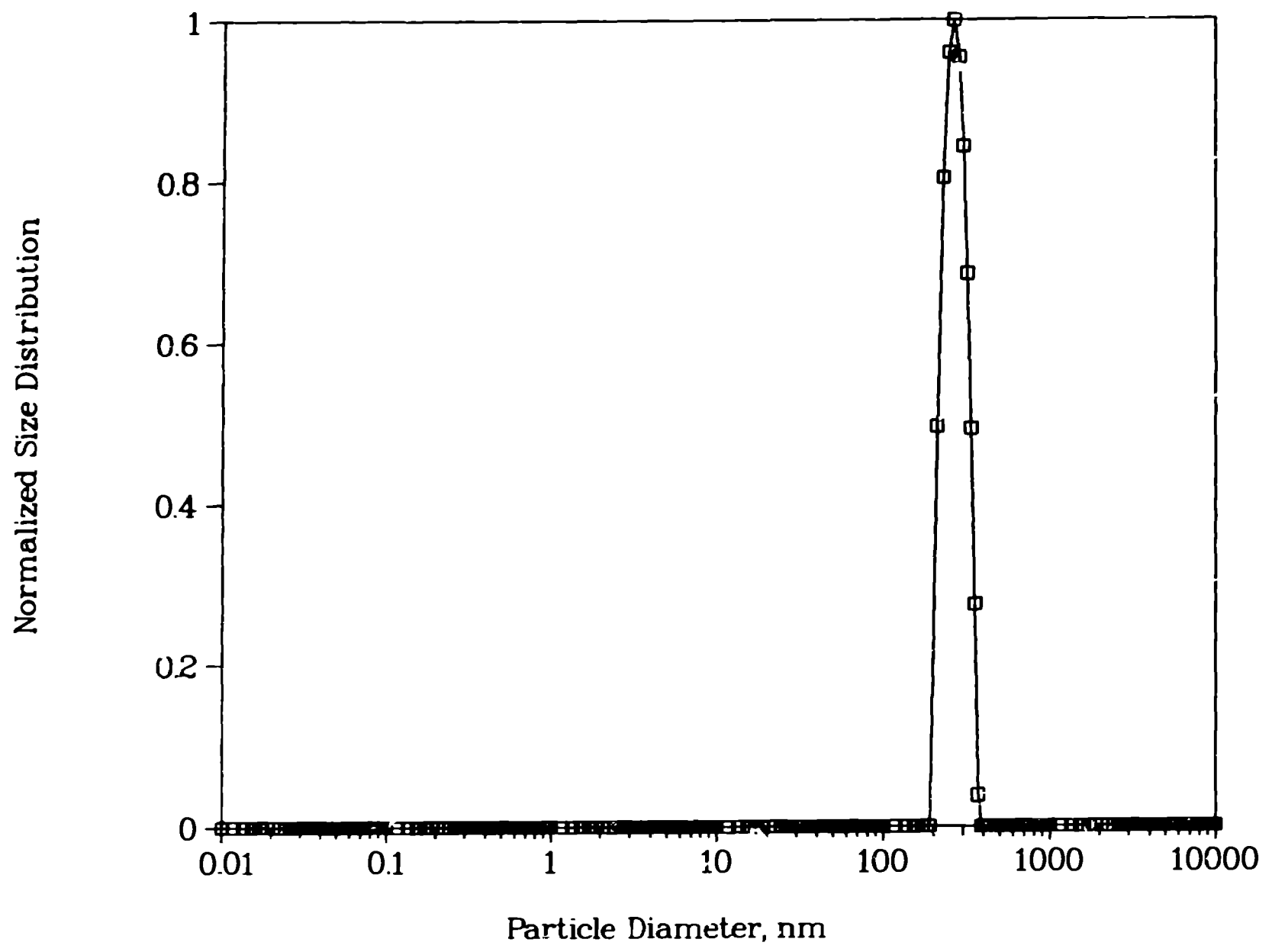

Figure 4: Autocorrelation Data for Mixture of Pu Colloids

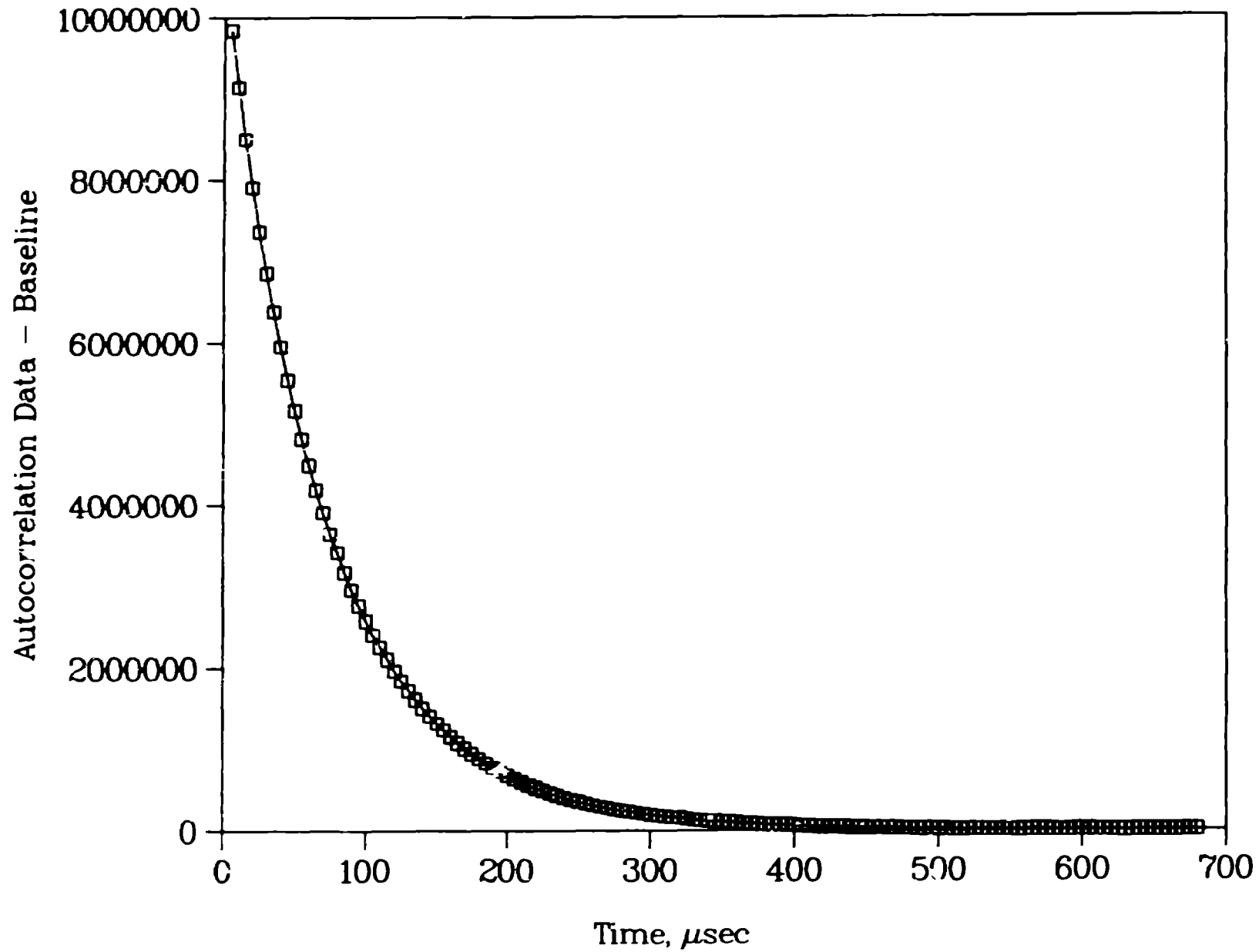

Figure 5: Size Distribution of Mixture of Pu Colloids  
Results Analyzed Using Regularization

