

Wash. DC  
11/14 - 11/19/76

CONF-761101--1

# HIGH-PRESSURE TRITIUM EQUIPMENT

DON O. COFFIN *Los Alamos Scientific Laboratory*  
*University of California P.O. Box 1663, Mail Stop 980*  
*Los Alamos, New Mexico 87545*

KEYWORDS: tritium

## MASTER

### ABSTRACT

*Some solutions to problems of compressing and containing tritium gas to 200 MPa at 700 K are discussed. The principal emphasis is on commercial compressors and high-pressure equipment that can be modified easily by the researcher for safe use with tritium. Experience with metal bellows and diaphragm compressors has been favorable. Selection of materials, fittings, and gauges for high-pressure tritium work also is reviewed briefly.*

### INTRODUCTION

Fusion-energy research is rapidly increasing the need for better tritium technology. Laser-induced fusion will require extending this technology to higher pressures and temperatures. Though several problems persist in the compression and containment of tritium under these conditions, a large backlog of experience already is available. Los Alamos Scientific Laboratory (LASL) has a great deal of experience handling tritium gas at pressures as high as 175 MPa (25,000 psi)<sup>a</sup> and at temperatures to 700 K. At these conditions, it is possible to permeate hollow laser-fusion targets with deuterium-tritium (DT) gas in relatively short times.

The purpose of this presentation is to review some of the problems of handling tritium gas at high pressures and temperatures and the approaches we have taken toward their solution.

<sup>a</sup>One megaPascal (MPa) is equal to 145.0 lb/in.<sup>2</sup>.

Most of the remaining problems could be solved by today's technology if tritium users could clearly communicate their needs to the manufacturers.

### GENERAL CONSIDERATIONS

The problems of containment of tritium at high pressures are essentially the same as for hydrogen. All structural members must be relatively impermeable to hydrogen and absolutely free from hydrogen embrittlement. These requirements are made more stringent by the fact that tritium is radioactive, toxic, and expensive. Austenitic stainless steel generally provides adequate strength at both cryogenic and ambient temperatures. Where higher strength or lower bulk is required, composite vessels can be built with austenitic stainless steel as the liner. For high-temperature autoclaves, stainless steels are unsatisfactory because of the high hydrogen permeabilities of iron and nickel. We have used beryllium copper to 675 K with some success. Other approaches are to use a composite vessel with a low permeability liner (copper or aluminum) and a high-strength shell, or a cold-wall vessel with the insulated, heated reactor immersed in pressurized gas.<sup>1</sup>

Any tritium system built today must meet extremely low emission standards; secondary containment is the only reliable means of staying below such release levels. For a high-pressure system, this can present serious design problems. The secondary container must enable recovery of the tritium released by a failure, and must withstand damage from high-velocity fragments ejected at the same time. It is desirable to design high-pressure components for a negligible probability of catastrophic failure and to rely on the containment system to control only leakage.

Another problem introduced by tritium involves

**DISCLAIMER**

**Portions of this document may be illegible in electronic image products. Images are produced from the best available original document.**

## DISCLAIMER

This report was prepared as an account of work sponsored by an agency of the United States Government. Neither the United States Government nor any agency thereof, nor any of their employees, makes any warranty, express or implied, or assumes any legal liability or responsibility for the accuracy, completeness, or usefulness of any information, apparatus, product, or process disclosed, or represents that its use would not infringe privately owned rights. Reference herein to any specific commercial product, process, or service by trade name, trademark, manufacturer, or otherwise does not necessarily constitute or imply its endorsement, recommendation, or favoring by the United States Government or any agency thereof. The views and opinions of authors expressed herein do not necessarily state or reflect those of the United States Government or any agency thereof.

the choice of seal materials—compression gaskets, valve packings and seats, etc. The average tritium beta particle (6 keV) has several orders of magnitude more energy than any organic bond. Tritium also is active chemically and exchanges readily with normal hydrogen, accelerating the decomposition of organic materials. Slow deterioration of plastics and elastomers can be tolerated perhaps in a vacuum or atmospheric pressure system, but pure tritium at 200 MPa generates radiation at a density approaching 2000 Ci/cm<sup>3</sup>; the useful life of all elastomers and most plastics can be measured in hours. It is often overlooked that the decomposition products of some organic materials are also highly corrosive. The fluorocarbons, which decompose into tritium fluoride, are a particularly vicious example. We once traced an epidemic of metal-bellows failures in a low-pressure system to this cause.

The solution is to use metal gaskets wherever possible and to design any necessary plastic seals so that a minimum surface is exposed to the tritium. Where the resiliency or low friction of a plastic is still required, as in high-pressure valve packings or soft-seat check valves, we have found the polyimides<sup>2</sup> to be the most radiation resistant. They also have satisfactory physical properties for high-pressure seals.

#### VALVES AND FITTINGS

Most commercial high-pressure fittings are intrinsically suitable for use with tritium, but users are advised to set up their own certification and acceptance standards to supplement the quality-control procedures of the manufacturer. This is only prudent when all the costs of an accidental release of tritium are considered. The fluorocarbon stem packings in commercial high-pressure valves can be successfully replaced with polyimide plastic. This not only improves the radiation resistance, but also reduces packing extrusion and cold flow. At LASL, we use a rotary pneumatic actuator<sup>3</sup> as a remote valve operator (Fig. 1). We prefer this device to the diaphragm-type operator available from most manufacturers because the rotary design limits both stem travel and closing torque. Thus, valve seats and packings seldom require replacement, and infrequent maintenance is the most important factor in reducing personnel exposures.

#### Gauges

Gauging is a particularly demanding problem because tritium is a controlled radioactive material, and its accountability at high pressure is best done by accurate pressure-volume-tempera-

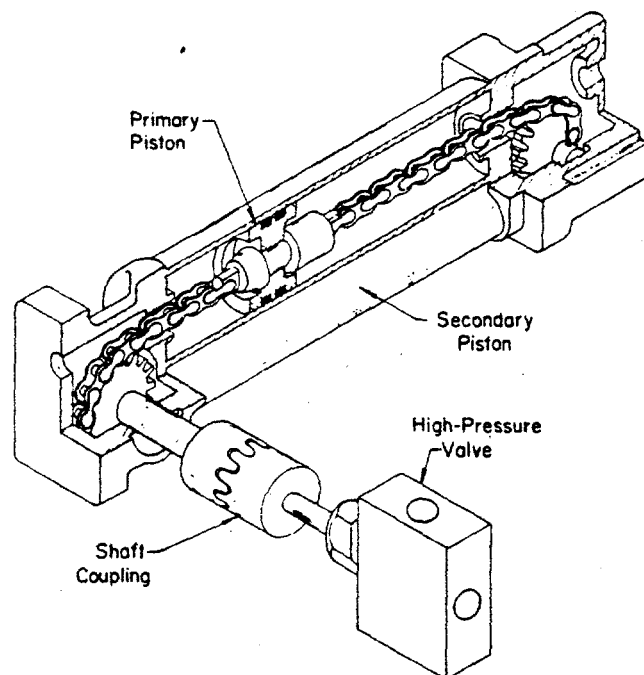

Fig. 1. Remote high-pressure valve operator.

ture measurements. Gauges that operate by deflection of an elastic member necessarily incorporate smaller safety factors than desired for conservative design. Nevertheless, Bourdon-tube gauges have served the pressure industry for more than a century, and are a good choice for tritium if the Bourdon material is hydrogen-compatible. Many manufacturers furnish Bourdon gauges in austenitic stainless steels or beryllium copper in a wide range of pressures. The addition of force-balancing and digital-readout techniques has greatly enhanced the precision of these inherently simple devices. Strain-gauge transducers are preferred by many experimenters now. Solid-state digital electronics and improved quality control have resulted in precisions rivaling those of the force-balance Bourdon-tube systems. All-welded transducers of tritium-compatible materials are also available from several manufacturers.

#### COMPRESSORS

The principal constraints on tritium pumps, enumerated by Folkers and Gede,<sup>4</sup> are that they incorporate no moving shaft seals, elastomers, or organic fluids. Compressors that readily can meet these requirements generally fall into one of three classes: (a) mercury-column compressors, (b) thermal-cycle and change-of-phase pumps, and (c) flexible metal-membrane compressors.

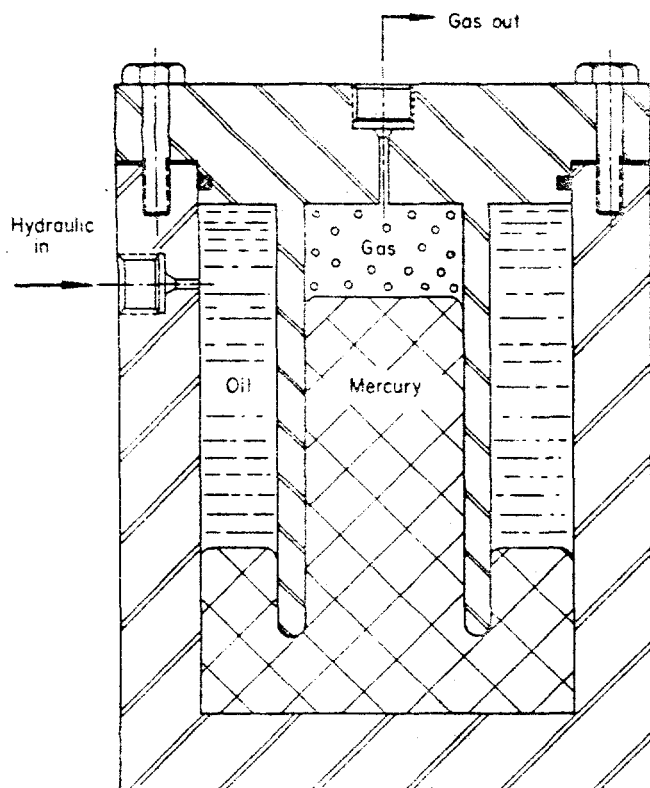

Fig. 2. Mercury-column compressor.

Mercury is compatible with hydrogen and was used in many early tritium compressor designs<sup>5</sup> because of the ease with which shaft seals could be protected by liquid metal. Although mercury is not attacked by tritium, it is incompatible with other common pressure-system materials, and effective trapping of vapor and droplets carried by a dense, high-velocity gas is difficult. If the pressure system contains no amalgamable metals, and if some level of mercury vapor can be tolerated in the compressed tritium, a commercial mercury-column compressor<sup>6</sup> may provide a ready solution (Fig. 2).

Classification (b) includes plain and adsorbent-assisted cryopumps, hot-gas thermal compressors, and metal-hydride pumps.<sup>7</sup> Devices of this type are simple in design and contain no moving parts. Only static seals are required for closing the working volume and introducing any electrical leads; many satisfactory solutions have been developed for these. The main limitations on these designs are: limited capacity in a reasonable physical size and slow cycle speed. Small volumes can be pumped to quite high pressures with one of these devices of modest dimensions if the experimenter can wait an hour or so between cycles. These pumps are not available from com-

mercial sources as complete systems, but often can be assembled from commercial high-pressure components.

Classification (c) comprises compressors that employ metal bellows or diaphragms. Several manufacturers make diaphragm compressors.<sup>6,8,9</sup> The best models for tritium incorporate a stainless-steel diaphragm welded to the gas head. Since reliable welds are difficult to make for service above 100 MPa, we are using a hydraulically loaded seal of gold plating on the gas diaphragm. At 140 MPa, no tritium leakage can be detected with the usual portable air monitor, and diaphragm life is almost infinite if the gas is free of particulates. The utilization of triple diaphragms<sup>8</sup> (Fig. 3) with an appropriate vent port can give effective secondary containment for the most likely mode of compressor failure. At LASL, we have used a multistage diaphragm pump routinely to compress tritium to 140 MPa. The only continuing maintenance has been frequent changes of interstage check valves, which originally had fluorocarbon face seals and elastomer poppets. These materials have now been replaced with polyimides. Some of these valves are still operating well after two years of intermittent tritium service.

Metal-bellows compressors<sup>16</sup> have come on the market in the past few years. A design limitation of the standard compressor for tritium is excessive use of fluorocarbon plastic in the check-valve header. We have replaced this with an all-metal valve assembly. The manufacturer will provide an all-welded assembly at considerable extra cost. Because the mechanically driven bellows is unsupported, the output pressure is limited to ~0.5 MPa. The only interest in this pump for the high-pressure experimenter, therefore, is as a transfer pump or as the first stage of a multistage system.

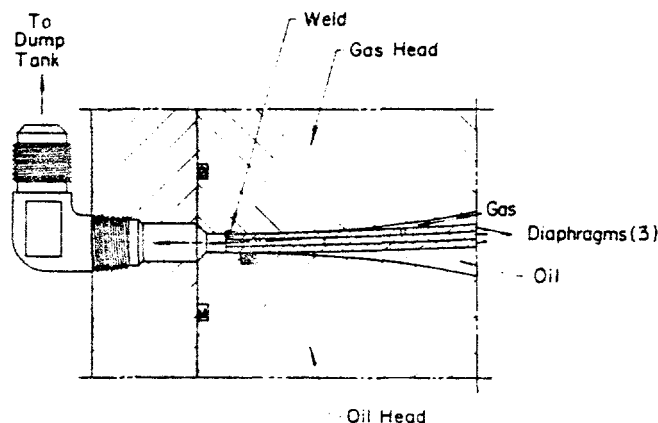

Fig. 3. Triple-diaphragm construction.

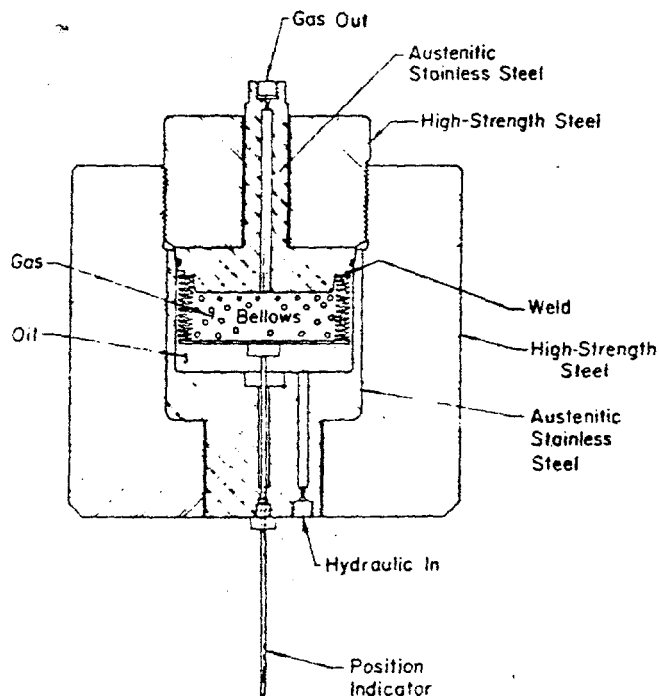

Fig. 4. High-pressure bellows compressor.

At LASL, a balanced-pressure hydraulically driven metal-bellows compressor has been built (Fig. 4). It is designed to give a 50/1 compression ratio at 200-MPa discharge. Coupled to a suitable output volume, it can provide very sensitive pressure control by using a hydraulic proportioning pump. Driven by a conventional hydraulic plunger pump, it is capable of one 250-cm<sup>3</sup> stroke/min.

#### CONCLUSION

Although several manufacturers make compressors and hardware that can be modified for

tritium use, no current item of off-the-shelf equipment is completely satisfactory. For example, every diaphragm-pump supplier uses some fluorocarbon or elastomer in the compressor even though these could be avoided. Tritium users in the fusion-energy program must fully inform industry on the requirements for tritium handling. Now that tritium is emerging as a vital fuel for the world's future energy needs, we can and must apply the best current technology to its safe handling and containment.

#### REFERENCES

1. J. F. LAKNER, "Proposed Pressure Vessel Concept, etc.," UCID-16833, Lawrence Livermore Laboratory (1975).
2. E. I. du Pont de Nemours & Company, Inc., Plastics Department, Wilmington, Delaware 19898.
3. Fluid Components Division, Deltrol Corporation, Grant and 30th Avenue, Bellwood, Illinois 60104.
4. C. L. FOLKERS and V. P. GEDE, *Proc. 23rd Conf. Remote Syst. Technol.*, 55 (1975).
5. F. J. EDESKUTY, *Ind. Eng. Chem.*, 51, 69 (1959).
6. American Instrument Company, Silver Spring, Maryland 20910.
7. D. H. CARSTENS, *Proc. 23rd Conf. Remote Syst. Technol.*, 69 (1975).
8. Pressure Products Industries, 900 Louis Drive, Warminster, Pennsylvania 18974.
9. Autoclave Engineers, 2930 West 22nd Street, Erie, Pennsylvania 16512.
10. Metal Bellows Company, 1075 Providence Highway, Sharon, Massachusetts 02067.