

time-of-arrival location technique

Gamma-ray bursts occur unpredictably in time and in location, Instruments with an inherent capability to locate these bursts precisely are extremely complex and, indeed, not yet fully developed. However, the locations of burst sources can be determined with relatively simple instrumentation from the arrival times of the burst wavefront at each of several widely separated satellites. The absolute difference Δt in the arrival time of the signal at any two satellites is directly related to the absolute difference in the path length d over which the signal travels ($d = c\Delta t$). With only two satellites the many locations that satisfy this relationship define a hyperboloid of revolution about the line between the two satellites. As shown in Fig. 1a, this hyperboloid of revolution may be approximated by a cone if the distance to the source is large compared to the distance between the satellites. If observations from a third satellite are available, the allowed locations are reduced to two directions in space defined by the intersections of two such cones (Fig. 1b). One of these is the true location of the source and the other is its mirror image in the plane defined by the three satellites. Addition of a fourth satellite, not located in the same plane, allows discrimination against this mirror image.

In practice the cones are presented as their circular projections on the celestial sphere. Also, in accounting for the uncertainties in defining these circles, they must be presented

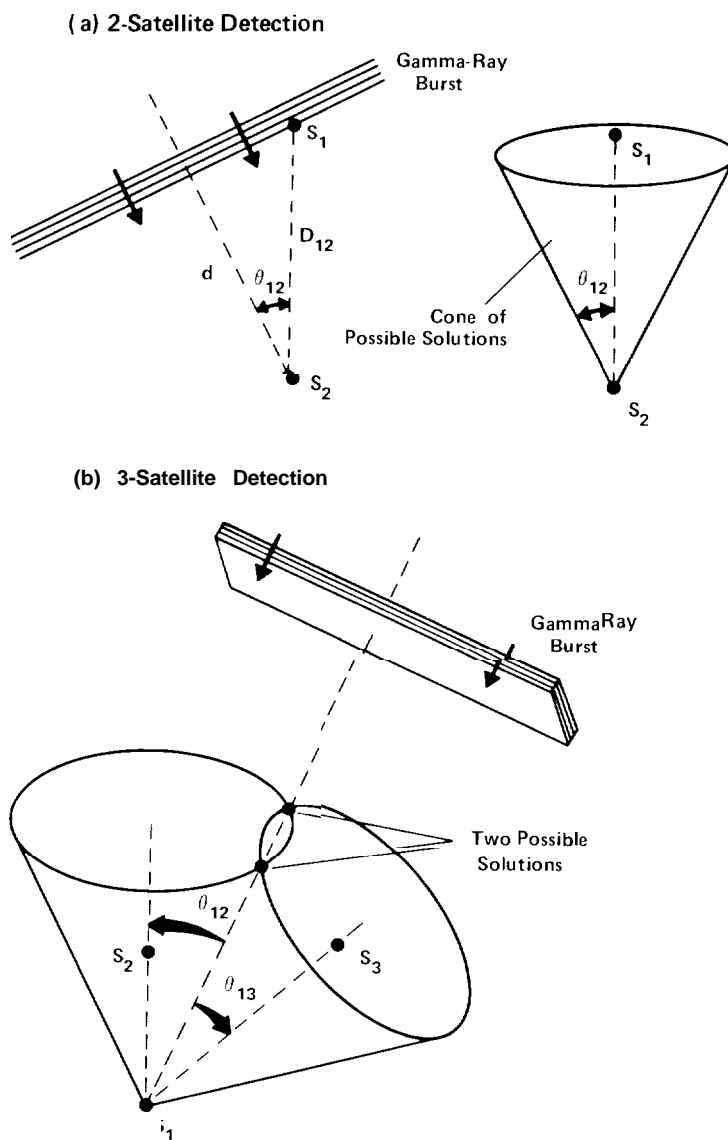

Fig. 1. Time-of-arrival location technique. (a) When a cosmic gamma-ray burst is detected by two satellites (S_1 and S_2), the angle θ_{12} between the line connecting the satellites and the direction of motion of the burst wavefront can be calculated using the known separation D_{12} between the satellites and the distance d determined from the difference in arrival times of the burst at the satellites. This angle gives a cone of possible directions to the gamma-ray burst source. (b) With three satellites, two solution cones are generated, and the intersections of these cones give two possible directions.

Sidebar 1

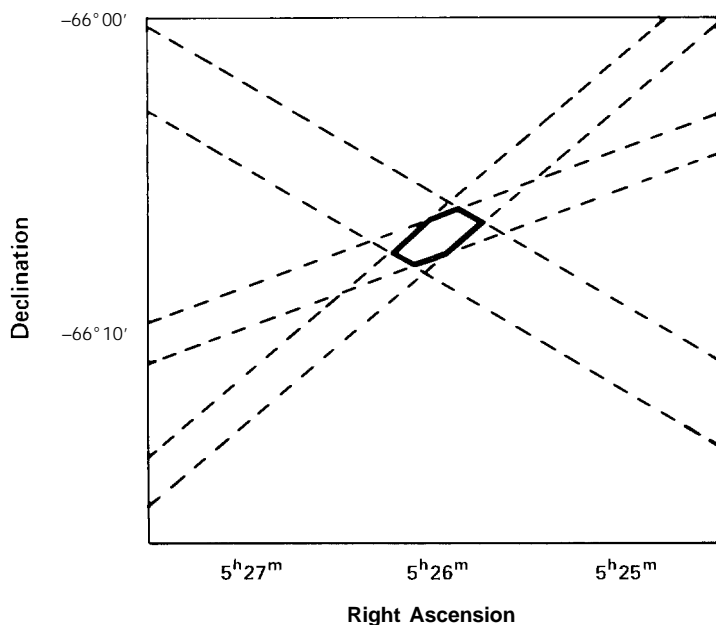

Fig. 2. *The location box. The dashed bands here are the projections of the cones and their associated uncertainties onto the celestial sphere for the initial determination of the March 5, 1979 burst. The polygon resulting from the intersections of the bands contains the location of the source.*

as annular bands, the widths of which are proportional to the estimated uncertainty. The intersections of these bands define an "error box" that contains the location of the source (Fig. 2).

In the present detection network, satellites that are close to each other (for example, the group in orbit about the earth) do not generally improve the accuracy of the location. However, if a variety of detection systems are present in such a cluster, the data can be crosschecked, systematic errors can often be identified, and the arrival time at this cluster determined with a high degree of confidence. For an observation performed by a single satellite, or two identical satellites, it is difficult to verify that there are no systematic errors remaining in the data.

Thus, various factors, including the intensity of the event, the presence of bold temporal features that can serve as identifiable time markers from detector to detector, the spatial distribution of the members of the array at the time of the event, and the availability of shared data, affect the accuracy with which the location of the source can be resolved. The intensity, rapid rise time, and redundancy of observation of the March 5, 1979 burst gave the members of the international consortium an opportunity to verify the accuracy of the location technique. While a number of systematic errors were disclosed and corrected in the analysis of this event, a discrepancy that exceeds the anticipated errors still remains in the analysis of some other events. ■

nature of the spectrum. The Vela 5 detectors responded to photons with energies between 150 and 750 kiloelectron-volts (keV), whereas the Vela 6 detectors responded to somewhat higher energies between 300 and 1500 keV. A comparison of the response of both systems to the same events provided the first crude indication of the energy spectrum. Soon, however, measurements by true spectrometers became available. For example, instruments aboard two International Monitoring Platform satellites (IMP 6 and 7) measured the spectral distribution of many events more definitively. Over the energy range of the measurements, the observations could be fit by a simple exponential function with a characteristic index of 150 keV; that is, the number of photons at energy E is proportional to $\exp(-E/150)$.

A few bursts, however, have been observed by x-ray detectors with responses down to lower photon energies. One of these measurements (performed from Apollo 16) demonstrated that the spectral distribution for that event was consistent with the shape expected for thermal bremsstrahlung from an optically thin plasma at temperatures of several billion kelvins (thermal bremsstrahlung is discussed below in the section "Radiation Mechanism."). This result is not at odds with the exponential shape defined by the IMP observations, but represents further definition of the spectral shape by extension of the measurement to lower photon energies. Two other gamma-ray bursts were observed by the x-ray detectors aboard the Vela spacecraft, and one of these was also observed by an x-ray detector aboard the Orbiting Solar Observatory satellite, OSO-7. These measurements were also consistent with a thermal bremsstrahlung distribution.

By 1978 the Soviet KONUS experiment began routinely to observe gamma-ray bursts over a wide energy range: 30 to 1000 keV. These observations also indicated a spectral shape consistent with optically thin thermal bremsstrahlung. In addition KONUS