

ADC-559

~~UNCLASSIFIED~~
~~[REDACTED]~~

CIC-14 REPORT COLLECTION
**REPRODUCTION
COPY**

Classification Cancelled or Changed
TO

By Authority of *Geo. S. Chaplin*
Los Alamos Lab. Rm

Name	Title	Date
<i>G. R. Russell</i>	<i>Secy</i>	<i>5/27/79</i>

PUBLICLY RELEASABLE
LANL Classification Group
Robert [unclear] 1/18/90

LAMS-669
Series A

C. 3

~~[REDACTED]~~

12 January 1948

This document contains 25 pages.

ELECTRONICS OF THE VAN DE GRAAFF

Work done by:

- G. G. Everhart
- H. T. Gittings
- A. H. Hemmendinger
- J. L. McKibben

Report written by:

H. T. Gittings

LOS ALAMOS NATIONAL LABORATORY
3 9338 00405 6130

UNCLASSIFIED

meeting of the [unclear] [unclear] [unclear]
 U.S. [unclear] the national defense of the
 Act, 50 U.S.C. 31 and 32 as amended
 mission [unclear] [unclear] [unclear] in any
 [unclear] [unclear] [unclear]
 [unclear] [unclear] [unclear]

UNCLASSIFIED

- 2 -

Abstract

During the past year there have been several changes in the electronic circuits used with the Van de Graaff accelerator (short tank). The purpose of this report is to gather together all the circuits now in use.

LOS ALAMOS NATL LAB LIBS
3 9338 00405 6130

UNCLASSIFIED

UNCLASSIFIED

- 3 -

Electronics of the Van de GraaffP3-200 Regulator for Leland 400 cycle 110 V, 2 K.V.A. alternator

The motor generator set has a d.c. exciter for the main alternator field. The control field is excited by about 20 ma derived from a rectifier tube and controlled by a power triode. The generator output voltage is rectified and balanced against a dry battery. The unbalance is amplified in a direct coupled amplifier and drives the output triode and hence the control field in the direction to compensate for the original fluctuation.

In the rectifying process a frequency sensitive element (0.5 μ fd condenser) is included which compensates for the frequency dependence of the main load, which is a high voltage transformer, driving a rectifier circuit.

P3-201 High voltage supply for electrostatic analyzer

This is the load referred to above. It consists of a voltage doubler circuit, a resistor stack and current limiting devices to the analyzer plates. The two resistor stacks are made up of precision resistors, four, 5 megohm, wire wound and one 700 ohm in series in each stack. The voltage across the two 700 ohm resistors is taken to a L. and N. potentiometer and spot-light galvanometer. This accurate measurement of analyzer voltage gives an accurate measure of the main tank voltage. The calibrated relationship from the $L(p,n)$ threshold is: tank voltage in megavolts is equal to potentiometer setting times 2.03.

UNCLASSIFIED

UNCLASSIFIED

- 4 -

P3-202 Analyzer regulator

An auxiliary regulator for the above circuit is a balanced phototube on the spotlight galvanometer. The phototube drives a direct coupled amplifier which drives a saturable reactor in the primary of the high voltage transformer. This circuit obviates any manual corrections during the day after the first setting has been made; and in addition allows one to change the potentiometer setting slowly and have the analyzer voltage follow.

P3-203 Energy control

This circuit looks at the beam of diatomic ions which comes through the electrostatic analyzer. If the ion energy is the correct value the beam will be picked up equally on two collection plates on the end of the analyzer tube. The two plates are separated vertically so that an increase in tank voltage and hence in ion energy will cause the beam to be deflected less by the analyzer and hit more on the bottom plate and vice-versa. The two plates go to grids of a balanced cathode follower, and through 100 meg grid resistors to a point about 300 volts below ground. This insures the loss of all secondary electrons and so amplifies the signal. Any unbalance in the two cathodes followers is amplified (direct-coupled) and used to drive a gammatron transmitting tube whose plate is connected to corona points in the tank opposite the high voltage shell. Controlling the corone current changes the charge on the high voltage shell and hence the voltage and the beam energy, in the right direction of course to correct the original fluctuation.

While this circuit will compensate small changes, it is not very

UNCLASSIFIED

- 5 -

effective in correcting for the larger, slower variations, such as line voltage, spray current, etc., since the gammatron has a limited range of corona current control.

F3-204 Spray current regulator

This circuit looks at the gammatron grid signal, integrates the variations and applies any slow changes from the correct grid bias to a saturable reactor circuit (F3-205).

The saturable reactor controls the voltage to the kenotron supply for the belt spray current and so the spray current is continuously adjusted to keep the average gammatron grid bias at a fixed level.

F3-206 Magnetic analyzer control

The ion beam is magnetically analyzed so as to give pure ion beams for experimental use. The geometry of the system requires that the magnetic field be readily variable but remain constant at any setting to an accuracy of about one part in ten thousand. As the magnet has a large air gap it is reasonable only to worry about keeping the direct current through the magnet windings constant.

This is accomplished by comparing the voltage developed by the magnet current across a manganin shunt to a reference voltage derived from a large dry battery. Any unbalance in these two voltages is amplified by a zero phase-shift, high gain, direct-coupled amplifier and applied to the grids of a bank of power triodes in series with the magnet in such a way as to compensate the original fluctuation. The compensation is not perfect due to the nature of the circuit but can be made less than one part in ten thousand by using sufficient gain in the amplifier. The power for the magnet circuit is obtained from a three-phase, full-wave,

selenium oxide rectifier, delivering 170 volts d.c. at up to three amperes.

P3-207 Balance indicator

Two collection plates in the target tube are used as a rough means of setting the magnet current. A balanced cathode follower drives a panel meter to show whether the magnet current is too high or too low.

P3-208 Electrostatic shim

A pair of deflection plates in the target tube is used as a fine control to position the beam vertically. Only a fine control is necessary since the target tube remains reasonably horizontal. The applied d.c. voltage is adjustable from minus 300 v. to plus 300 volts.

P3-209 Current integrator

The important measurement of the machine is the number of ions which get into the target. This measurement is made in two ways. A battery operated, sub-miniature tube, cathode follower drives a panel meter to read ion beam current directly, in microamperes. A current integrator is used to measure the total number of ions during a run. The beam current charges up a condenser, across which is a cathode follower. The cathode follower drives another cathode follower with a Western Electric, sealed mercury relay in the cathode circuit. At a definite condenser voltage the relay is pulled in and its contacts discharge the condenser, restarting the cycle and giving a pulse which triggers a thyratron and operates a mechanical register at the rate of one count per microcoulomb.

To take into consideration the fact that inductance of the relay coil causes it to vary its operating point for different rates of increase of coil current, a resistor is added in series with the condenser.

- 7 -

The voltage across the resistor is proportional to the beam current. The back voltage of the relay is proportional to the rate of increase of relay coil current which is proportional to the rate of charging of the condenser, which is also proportional to the beam current. Thus for any one relay, a certain value of resistance will completely compensate the inductive effect.

The integrator calibration is flat to one-half percent from 0.005 μ .a. to 20 μ .a. which well covers the present range of the machine. The circuit is arranged so the grid of the first tube stays at almost constant potential to ground and the power supply rides up and down. This compensates for any small leakage paths, and Faraday cage capacitance. Included on the integrator chassis is a minus 300 volt d. c. power supply which operates an electron barrier to keep secondary electrons from escaping and giving inaccurate current measurements.

F3-210. Generating voltmeter

The generating voltmeter is useful as an indicator of tank voltage when the voltage is off the limits of the energy control circuit. The output of the generating voltmeter is approximately a sixty cycle triangular wave, the amplitude being dependent on the external impedance loading it.

A cathode follower with a 50 megohm grid resistor gives about 10 volts at 2 megavolts tank voltage. This is rectified with a Sylvania crystal I K 34 and drives a panel meter with a linear scale of 3 megavolts.

F3-211 Protection circuit

With rare gases used in the target a protection circuit is necessary in case of a punctured foil where the beam enters the target.

- 8 -

Protection is achieved by using an ion gauge in front of the target and an over-pressure relay (P3-212). The relay operates a bell and solenoid controlled valve in the target tube to catch the escaping gas. As a secondary protection, a spark plug driven by a neon transformer sticks into the tube in front of the target. If the gas pressure rises due to a leak the spark plug breaks down and the resultant current operates a relay which operates the solenoid and bell. Another relay prevents any belt spray current unless the protection circuit is turned on.

In addition to the above circuits directly connected with the operation of the machine there are several built in circuits to be briefly listed.

- a) 8 -- scale of 64, scalars and discriminators.
- b) 1 -- triple coincidence circuit.
- c) 1 -- double coincidence circuit.
- d) 1 -- 10 channel discriminator.

The only one of these not adequately covered elsewhere is the double coincidence circuit (P3-213). This circuit, suggested by Dexter, employs a 6 A S 6 pentode with one input to the control grid and one input to the suppressor grid. Resolving time is less than a microsecond.

P3-214 Circuits in high voltage head

Power is supplied to these circuits by a belt driven generator with outputs of 200 volts d.c. and 130 volts a.c. The d.c. is used for the ion source arc and the a.c. supplies power via variacs for the probe voltage, ion source filament, and palladium heaters.

P3-215 Knudsen gauge telemeter

The Knudsen gauge reading^a is a light spot on a translucent, calibrated scale. For remote reading a bank of ten, end-on phototubes is mounted in place of the scale. Each phototube drives a cathode-follower. The output of the cathode-follower drives a 1/25 watt neon lamp on or off, according to the position of the light spot. There is enough over-lap so that if the light spot is midway between two phototubes both neon lamps are on. This gives nineteen lamp-on combinations, or about five percent accuracy of reading.

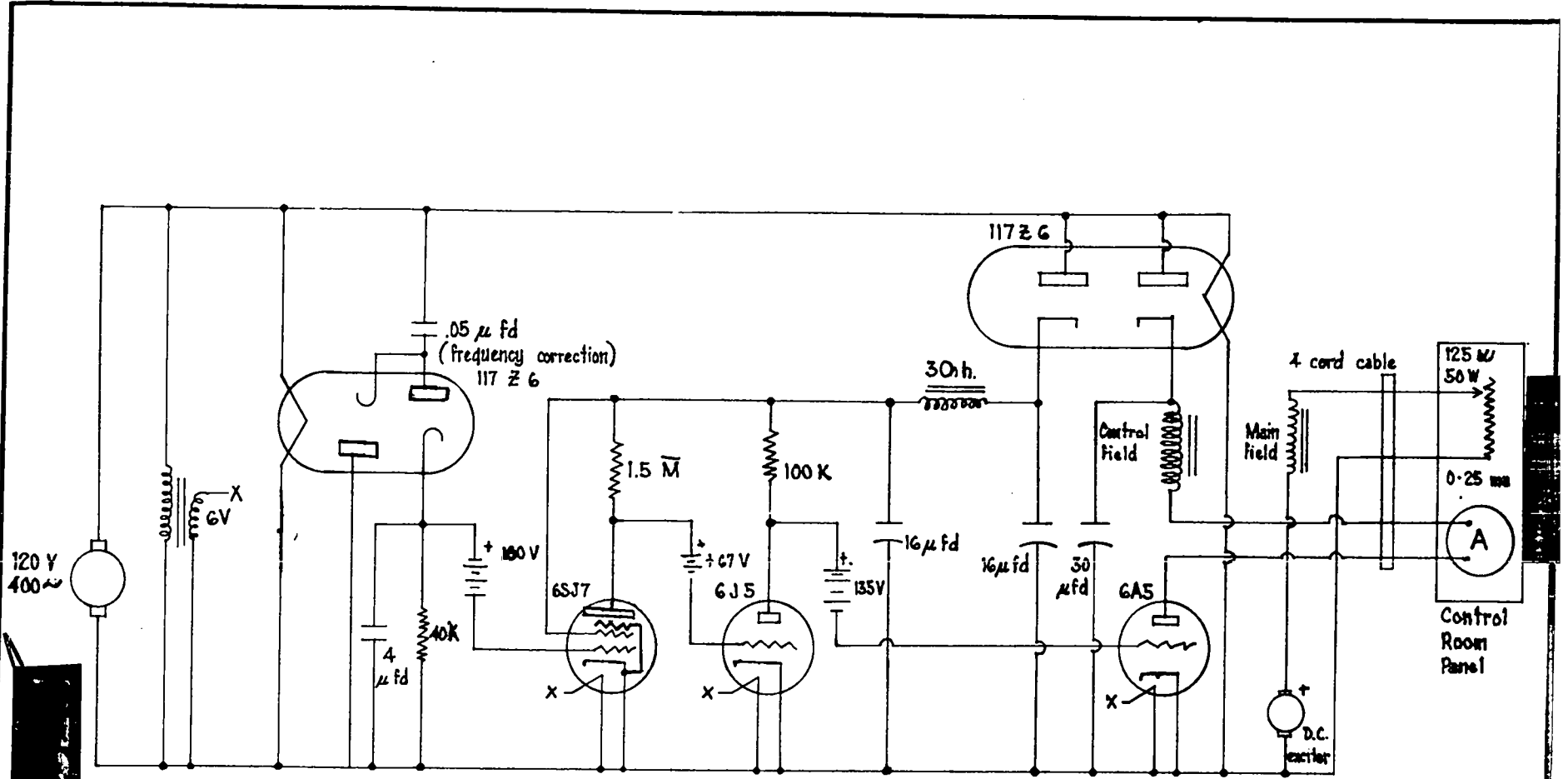

ω = ohm
 K = ohm $\times 10^3$
 M = ohm $\times 10^6$
 W = watts
 V = volts

APPROVED FOR CONST.		REV. LET.		CHANGED ITEM WAS	BY	DATE
CHIEF ENG. <i>McAllister</i>						
CH. DRFTSM. <i>L.M.P.</i>	DEC. 15 '47					
CHECKED	BITTNER	DEC. 11, 1947	TITLE Regulator for 120 V 2KVA 400 CRS Generator			
DRAWN	R.P.H.	DEC. 9, 1947				
LAYOUT OR SKETCH			SCALE	DRAWING NO.	SHEET SIZE AND NO.	
GROUP P-3	REPRESENTATIVE BITTNER		= 1"	P3-200	B	
FRACTIONAL TOLERANCE $\pm 1/100$ UNLESS OTHERWISE NOTED.					TOTAL 1	

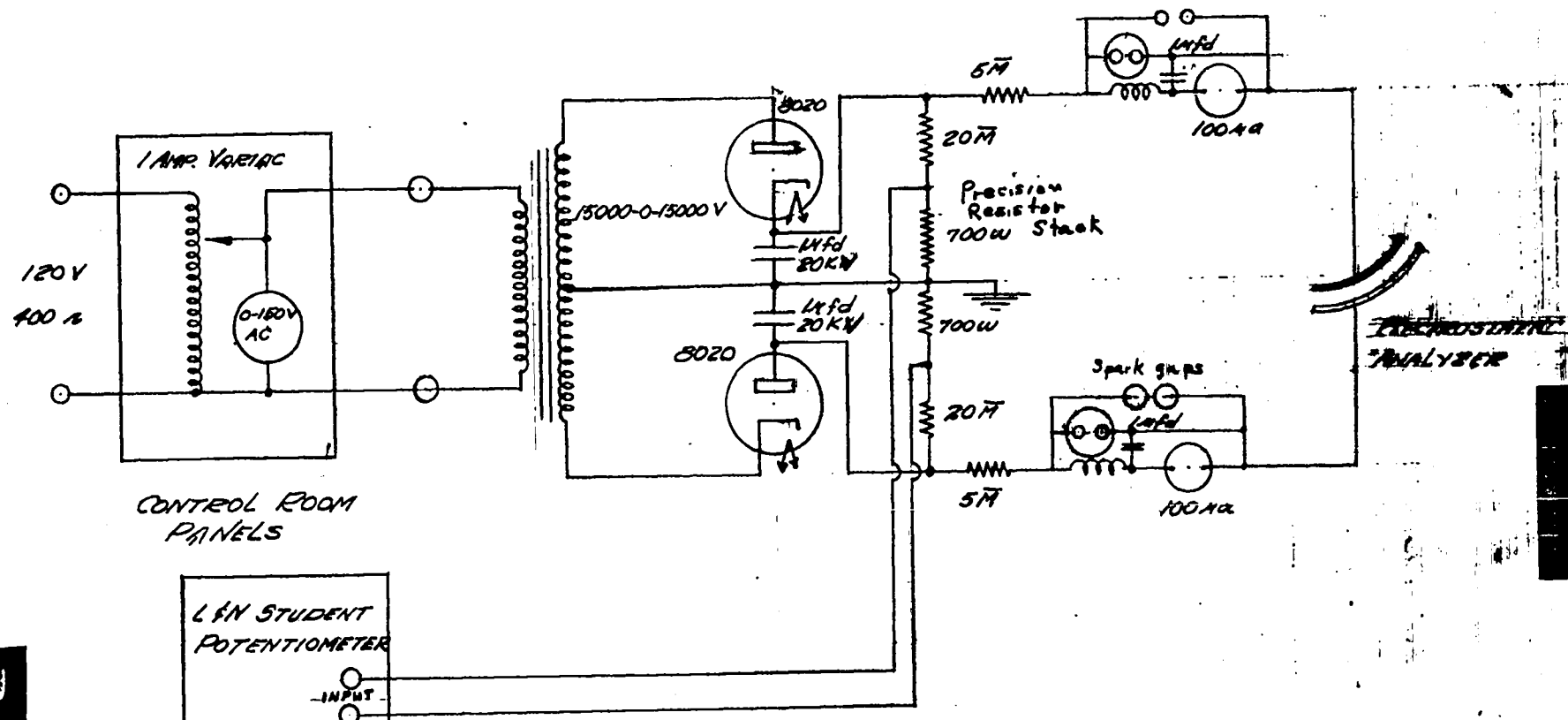

CONTROL ROOM PANELS

LEN STUDENT POTENTIOMETER
INPUT

W = ohm
K = ohm $\times 10^3$
M = ohm $\times 10^6$
KV = VOLTS $\times 10^3$
⊙ — SPARK GAP

APPROVED FOR REISSUE		CHANGED ITEM NOS	BY	DATE
DESIGNED BY	L.H.C. D.K.V.	TITLE		
CHECKED BY	W.F. GAG	POWER SUPPLY FOR ELECTROSTATIC ANALYZER		
DRAWN BY	W.F. GAG	SCALE	SHEET NO. AND NO.	
LAYOUT BY		NONE	8-4-201	
DATE	9-5	ORIGIN	TOTAL	
FRACTIONAL TOLERANCE $\pm 1\%$ UNLESS OTHERWISE SPEC.			1	

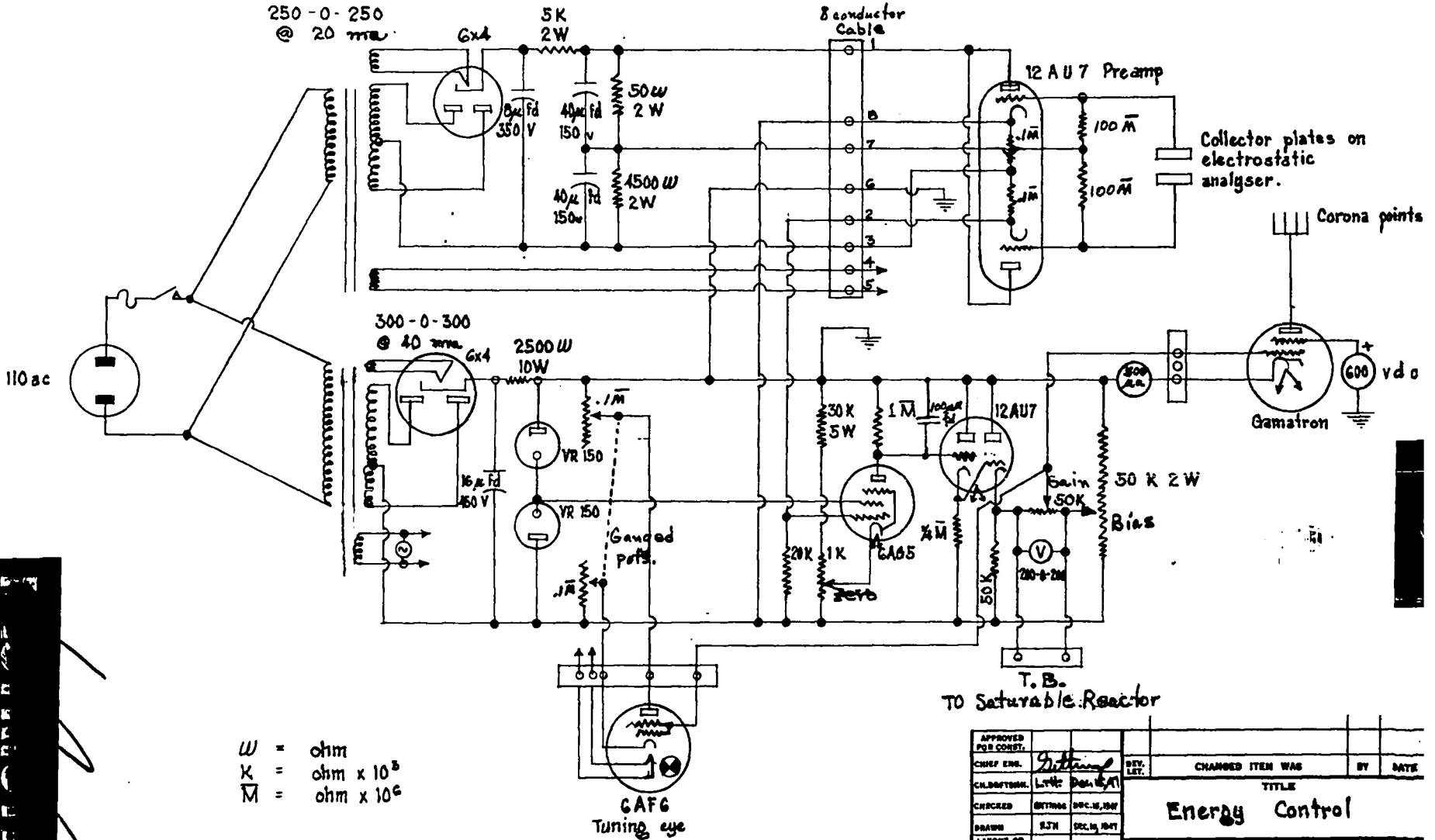

W = ohm
 K = ohm x 10³
 M = ohm x 10⁶

T. B.
 TO Saturable Reactor

APPROVED FOR CONST.		REV. LET.	CHANGED ITEM WAS	BY	DATE
CHIEF ENGR. <i>Gitting</i>					
CLERK/DRG. <i>L.H.C. DeWitt</i>					
CHECKED <i>BTM</i>	DEC 14, 1947				
DRAWN <i>SJM</i>	DEC 14, 1947				
LAYOUT OR SETTER					
GROUP <i>P-3</i>	REPRESENTATIVE <i>BTM</i>				
FRACTIONAL TOLERANCE ± 1/64 UNLESS OTHERWISE NOTED.		SCALE = 1"	DRAWING NO. <i>P3-203</i>	SHEET SIZE AND NO. <i>1</i>	TOTAL <i>B</i>

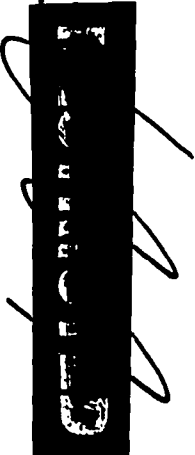

100

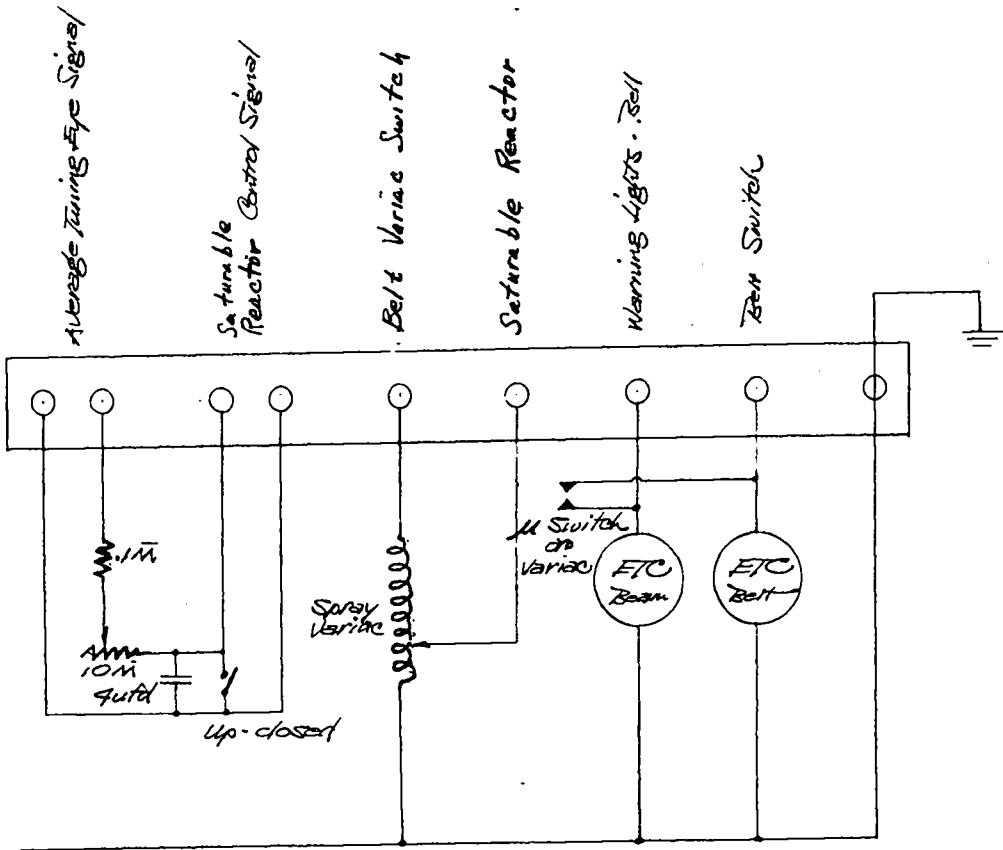

APPROVED FOR CONST.		REV. LET.	CHANGED ITEM WAS	BY	DATE
CHIEF ENGR.	<i>Gitting</i>				
CH. DRFTSMN.	<i>Little Dec. 1947</i>				
CHECKED	<i>WINGS DEC. 15, 1947</i>				
DRAWN	<i>FHS 12/17</i>				
LAYOUT OR SKETCH			TITLE <i>Spray Current Regulator</i>		
GROUP P-5	REPRESENTATIVE GITTING	SCALE = 1"	DRAWING NO. <i>P3-204</i>	SHEET SIZE AND NO. — 1	B
FRACTIONAL TOLERANCE ± 1/64 UNLESS OTHERWISE NOTED.					
TOTAL 1					

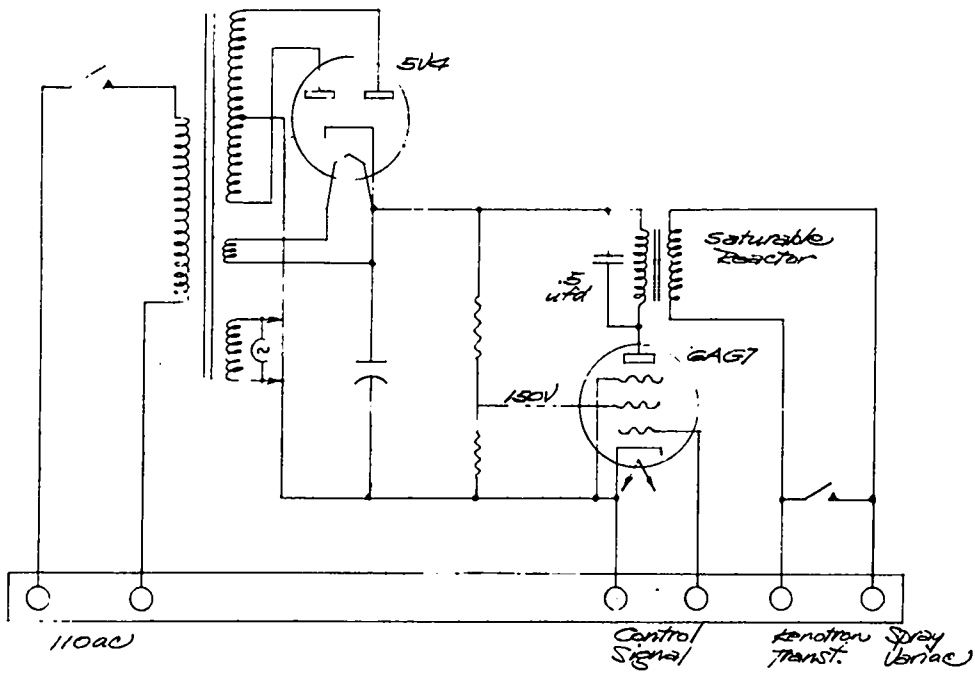

APPROVED FOR CONST.					
CHIEF ENG.			REV. LET.	CHANGED ITEM WAS	BY
CH. DRAFTSMAN			TITLE		
CHECKED	L. H. Dec 16 1947		Saturable Reactor		
DRAWN	J. R. Dec 15 1947				
LAYOUT OR SKETCH					
GROUP	73	REPRESENTATIVE	Gillies		
FRACTIONAL TOLERANCE ± 1/64 UNLESS OTHERWISE NOTED.			SCALE	DRAWING NO.	SHEET SIZE AND NO.
			###	P3-205	-1
			TOTAL 1		

SECRET

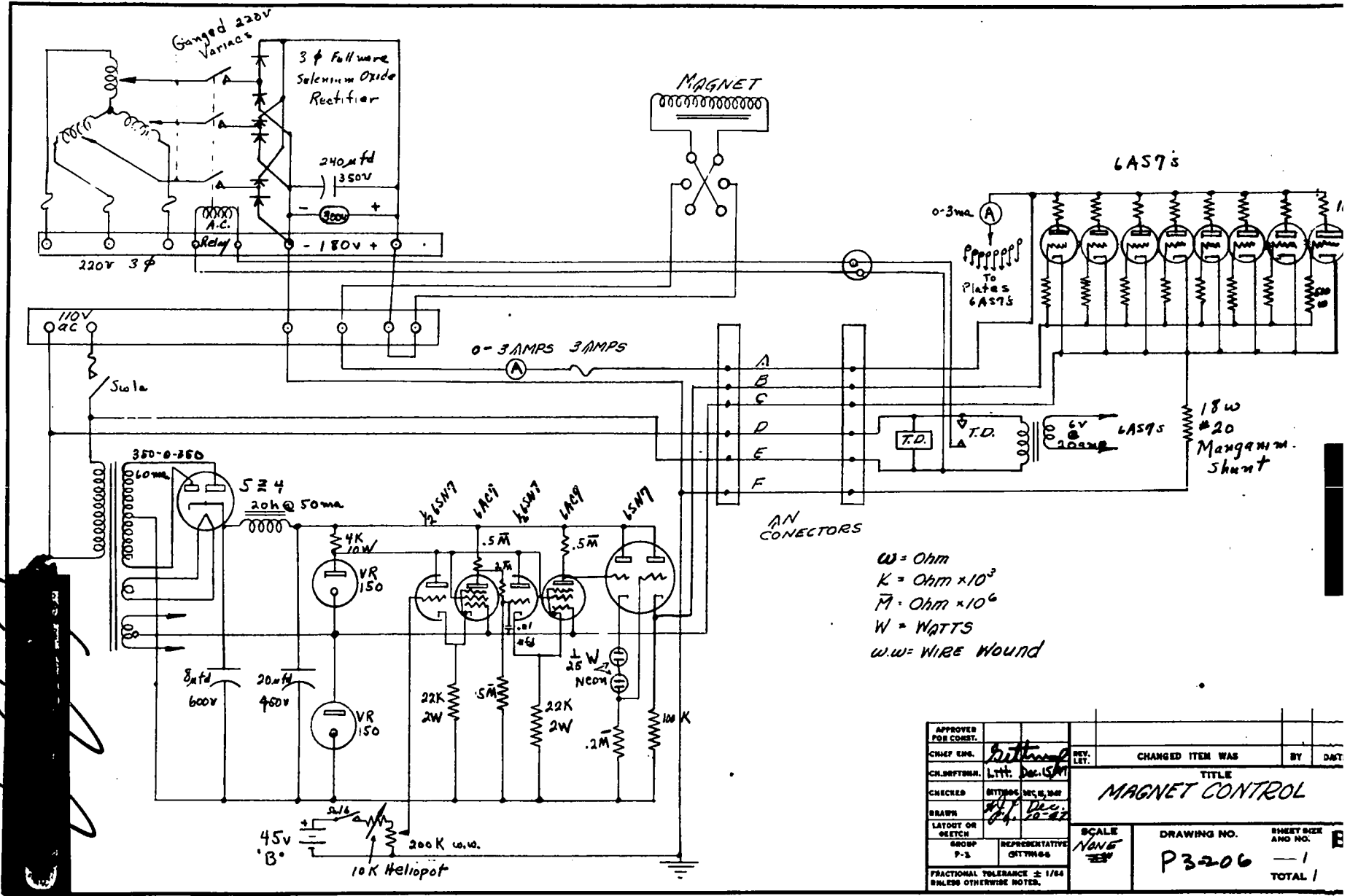

APPROVED FOR CONST.		REV. SET.		CHANGED ITEM WAS	BY	DATE
CHIEF ENG.	<i>Bittner</i>					
CH. DESIGNED	Litt. Dec. 54					
CHECKED	BTM Dec. 54					
DRAWN	BTM Dec. 54					
LAYOUT OR SETTER						
GROUP	P-3	REPRESENTATIVE	BTM			
FRACTIONAL TOLERANCE $\pm 1/64$ UNLESS OTHERWISE NOTED.			SCALE	DRAWING NO. SHEET SIZE AND NO.		
			<i>None</i>	P3-206 - 1		
				TOTAL 1		

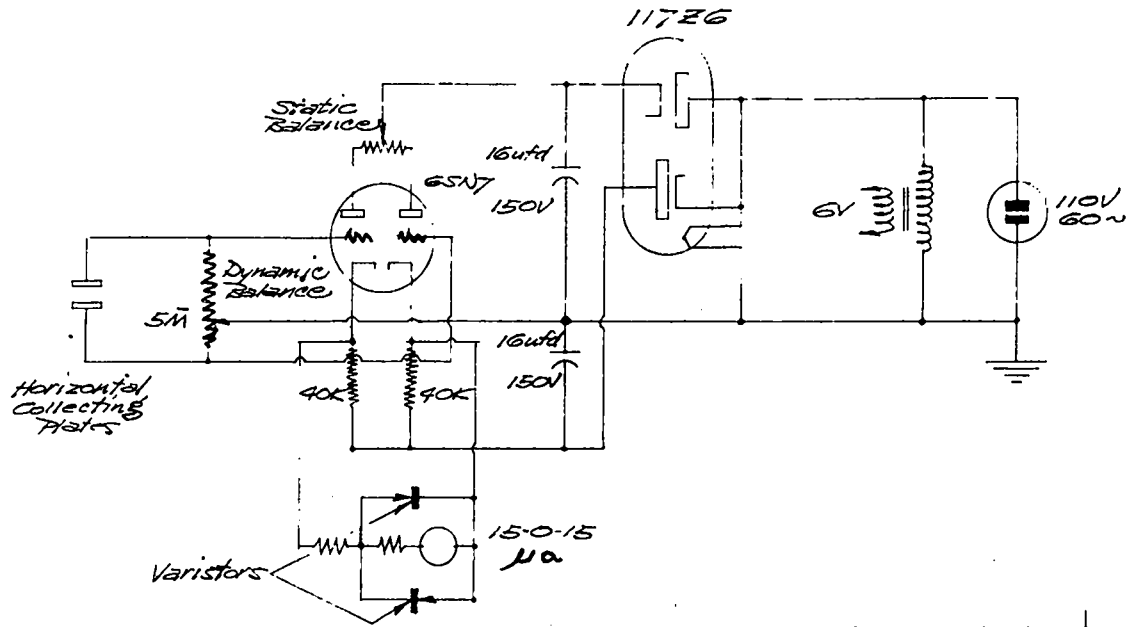

W = Ohm
 K = Ohm X 10³
 M = Ohm X 10⁶

APPROVED FOR CONST.		REV. LET.		CHANGED ITEM WAS	BY	DATE
CHKD ENGR.	<i>Letting</i>					
CH. DEPTEN.	<i>L.M.</i>					
CHECKED	<i>SMITH</i>	DEC. 18, 1947	TITLE			
DRAWN	<i>FR</i>	<i>DEC 18 1947</i>	Horizontal Balance Indicator			
LAYOUT OR SKETCH			SCALE	DRAWING NO.	SHEET SIZE AND NO.	
GROUP	9-5	REPRESENTATIVE	= 1"	P3 207	B	
FRACTIONAL TOLERANCE $\pm 1/64$ UNLESS OTHERWISE NOTED.				- 1	TOTAL 1	

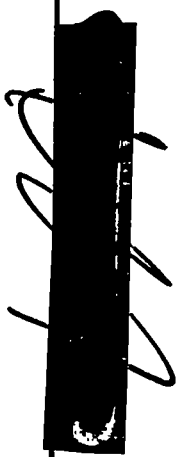

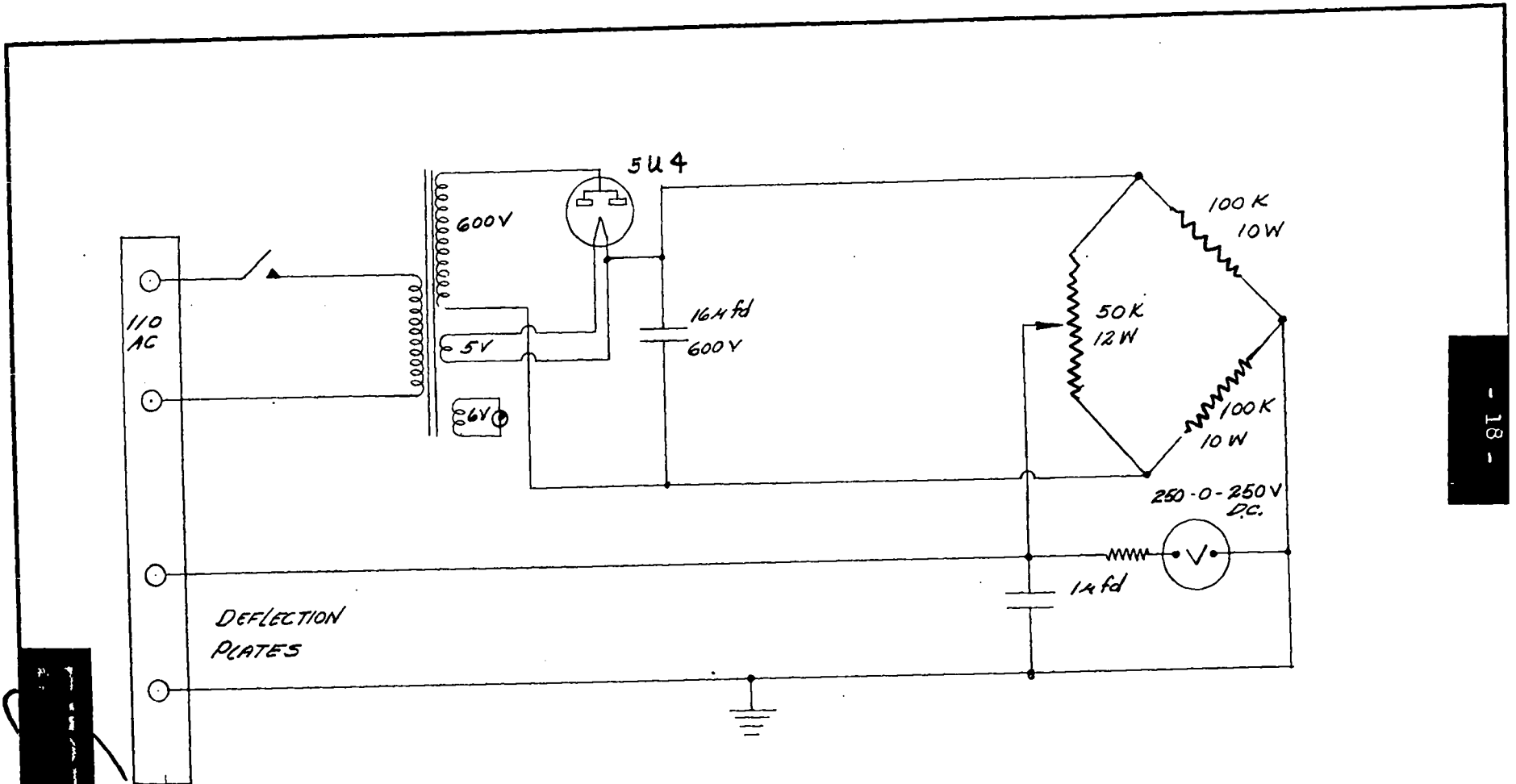

TERMINAL BLOCK

DEFLECTION PLATES

APPROVED FOR CONST.		REV. LET.	CHANGED ITEM WAS	BY	DATE
CHIEF ENG. <i>Gitting</i>					
CH. DRAFTSM. <i>Litt. Del. 5-47</i>			TITLE		
CHECKED <i>OTTING INC. 12-1947</i>			ELECTROSTATIC SHIM		
DRAWN <i>OTT. 5-47</i>					
LAYOUT OR SKETCH		SCALE <i>NONE</i>	DRAWING NO.	SHEET SIZE AND NO.	
GROUP 9-3	REPRESENTATIVE <i>OTTING</i>		<i>P3-208-1</i>	B	
FRACTIONAL TOLERANCE ± 1/64 UNLESS OTHERWISE NOTED.			TOTAL 1		

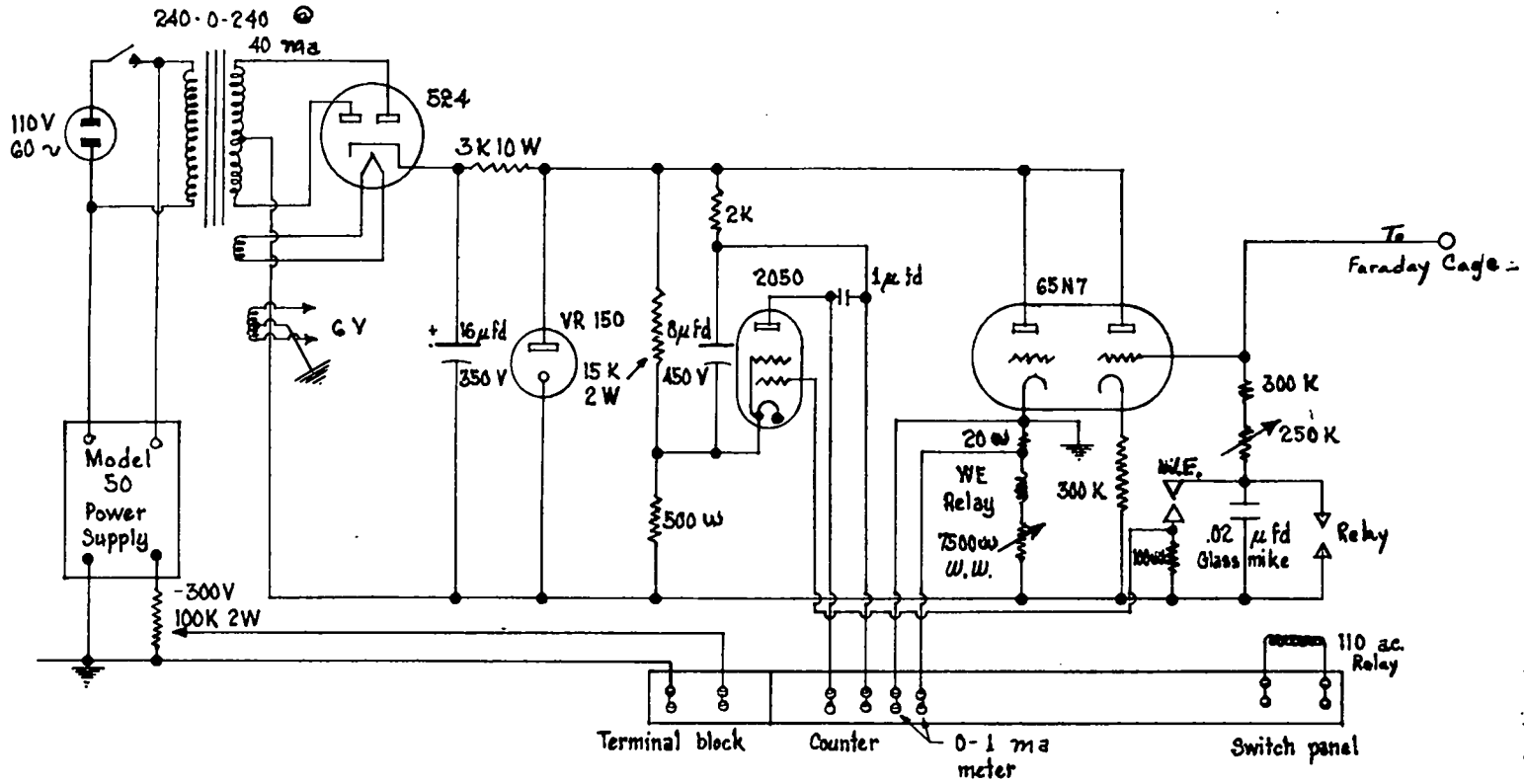

Ω = ohm
 K = ohm $\times 10^3$
 M = ohm $\times 10^2$
 W = watts
 w.w. = wire wound

APPROVED FOR CREDIT:				
CHIEF ENG. <i>B. H. ...</i>	REV. LET.	CHANGED ITEM WAS	BY	IN
CL. DESIGNED <i>L. W. ...</i>				
CHECKED <i>W. T. ...</i>				
DRAWN <i>W. T. ...</i>				
LAYOUT OR SELECT	REPRESENTATIVE	SCALE	DRAWING NO.	SKETCH FILE AND NO.
GROUP P-5	SETTINGS	= 1"	P3-209 - 1	TOTAL 1
FRACTIONAL TOLERANCE $\pm 1/64$ UNLESS OTHERWISE NOTED.				

- 19 -

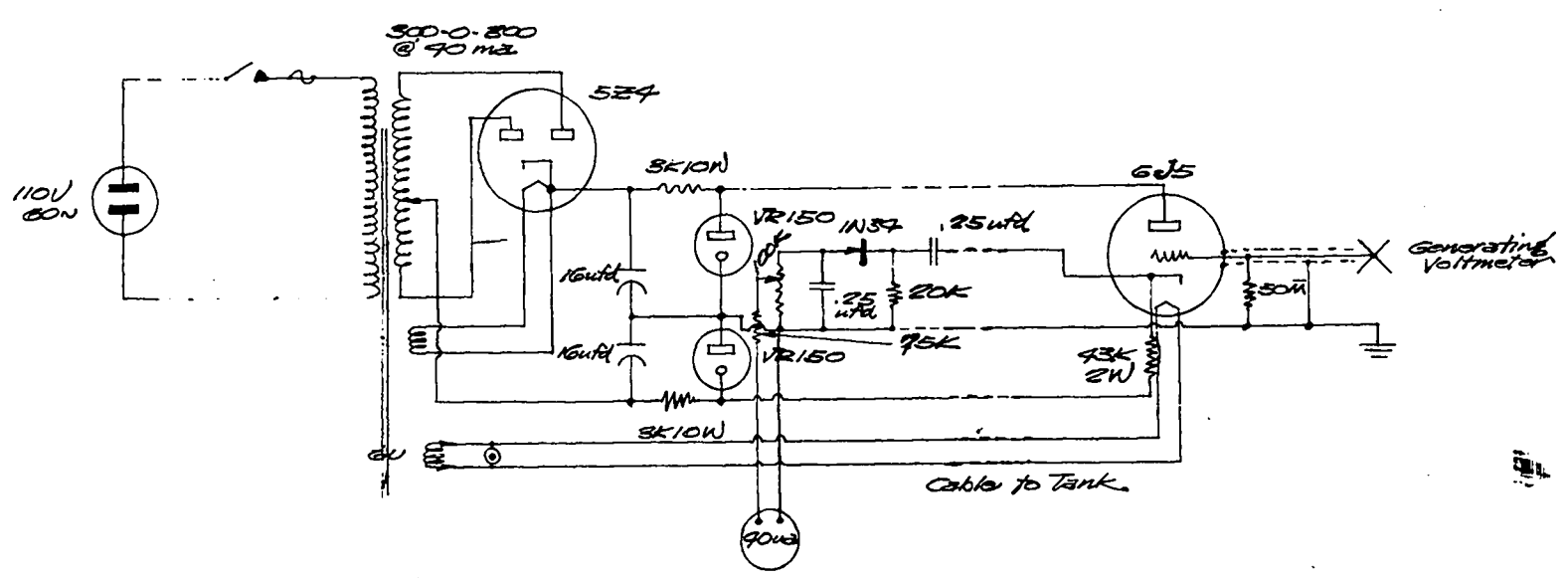

[Handwritten signature]

APPROVED FOR CORRECT.					
CHIEF ENG.	<i>[Signature]</i>	REV. LET.	CHANGED ITEM WAS	BY	DATE
CH. DRFTSMN.	<i>[Signature]</i>	DATE	TITLE		
CHECKED	<i>[Signature]</i>	DATE	<i>Generating Voltmeter</i>		
DRAWN	<i>[Signature]</i>	DATE			
LAYOUT OR SECTED		SCALE	DRAWING NO.	SHEET NO. AND NO.	B
		= 1"	P3-210	- 1	TOTAL 1
FRACTIONAL TOLERANCE ± 1/64 UNLESS OTHERWISE NOTED.					

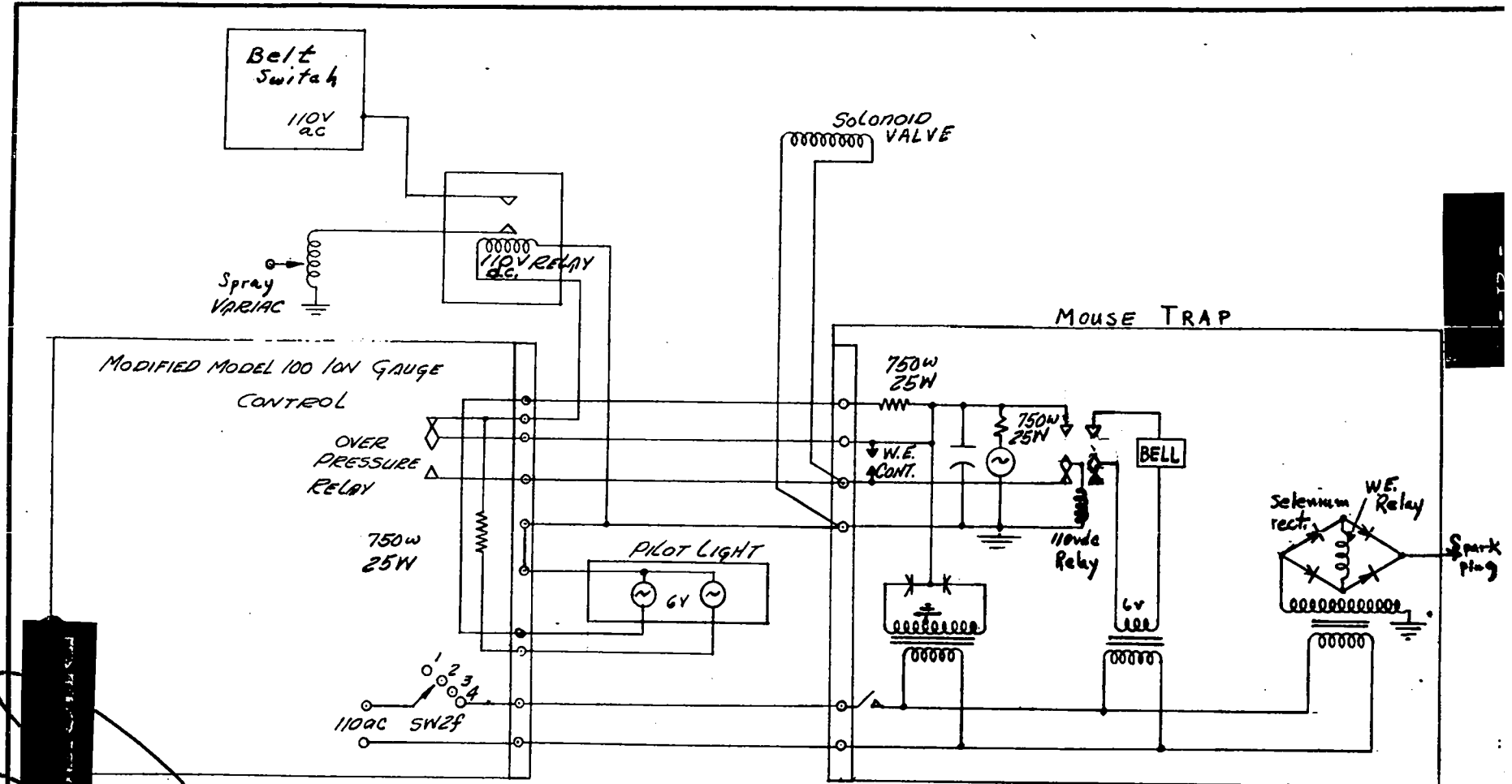

$W = \text{OHM}$
 $K = \text{OHM} \times 10^3$
 $M = \text{OHM} \times 10^6$
 $W = \text{WATTS}$
 $V = \text{VOLTS}$

APPROVED FOR CONST.		REV. LET.	CHANGED ITEM WAS	BY	DATE
CHIEF ENG.	<i>Rittner</i>				
COL. DRFTSM.	W.C. DEC. 1947				
CHECKED	ATTEND DEC 15 1947				
DRAWN	W.C. DEC. 1947				
LAYOUT OR RECHECK		SCALE	DRAWING NO.	SHEET NO. AND OF	DATE
GROUP P-3	REPRESENTATIVE SETTINGS	None	93-211	- 1	B
FRACTIONAL TOLERANCE $\pm 1/64$ UNLESS OTHERWISE NOTED.				TOTAL 1	

TITLE
PROTECTION CIRCUIT

APPROVED FOR PUBLIC RELEASE

APPROVED FOR PUBLIC RELEASE

MODEL 100 10N
GAUGE CONTROL

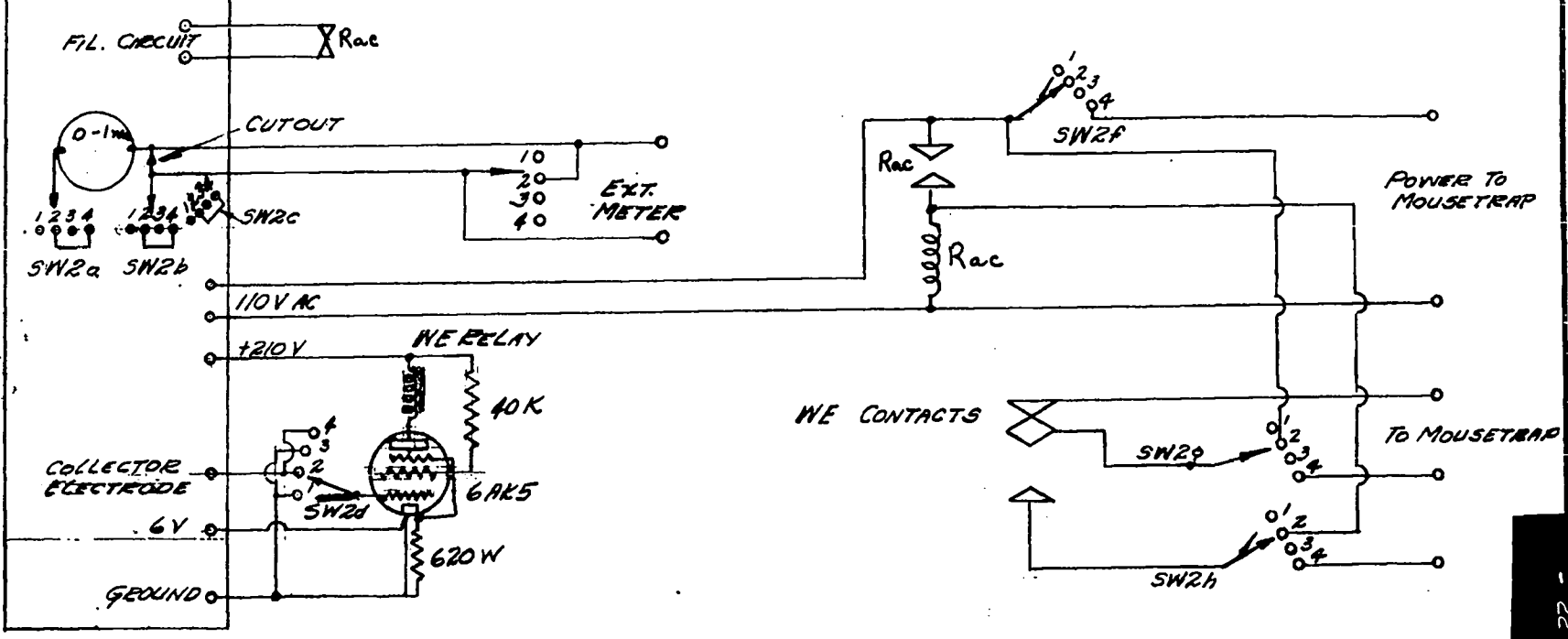

APPROVED FOR COMP.					
CHIEF ENG.	<i>W. J. L.</i>	REV. LET.		CHANGED ITEM WAS	BY DATE
CLERK/TECH.	<i>W. J. L.</i>				
CHECKED	<i>W. J. L.</i>	DATE	<i>DEC 15, 47</i>	TITLE	
DRAWN	<i>W. J. L.</i>	DATE	<i>OCT. 30, 47</i>	MODIFICATIONS	
LAYOUT OR DESIGN				MODEL 100 10N GAUGE CONTROL	
GROUP	7-5	REPRESENTATIVE	<i>HONE</i>	DRAWING NO.	SHEET ONE AND ONE
FRACTIONAL TOLERANCE ± 1/32 UNLESS OTHERWISE NOTED.				<i>P3-212 - 1</i>	B
				TOTAL 1	

W. J. L.

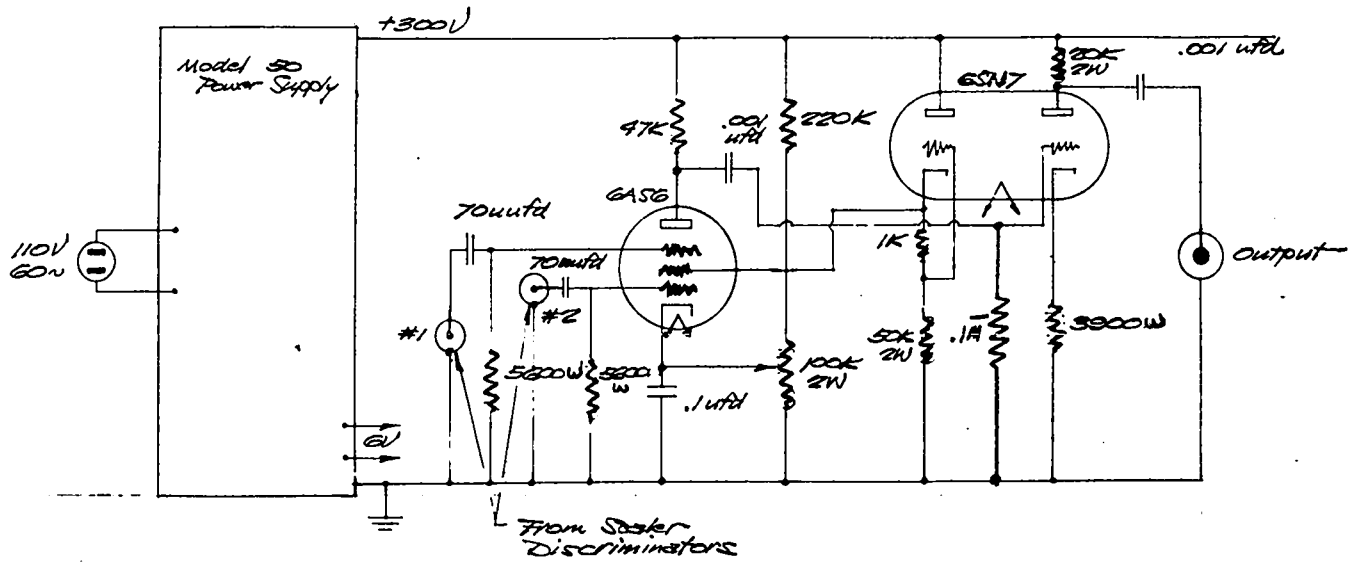

[Handwritten signature]

APPROVED FOR CONST.		REV. LET.	
CHIEF ENGR.	<i>[Signature]</i>	CHANGED ITEM WAS	BY DATE
CL. DIVISION	Lot. 22, 15, 41	TITLE <i>Double Coincidence Circuit</i>	
CHECKED	ATTN: REC 15, 41		
DRAWN	<i>[Signature]</i>	SCALE	DRAWING NO.
LAYOUT OR SEETCH	7-5	= 1"	P35213
REPRESENTATIVE SETTINGS		SHEET SIZE AND NO.	TOTAL
FRACTIONAL TOLERANCE ± 1/64 UNLESS OTHERWISE NOTED.			1

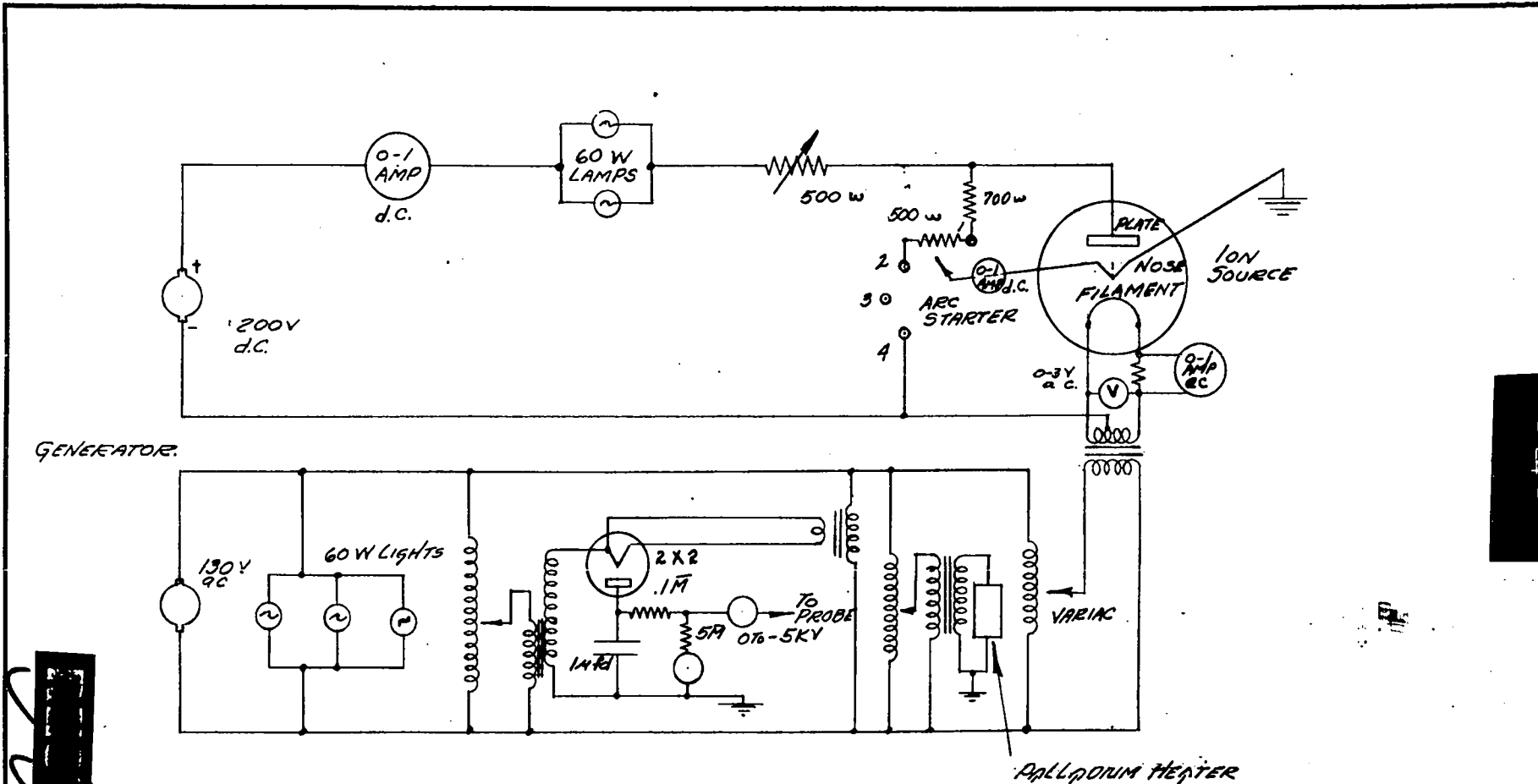

[Handwritten signature]

APPROVED FOR CONST.		REV. LET.	
CHRY ENG.	<i>[Signature]</i>	CHANGED ITER WAR	BY
CH. BARTON	<i>[Signature]</i>	TITLE	
CHECKED	<i>[Signature]</i>	ELECTRODE CIRCUIT HIGH VOLTAGE	
DRAWN	<i>[Signature]</i>	SCALE	DRAWING NO.
LAYOUT OR CHECK		100%	93-214
GROUP	REPRESENTATIVE	SHEET SIZE AND NO.	TOTAL
9-5	Q1111111	1	1
FRACTIONAL TOLERANCE ± 1/64 UNLESS OTHERWISE NOTED.			

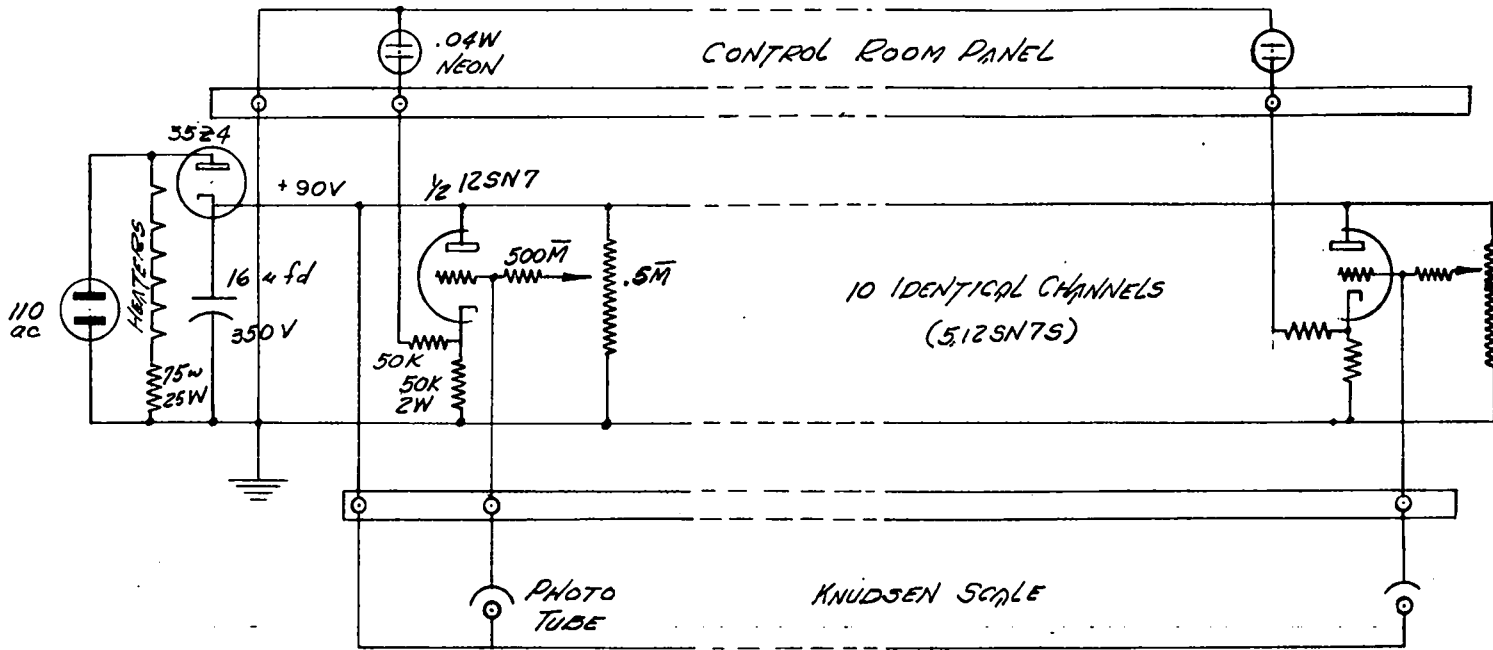

[Handwritten signature]

APPROVED FOR CONST.					
CHIEF ENG.			REV. LET.	CHANGED ITEM WAS	BY DATE
CLERK/DRYER	L.M.	DEC. 16 1947		TITLE	
CHECKED	TR	8-27		KNUDSEN SCALE	
DRAWN	MS	10-27		TELE-METER	
LAYOUT OR SKETCH		15-47		SCALE	
GROUP	P-3		REPRESENTATIVE	DRAWING NO.	SHEET OR NO.
			GITTINGS	P3-215	1
FRACTIONAL TOLERANCE \pm 1/64 UNLESS OTHERWISE NOTED.				TOTAL	1

UNCLASSIFIED

88160

DOCUMENT ROOM

REC. FROM Ed. Div

DATE 2-3-48

REC. NO. REC. _____

UNCLASSIFIED

~~SECRET~~