

LA-6809

C.3

CIC-14 REPORT COLLECTION
**REPRODUCTION
COPY**

UC-34 and UC-45

Issued: July 1977

**An Empirical Model to Compute the
Velocity Histories of Flyers
Driven by Electrically Exploding Foils**

S. C. Schmidt
W. L. Seitz
Jerry Wackerle

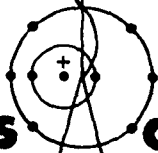

Los Alamos
scientific laboratory
of the University of California
LOS ALAMOS, NEW MEXICO 87545

An Affirmative Action/Equal Opportunity Employer

UNITED STATES
ENERGY RESEARCH AND DEVELOPMENT ADMINISTRATION
CONTRACT W-7403-ENG. 36

Printed in the United States of America. Available from
National Technical Information Service
U.S. Department of Commerce
5285 Port Royal Road
Springfield, VA 22161
Price: Printed Copy \$3.50 Microfiche \$3.00

This report was prepared as an account of work sponsored by the United States Government. Neither the United States nor the United States Energy Research and Development Administration, nor any of their employees, nor any of their contractors, subcontractors, or their employees, makes any warranty, express or implied, or assumes any legal liability or responsibility for the accuracy, completeness, or usefulness of any information, apparatus, product, or process disclosed, or represents that its use would not infringe privately owned rights.

LOS ALAMOS NATIONAL LABORATORY
3 9338 00387 0622

AN EMPIRICAL MODEL TO COMPUTE THE VELOCITY HISTORIES OF FLYERS DRIVEN BY ELECTRICALLY EXPLODING FOILS

by

S. C. Schmidt, W. L. Seitz, and Jerry Wackerle

ABSTRACT

A modification of the gas gun (Gurney) formulation is used to compute the velocity and position histories of flyers driven by electrically exploded metal foils. The model is based on a numerical time integration of an energy conservation statement for the flyer and the expanding high-pressure metal vapor. Empirically altered, experimental power curves are used for the time-dependent energy term in the conservation equation. Computed burst times and flyer velocity histories for 1.5- to 25-mm-square aluminum foils agree favorably with available experimental data. Comparison of calculated and measured results for single cases with exploding copper and magnesium foils suggests that the model is also applicable for these materials.

I. INTRODUCTION

During the past decade, electrically driven flyer systems have evolved into effective laboratory high-pressure shock-wave generators, which are particularly useful for investigations of the short-duration shock initiation of condensed explosives.¹ A typical arrangement for accelerating thin flyers is shown in Fig. 1. A capacitor bank is discharged through a thin metal foil, effecting its abrupt vaporization. This "burst" of the foil generally occurs with a sharp maximum foil resistance and electrical power input. The plastic layer is sheared at the inner radius of the barrel, and the flyer disk so formed is subsequently accelerated by the high-pressure vapor. Flyer velocities as high as 14 mm/ μ s have been achieved in this way.¹

The gas gun (Gurney) approximation is a simple analysis that has been used to predict the motion of plates and shells driven by detonated chemical explosives,²⁻⁴ and recently has been used to treat electrically driven flyers.^{1,9-11} Conceptually, the

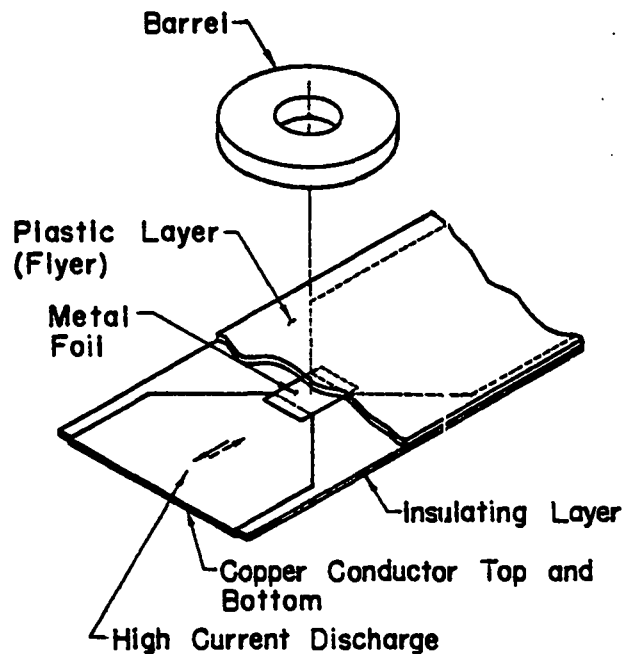

Fig. 1.
Electrically driven flyer assembly.

physical system modeled is the expansion of high-pressure gas, initially at rest, against confining plates or shells. A "Gurney energy" is assumed to be deposited uniformly throughout the gas before any motion begins. This energy is taken as an empirical fraction of the energy of reaction for chemical explosives^{2,8} and has been correlated to the joule heating near burst for electrically exploded foils.^{1,9,11}

For explosively driven flyers, the gas-gun approach predicts flyer-velocity histories that agree favorably with both experimental results and hydrodynamic computer code calculations.^{7,8} Previous application^{1,9,11} of the Gurney formulation to electrically driven flyers has been limited to the calculation of terminal velocities, and has not produced entirely satisfactory results. The standard gas-gun formulation does indeed predict that terminal velocity is achieved in typical run distances; however, a much more gradual and continuing flyer acceleration is observed. Since the corresponding exploding foil power histories measured by us and others^{1,11} suggest additional energy deposition in the metallic vapor subsequent to foil burst, a formulation of the treatment with time-dependent energy deposition is indicated.

In the work described here, a conceptually satisfactory modification of the gas-gun treatment is used to compute velocity histories for flyers driven by electrically exploded foils. Rather than assume instantaneous energy deposition, we empirically relate the joule heating of the foil material to the observed electrical power histories, with allowance for energy dissipated in forming the metal plasma. These changes yield computed velocity histories considerably different from those resulting from the usual Gurney model and in favorable agreement with available experimental data. In many instances, the model also affords reasonable estimates of foil burst time.

The model is strictly empirical. Even though many of the relevant physical processes that occur during foil heating and expansion are used to incorporate the empiricisms, many more processes (e.g., plasma recombination, spatially nonuniform energy deposition) are ignored. The principal improvement over previous models of electrically driven flyers is that a computation of complete velocity histories can be made for a wide range of foil and flyer dimensions.

II. ANALYSIS

A. Simple Gas-Gun Formulation

The usual Gurney model is formulated by the conservation of the total energy (internal and kinetic) of the driving gas-flyer system. Initially, the system is at rest and, with compression and internal energy of the flyer neglected, the total energy is the internal energy of the gas. This Gurney energy, E_g , is assumed to be generated instantaneously from an explosive reaction or from electrical heating of a foil vapor. In the subsequent expansion of the gas, the internal energy, E , density, ρ , and pressure, p , are taken to be spatially uniform. The mass velocity, u , is assumed to vary linearly with distance, r , in the gas and to have the uniform value u_f in the flyer.

For electrically driven flyers, slab geometry with the vapor sandwiched between the flyer and an infinitely massive tamper is assumed. With the above assumptions, the energy conservation statement is

$$m_g E(t) + \frac{\rho(t)}{2} \int_0^{r_f(t)} u^2(r, t) dr + \frac{1}{2} m_f u_f^2(t) = m_g E_g \quad (1)$$

where m_g and m_f are the gas and flyer masses per unit area and r_f the position of the gas-flyer interface. With $u(r, t) = (r/r_f(t))u_f(t)$ (and noting that $\rho(t)r_f(t) = m_g$), this expression reduces to

$$E + \frac{1}{2} \left(\frac{1}{3} + \mathcal{R} \right) u_f^2 = E_g \quad (2)$$

where $\mathcal{R} = m_f/m_g$. Assuming that the equation of state of the vapor is that of a polytropic gas,

$$E = \frac{p}{(\gamma - 1)\rho} = \frac{3}{2} \frac{p}{\rho} \quad (3)$$

where the gas constant, $\gamma = 5/3$, is chosen on the assumption that the metal is monatomic. When the pressure is considered as an accelerating force exerted per unit area of the flyer,

$$p = m_f \frac{du_f}{dt} \quad (4)$$

the internal energy can be eliminated from Eq. (2), yielding

$$\frac{3}{2} \alpha r_f \frac{du_f}{dt} + \frac{1}{2} \left[\frac{1}{3} + \alpha \right] u_f^2 = E_g \quad (5)$$

The transformation $du_r/dt = 1/2(du_r^2/dr_r)$ converts Eq. (5) to a first-order differential equation for $u_r^2(r_r)$, which can be integrated from the initial gas-flyer interface position, r_g , to an arbitrary final position, r_r , to give

$$u_f = \left[\frac{2 E_g}{(1/3 + \alpha)} \left[1 - (r_g/r_r)^\phi \right] \right]^{1/2} \quad (6)$$

where $\phi = 2/3 + 2/(9\alpha)$. As the flight distance becomes much larger than the foil thickness, $r_r \gg r_g$, a terminal velocity

$$u_{fc} = \left[\frac{2 E_g}{(1/3 + \alpha)} \right]^{1/2} \quad (7)$$

is attained.

As mentioned earlier, previous applications of the Gurney method to electrically driven flyers have all been made on the basis of a terminal velocity such as that expressed in Eq. (7).^{1,9-11} The Gurney energy was correlated to the burst current density, J_b , in the form

$$E_g = K J_b^n \quad (8)$$

where K and n were empirically determined constants for a given foil material and for velocity measurements at a specified flight distance. This model successfully predicts the flyer velocity dependence on the burst current density and flyer thickness and is adequate if these are the only parameters to be varied.

The consideration of only the terminal velocity for electrically driven flyers is consistent with the assumption of the simple model. For typical configurations and flight distances of interest, the input parameters to Eq. (6) would be $\phi \cong 1$ and $r_g/r_r \cong 0.01$, and terminal velocity is nearly achieved. However, under these conditions terminal velocities are not usually observed. For example, the velocity history measurement of Weingart and coworkers¹ (Fig. 2, curve B, of the present report) has a much more gradual acceleration than the trajectory, B', calculated with the Gurney method and the burst-current correlation. Similar comparisons occur when

the simple analysis is applied to the other flyer/foil assemblies described here.

The failure of the flyer to reach a terminal velocity as quickly as predicted can be understood by examining the power curves for the exploding foils, such as curve A in Fig. 2. Contrary to the instantaneous energy deposition at burst, which is assumed when using the Gurney model, the actual power deposited is not sharply peaked near the time of burst, but exhibits a moderately fast rise to peak power and a more gradual decay after burst. The gradual decay suggests that joule heating of the foil is still occurring at relatively large postburst times. Addition of energy to the expanding gas would sustain a greater gas pressure than expected from the simple model, and would lead to a continuing acceleration of the flyer. Thus the energy conservation statement should be formulated with a time-dependent energy deposition term to allow closer agreement with experimental power curves.

B. Time-Dependent Energy Deposition

If the constant Gurney energy, E_g , is replaced by a time-dependent deposited specific energy, $Q(t)$, the conservation statement, Eq. (5), can be rewritten as

$$\frac{du_f(t)}{dt} = \frac{1}{3\alpha r_f(t)} \left[-\left(\frac{1}{3} + \alpha\right) u_f(t)^2 + 2Q(t) \right] \quad (9)$$

Initial conditions for the integration are $Q(0) = u_r(0) = 0$ and $r_r(0) = r_g$. With $Q(t)$ specified by observed power histories, a numerical solution is necessary. Specifically, the set of three coupled differential equations, Eq. (9),

$$\frac{dr_f(t)}{dt} = u_f(t) \quad (10)$$

and

$$\frac{dQ(t)}{dt} = P(t) \quad (11)$$

are integrated numerically using LASL TLIB Subroutine ODE. The power history, $P(t)$, is derived from a separate analysis of foil current and voltage measurements and a fifth-order polynomial interpolation scheme (LASL TLIB Subroutine AK-NINT). Initial calculations indicated a need to

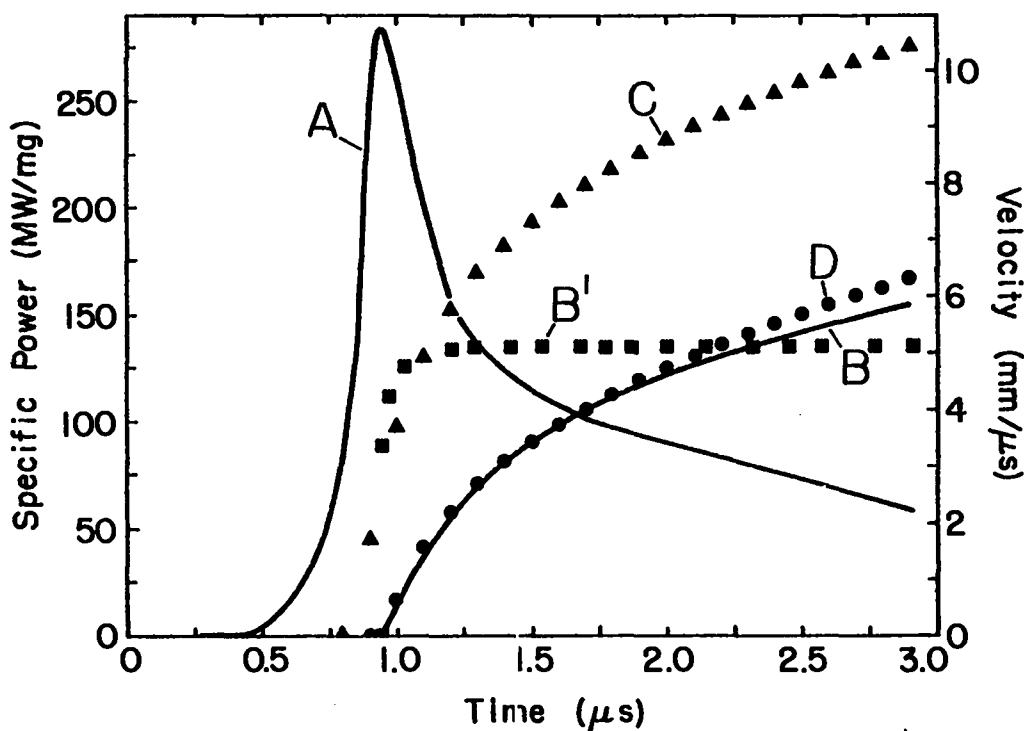

Fig. 2.

Flyer velocity and foil power vs time; 0.051-mm-thick, 25.4-mm-square aluminum foil; 0.25-mm-thick, 25.4-mm-diam Mylar flyer; 40-kV discharge voltage. Curve A, experimental power history. Curve B, experimental velocity history. Curve B', computed velocity history using Gurney model. Curve C, computed velocity history using unaltered postburst power history. Curve D, computed velocity history using modified postburst power history.

reduce the actual power input. The reduction is accomplished by empirical fitting.

III. EMPIRICAL FITTING

The analysis is carried out with the aid of two empiricisms: (1) a preburst energy, I , empirically chosen as the sum of the heats of fusion, vaporization, and ionization, is subtracted from the experimental power curve so that $Q(t) = 0$ in Eq. (8) until the $\int P(t)dt = I$, and (2) modification of the postburst portion of the power curve so that predicted velocity histories agree with measurements.

A. Energy Used for Fusion, Vaporization, and Ionization

The first empiricism is suggested from experimental velocity and power histories. As noted in Fig. 2, flyer movement starts very close to the time of peak power or foil burst, implying that energy deposited in the foil before burst does not contribute directly to flyer acceleration. Foil melting, vaporization, and ionization are possible dissipative processes to absorb this energy.* As a first approximation, I was set equal to the sum of the heats of fusion, vaporization,

*The actual heating path may not include a pressure-volume state which allows for a vaporization transition.

and ionization at atmospheric pressure; values for the three foil materials of interest are given in Table I.

Calculations were performed for experiments by Weingart and coworkers¹ and by Stanton¹¹ by using their measured power curves and the $I = 32.3$ J/mg value for aluminum, with the results given in Figs. 2 and 3. In both cases, 32.3 J/mg corresponded to the integration of the specific power (curve A) to a time near burst. In both instances, the calculated velocity histories (labeled C) gave times of flyer movement coinciding with both the times of initial motion observed (curves B) and the times of peak power in the foils. Following burst, the predicted flyer velocity histories have the correct shape, but are considerably larger than those observed. This disagreement dictates a further modification of power input, $P(t)$.

B. Modified Power History

Even though the correction is empirical, some rationale for a modification of the measured power histories can be argued. Following burst, the material accelerating the flyer is a highly ionized, highly conductive plasma; however, a region of higher resistance liquid and un-ionized vapor must exist between the plasma and the solid lead (see Fig. 4). Because voltage probes must be positioned so that the melt/vapor transition region is included in the measurement, the electrical resistance and power observed do not properly reflect the energy dissipated in the plasma.

Another source of disagreement between theory and experiment is the assumption of an infinitely massive tamper in the development of Eq. (9) so that the kinetic energy (and velocity) of the flyer is not diminished by the kinetic energy of tamper material. This assumption is unrealistic, particularly during the period just following burst, when pressures of several gigapascals are estimated in the foil plasma. A calculation to correct for this effect was made with a "growing tamper" model, in which the mass per unit area of the confining tamper material was assumed to be zero at burst and to subsequently increase according to its density multiplied by its characteristic sound speed. Appropriate modification of the energy conservation relation and explicit use of momentum conservation gave a tractable problem, and calculated velocity histories had the expected improved agreement with observation. Still, the need for a large empirical correction remained; consequently, we included the effect of tamper motion in a correction rather than employing the more complicated formulation of the growing tamper model.

A correction factor applied to the postburst power density was chosen to force agreement for cases with 25.4- and 9.53-mm-square aluminum foils (Figs. 2 and 3). The form used was

$$\text{Correction Factor} = [0.958 - 0.166 W] \times \left[1.0 + \delta - \frac{\delta}{T}\right]^{3.0} \quad (12)$$

Here W is the width of the foil in millimeters, T is the time from foil burst (calculated as described above), and δ is chosen as $0.1 \mu\text{s}$ for the large foils

TABLE I
MATERIAL PROPERTIES OF FOIL METALS
(Taken from Ref. 12)

| Material | Density (mg/mm ³) | Heat of Fusion (J/mg) | Heat of Vaporization (J/mg) | Heat of Ionization (J/mg) |
|-----------|----------------------------------|-----------------------------|-----------------------------------|---------------------------------|
| Aluminum | 2.79 | 0.40 | 10.5 | 21.4 |
| Magnesium | 1.74 | 0.37 | 5.42 | 30.3 |
| Copper | 8.89 | 0.21 | 4.80 | 11.7 |

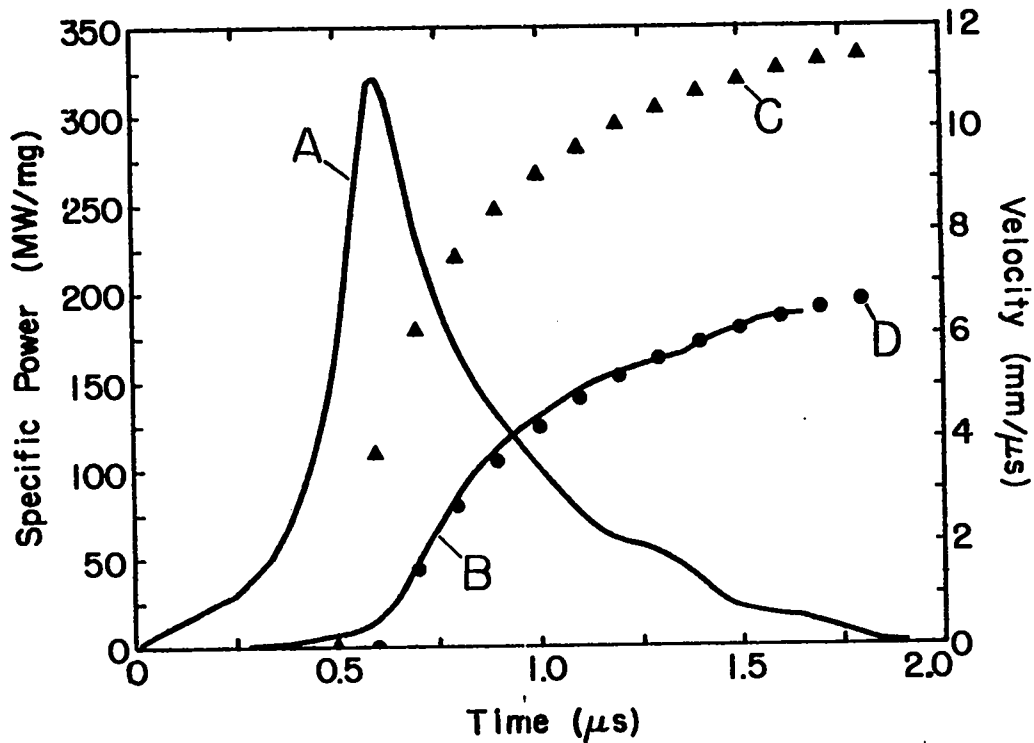

Fig. 3.

Flyer velocity and foil power vs time; 0.051-mm-thick, 9.53-mm-square aluminum foil; 0.127-mm-thick, 9.53-mm-diam Mylar flyer; 18-kV discharge voltage. Curve A, experimental power history. Curve B, experimental velocity history. Curve C, computed velocity history using unaltered postburst power history. Curve D, computed velocity history using modified postburst power history.

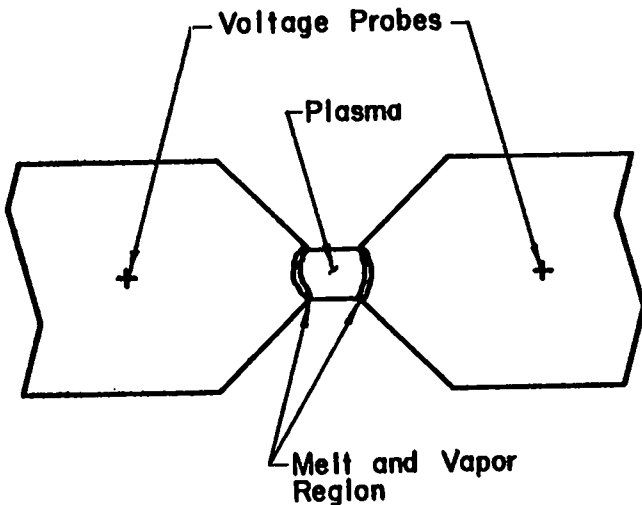

Fig. 4.

Melt and vapor region of exploding foil.

under discussion and 0.025 μs for the smaller foils described later. The results of applying this postburst correction factor are shown by curves D in Figs. 2 and 3. Although the results are superior to those obtained with the simple Gurney formulation, the real test of the model is its ability to simulate velocity histories for foil/flyer geometries much different from those used to calibrate the empirical correction factor.

IV. COMPARISON OF MODEL WITH ADDITIONAL EXPERIMENTAL DATA

In this section the empirical fit structured above is applied to a variety of different foil/flyer configurations to validate its usefulness as a predictive tool

and also to determine, as well as possible, its range of applicability.

A. Large Aluminum Foil Data

Weingart and coworkers^{1,18} have studied flyers driven by aluminum foils of different dimensions and exploded with different firing-set voltages. Figures 5A and 5B give an experimental power history and a single velocity datum¹⁸ for a foil/flyer configuration and discharge voltage similar to that given in Fig. 2, except that the aluminum foil thickness has been increased by a factor of 3. Also shown are the predicted velocity history and the velocity-distance dependence computed using the empirical fit discussed above. Both the computed velocity and the estimated burst time agree favorably with experimental results. Even though the exploding foil for this case has tripled in thickness from the example shown in Fig. 2, the postburst velocity histories of the two configurations are comparable. The specific power in the thinner foil is considerably greater than in the thicker foil, but the total energy deposited is approximately the same for the two configurations. The thicker foil requires more time and three times the electrical energy to burst, but since I is a relatively small fraction of the total electrical input energy, the velocities attained are comparable. This again emphasizes the importance of considering the post-burst power input.

Figures 6A and 6B show a power history and single velocity¹⁸ datum for a foil/flyer configuration in which the foil width is half that of the configuration of Fig. 2 and the capacitor discharge voltage is also decreased by the same factor. As can be seen from the predicted velocity history, a good estimate of the foil burst time is obtained because initial flyer movement occurs at approximately the time of peak power. Figure 6B also shows that the velocity computed using the empirical model agrees favorably with the measured velocity.

B. Large Magnesium and Copper Foils

To assess the model's range of validity, it was compared with Stanton's¹¹ observations of flyers

driven by electrically exploded magnesium and copper foils with geometries and firing-set conditions similar to those of the aluminum foil experiment (Fig. 3). The empirical postburst specific power correction, calibrated using the aluminum foil observations, was applied to the cases of magnesium and copper foils.

The predicted velocity history for the magnesium foil (Fig. 7) is in reasonable agreement with observation—the small discrepancy being due mainly to the calculated later start for the flyer motion. This disagreement occurs despite the fact that the computed burst time corresponds to the peak in the power history.

For the copper foil, the computed flyer velocity history (Fig. 8, curve C), predicts a burst time and initial flyer motion that occur considerably later than the peak in the power history or initial measured flyer movement. If the ionization energy of copper is not included in the determination of I , the computed velocity history (curve D) agrees with that observed. Conceivably, the lower specific power might provide some argument for assuming incomplete ionization of the foil; however, this deduction should be accepted with caution because of the highly empirical character of the analysis.

C. Small Aluminum Foil Data

We have measured velocity, current, and voltage histories for seven 1.52-mm-diam Mylar flyers driven by 0.011-mm-thick, 1.52-mm-square aluminum foils. A 2- μ F capacitor discharge unit, charged to 3 kV, was used to explode the foils. Four tests were fired with 0.75-mm-long, 1.52-mm-diam barrels attached to the Mylar surface (see Fig. 1). Velocities at the end of the barrels were determined from streak-camera records of the flyers striking \sim 0.15-mm Lucite step flashers. The other three experiments were performed without barrels, with velocity histories obtained using a modification of the streak-camera reflection technique.¹⁴ Flyer motion was recorded by observing, at an oblique angle, the light emitted from the exploding foil and transmitted through uncoated slits on the flyer surface. Barrels were not used in these experiments because they would partially obscure the flyer surface at small travel distances. In the absence of a fiducial

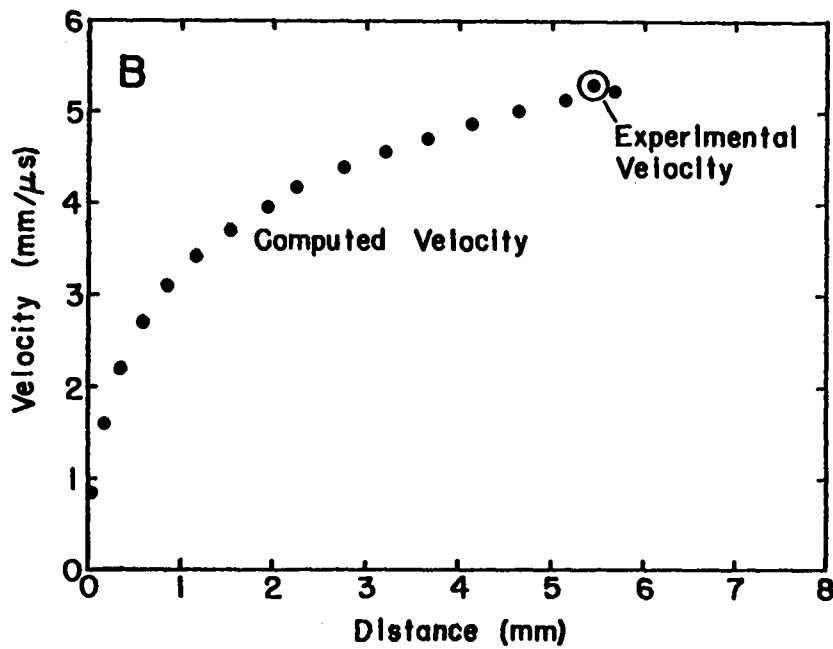
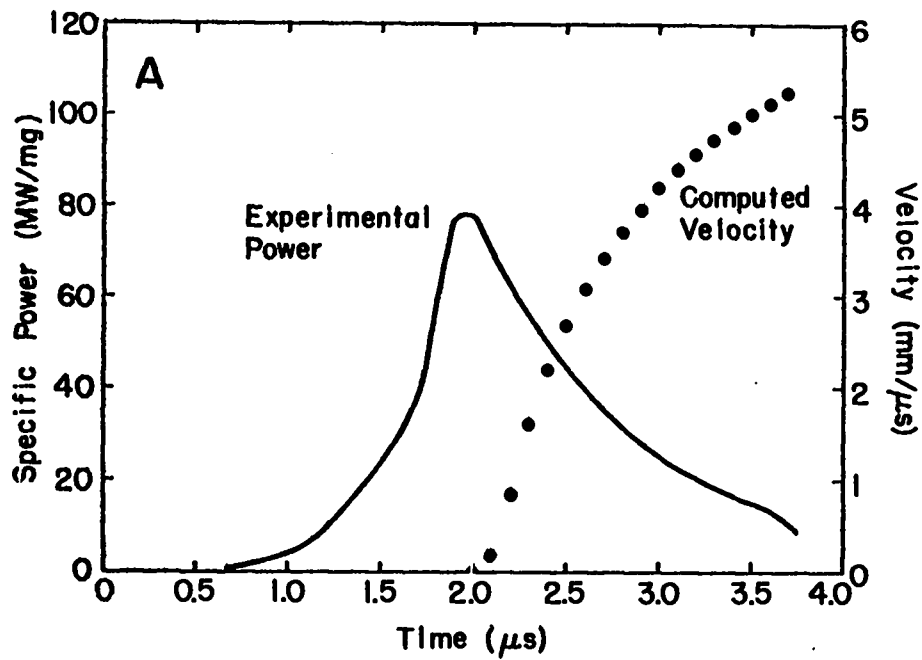

Fig. 5.
 Flyer velocity and foil power vs time (Fig. 5A) and flyer velocity vs travel distance (Fig. 5B);
 0.152-mm-thick, 25.4-mm-square aluminum foils; 0.25-mm-thick, 25.4-mm-diam Mylar
 flyers; 40-kV discharge voltage.

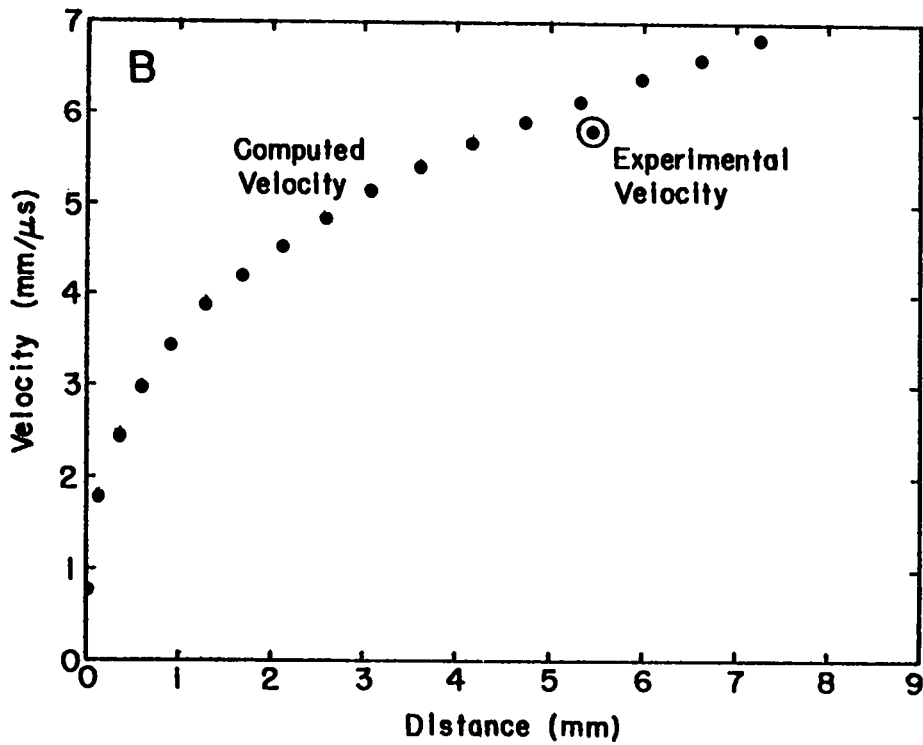
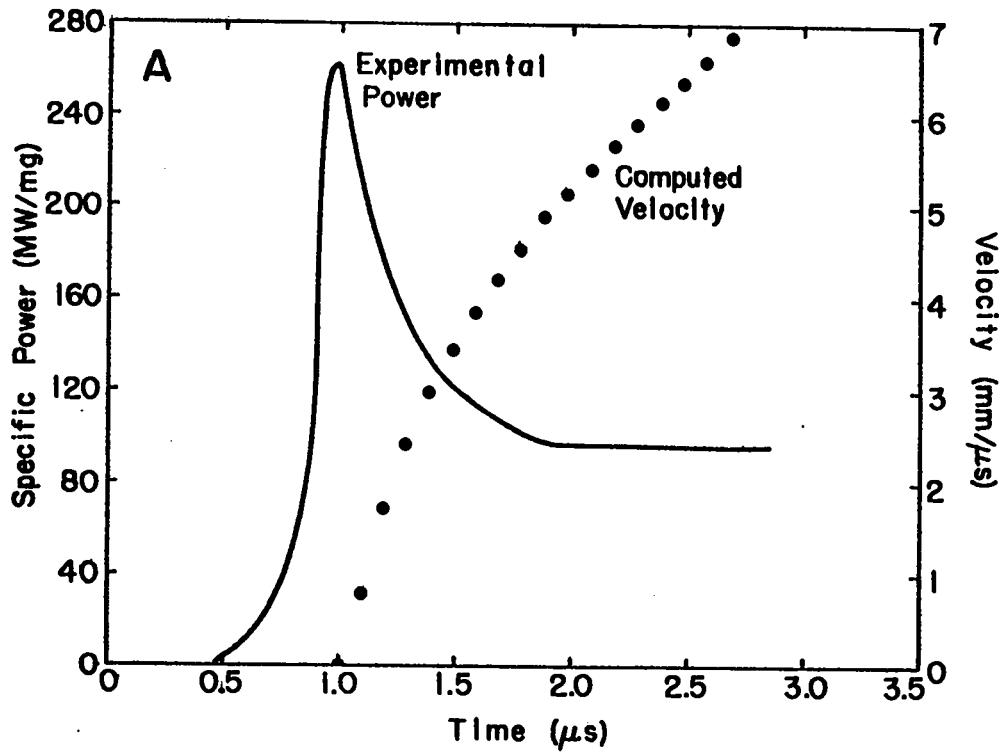

Fig. 6.
 Flyer velocity and foil power vs time (Fig. 6A) and flyer velocity vs travel distance (Fig. 6B);
 0.051-mm-thick, 12.7-mm-square aluminum foils; 0.25-mm-thick, 12.7-mm-diam Mylar
 flyers; 20.4-kV discharge voltage.

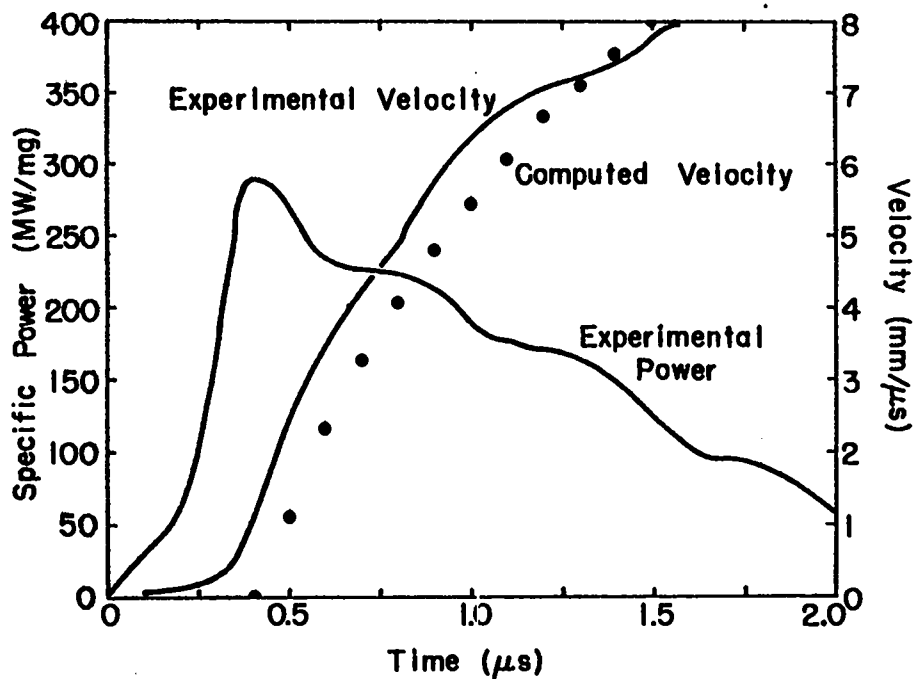

Fig. 7.

Flyer velocity and foil power vs time; 0.051-mm-thick, 6.35-mm-square magnesium foil; 0.127-mm-thick, 6.35-mm-diam Mylar flyer; 18-kV discharge voltage.

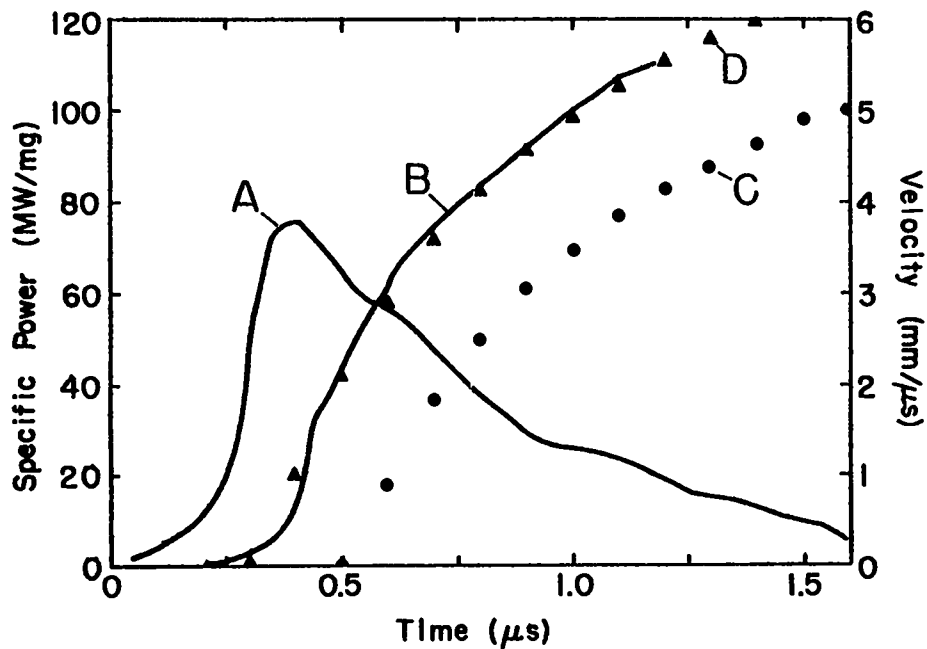

Fig. 8.

Flyer velocity and foil power vs time; 0.036-mm-thick, 9.53-mm-square copper foil; 0.127-mm-thick, 9.53-mm-diam Mylar flyer; 18-kV discharge voltage. Curve A, experimental power history. Curve B, experimental velocity history. Curve C, computed velocity history including ionization energy. Curve D, computed velocity history not including ionization energy.

on the streak-camera film, the electrical current and voltage records were related to the optical observations by correlating the maximum in the voltage measurement with the first observation of light from the bursting foil.

The velocity and specific power histories and the change of velocity with travel distance deduced from the above data for 0.025-, 0.051-, and 0.127-mm-thick flyers are given in Figs. 9 and 10. The different velocity curves correspond to the measurements at different points on the flyer surface. The initial velocity of each of the flyers corresponds to the measured velocity at the time sufficient light is first observed from the bursting foil. Because all three unconfined flyers were first observed with a nonzero initial velocity, these histories have been shifted $0.05 \mu\text{s}$ to the right of estimated foil burst time. The estimated error for the velocity measurements is approximately $\pm 10\%$, except for small travel times and distances which have somewhat larger errors.

The calculated velocity histories and velocity-distance relationships agree with observations to within experimental error, even though the calibration of the specific power correction factor was made using much larger foil configurations. The agreement for the small systems could be improved further by altering the empirical correction factor to match the small-foil data.

The step-flasher measurements taken with barrel assemblies agree within experimental error with the reflection technique observations taken without barrels and with the computed velocities. However, the suggestion that the confining effect of barrels is unimportant should be accepted with caution.

Because the specific power histories in Fig. 9 differ slightly, the flyer thickness, d , is the principal parameter varied in this series of experiments. Observed late-time velocities are roughly proportional to $\sqrt{I/d}$, so that the simple gas-gun model, us-

ing a correctly selected Gurney energy, would appear to provide a decent approximation for this particular parameter variation. However, terminal velocities computed with Eqs. (7) and (8), using measured burst currents and constants calibrated to large aluminum foils, are larger by a factor of 2 than those observed experimentally.

V. SUMMARY

A version of the gas-gun (Gurney) model that allows continuous electrical energy deposition has been developed and used to calculate velocity histories of flyers driven by electrically exploded foils. The time-dependent energy input is related to observed power histories, with a semi-empirical treatment of the energy required to form the foil material plasma and a purely empirical correction of the postburst contribution. Agreement with experiment is obtained for aluminum-foil systems varying by an order of magnitude in foil and flyer dimensions and for assemblies with magnesium and copper foils. Presumably, the tested range of applicability of the model can be extended to include a greater variety of geometrical configurations and other flyer and foil materials.

ACKNOWLEDGMENTS

The authors are indebted to Richard Weingart and Richard Jackson of Lawrence Livermore Laboratory for the large-foil, step-flasher velocity and power history data used in this work. Special thanks go to Robert Mowrer for his assistance with the small-foil experiments and other aspects of the work. We also appreciate the support efforts of Beverly Clifford and William Hicks.

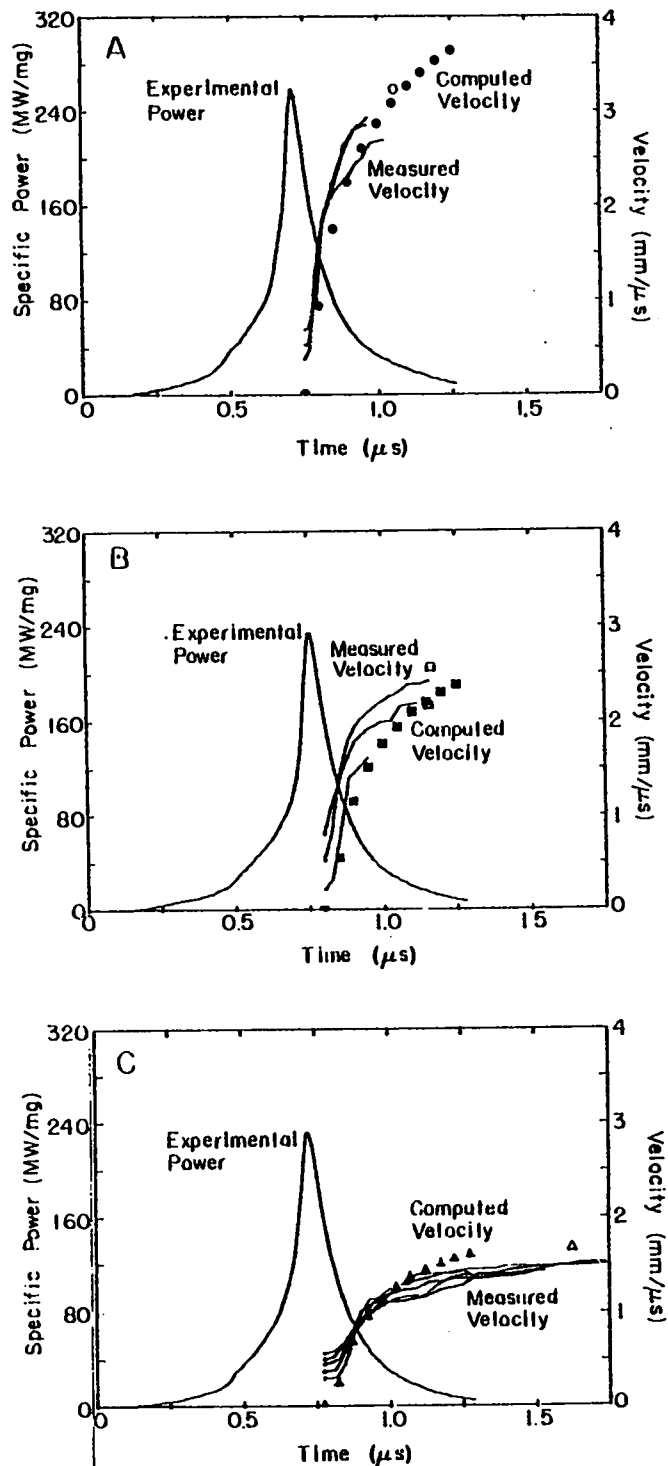

Fig. 9.

Flyer velocity and foil power vs time; 0.011-mm-thick, 1.524-mm-square aluminum foils; 1.524-mm-diam Mylar flyers; ~ 3 -kV discharge voltage.

Figure 9A, 0.025-mm-thick flyer; open circle indicates step flasher data.

Figure 9B, 0.051-mm-thick flyer; open squares indicate step flasher data.

Figure 9C, 0.127-mm-thick flyer; open triangle indicates step flasher data.

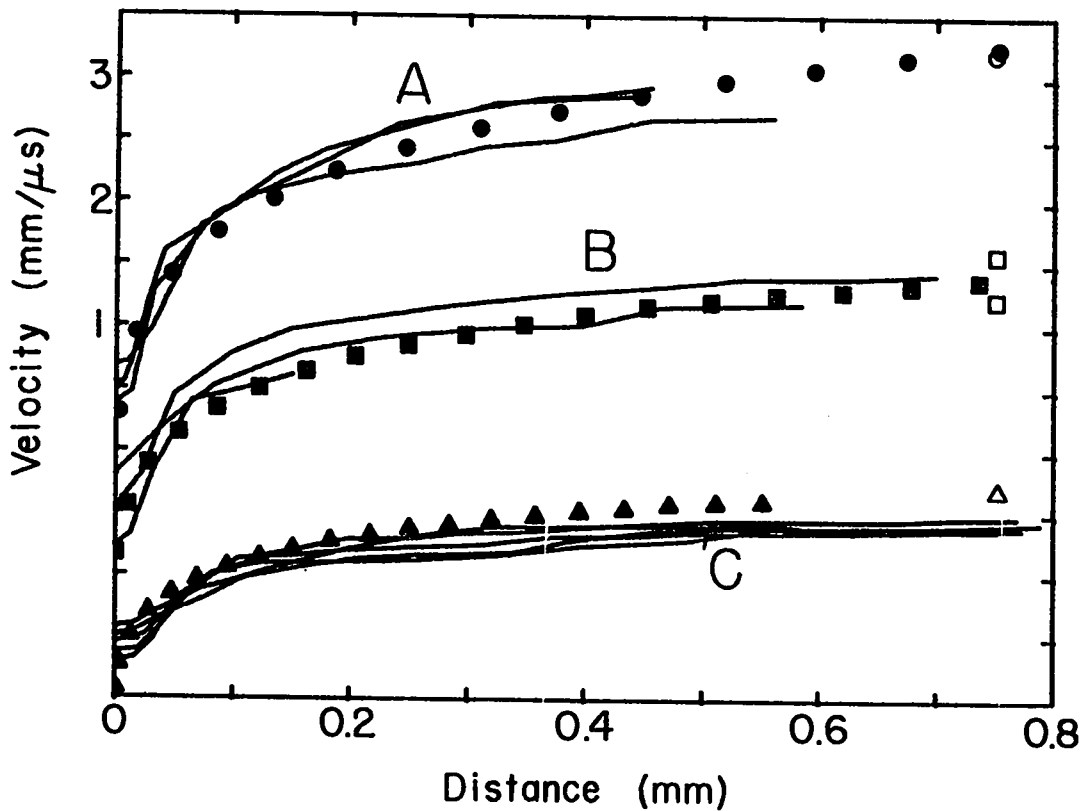

Fig. 10.

Flyer velocity vs travel distance; 0.011-mm-thick, 1.524-mm-square aluminum foils; 1.524-mm-diam Mylar flyers; 3-kV discharge voltage. Curves A, 0.025-mm-thick flyer; solid circle, computed velocity; open circle, step flasher data. Curves B, 0.051-mm-thick flyer; solid squares, computed velocity; open squares, step flasher data. Curves C, 0.127-mm-thick flyer; solid triangles, computed velocity; open triangle, step flasher data.

REFERENCES

1. R. C. Weingart, R. S. Lee, R. K. Jackson, and N. L. Parker, "Acceleration of Thin Flyers by Exploding Metal Foils: Application to Initiation Studies," Sixth Symposium (International) on Detonation, Preprints, p. 201 (August 1976).
2. R. W. Gurney, "The Initial Velocity of Fragments from Bombs, Shells and Grenades," Ballistic Research Laboratory report No. 405 (September 1943).
3. I. G. Henry, "The Gurney Formula and Related Approximations for High Explosive Deployment of Fragments," Hughes Aircraft Corp. report PUB-189 (April 1967).
4. M. Defourneaux, "Transport of Energy in Combustions and Detonations with Confinement," *Astronaut. Acta* 17, 609 (1972).
5. J. E. Kennedy and A. C. Schwarz, "Detonation Transfer by Flyer Plate Impact," Eighth Symposium on Explosives and Pyrotechnics, The Franklin Institute Research Laboratories, Philadelphia, PA (February 1974).
6. J. E. Kennedy, "Gurney Energy of Explosives: Estimation of the Velocity and Impulse Imparted to Driven Metal," Sandia Laboratories report SC-RR-70-790 (1970).

7. S. J. Jacobs, "The Gurney Formula: Variations on a Theme by Lagrange," Naval Ordnance Laboratory report No. 74-86 (June 1974).
8. J. Wackerle, "Applied Initiation Studies: Simple Considerations for the Design of Flying-Plate Initiation Systems," LASL Group WX-7 internal report (October 1974).
9. T. J. Tucker and P. L. Stanton, "Electrical Gurney Energy: A New Concept in Modeling of Energy Transfer from Electrically Exploded Conductors," Sandia Laboratories report SAND-75-0244 (1975).
10. T. J. Tucker and R. P. Toth, "The Electrical Behavior of Small Exploding Foil Flyer Assemblies," Sandia Laboratories report SAND-75-0445 (1975).
11. P. L. Stanton, "The Acceleration of Flyer Plates by Electrically Exploded Foils," Sandia Laboratories report SAND-75-0221 (1976).
12. *Handbook of Chemistry and Physics*, 51st Ed. (The Chemical Rubber Company, Cleveland, OH, 1970).
13. R. K. Jackson, Lawrence Livermore Laboratory, personal communication (November 1976).
14. W. C. Davis and B. G. Craig, "Smear Camera Technique for Free-Surface Velocity Measurement," *Rev. Sci. Instrum.* **32**, 579 (1961).