

LA-4208

DO NOT CIRCULATE

Retention Copy

C.1  
24

LOS ALAMOS SCIENTIFIC LABORATORY  
of the  
University of California  
LOS ALAMOS • NEW MEXICO

Reevaluated Critical Specifications  
of Some Los Alamos Fast-Neutron Systems

LOS ALAMOS NATIONAL LABORATORY



3 9338 00368 8776

UNITED STATES  
ATOMIC ENERGY COMMISSION  
CONTRACT W-7405-ENG. 36

## LEGAL NOTICE

This report was prepared as an account of Government sponsored work. Neither the United States, nor the Commission, nor any person acting on behalf of the Commission:

A. Makes any warranty or representation, expressed or implied, with respect to the accuracy, completeness, or usefulness of the information contained in this report, or that the use of any information, apparatus, method, or process disclosed in this report may not infringe privately owned rights; or

B. Assumes any liabilities with respect to the use of, or for damages resulting from the use of any information, apparatus, method, or process disclosed in this report.

As used in the above, "person acting on behalf of the Commission" includes any employee or contractor of the Commission, or employee of such contractor, to the extent that such employee or contractor of the Commission, or employee of such contractor prepares, disseminates, or provides access to, any information pursuant to his employment or contract with the Commission, or his employment with such contractor.

This report expresses the opinions of the author or authors and does not necessarily reflect the opinions or views of the Los Alamos Scientific Laboratory.

Printed in the United States of America. Available from  
Clearinghouse for Federal Scientific and Technical Information  
National Bureau of Standards, U. S. Department of Commerce  
Springfield, Virginia 22151

Price: Printed Copy \$3.00; Microfiche \$0.65

Written: June 1969  
Distributed: September 1969

LA-4208  
UC-46, CRITICALITY  
STUDIES  
TID-4500

LOS ALAMOS SCIENTIFIC LABORATORY  
of the  
University of California  
LOS ALAMOS • NEW MEXICO

Reevaluated Critical Specifications  
of Some Los Alamos Fast-Neutron Systems



*Gordon* by  
G. E. Hansen  
*ugh*  
H. C. Paxton

# REEVALUATED CRITICAL SPECIFICATIONS OF SOME LOS ALAMOS FAST-NEUTRON SYSTEMS

by

G. E. Hansen and H. C. Paxton

## ABSTRACT

The desire for more detailed critical specifications of Los Alamos fast-neutron assemblies than was required originally has led to the reevaluation of a number of published critical masses. In each case, there is idealization to the appropriate one-dimensional or two-dimensional representation. Minor changes of some published critical specifications result either from improvement of data upon which corrections are based or from more detailed accounting of component dimensions than was originally believed to be justified.

---

### Reasons for Reevaluation

During the decade or two after critical masses of Los Alamos fast-neutron systems were formulated, demands upon such data as check-points for calculations have become more stringent. In the early days, simplified one-dimensional representation was emphasized, and agreement of calculation within a percent or so was considered excellent. Now, with practical computational techniques for multidimensional systems, and refined cross-section sets, we have been asked for more detailed critical specifications than had been previously available. Users of the Monte Carlo method, in particular, have indicated a preference for uncorrected descriptions of critical systems.

As a result, we have reexamined the critical specifications of a number of fast assemblies that have most frequently been compared with calculation. In each case, however, there has been idealization to the appropriate one- or two-dimensional representation, because correction to such a form is usually no less certain than a more detailed description. The reason for this claim is that the principal uncertainty of interpreting a critical measurement is associated with dimensions that are known little better than to fabrication tolerances, which implies a significant uncertainty of effective density.

Corrections of the first few critical masses are treated

in sufficient detail to illustrate methods of handling and the resulting magnitudes. One purpose is to support the claim that these corrections do not necessarily imply a loss of accuracy. Another purpose is to explain minor changes of some critical mass values that have been published.<sup>1</sup> In brief, most of these changes result either from improvement of data upon which corrections are based, or from more detailed accounting of dimensions than was originally believed to be justified.

### Bare U(94) Critical Mass from Subcritical Measurement

Certain subcritical experiments have established critical conditions as precisely as can be done with the more versatile critical assemblies. The requirement is that it be possible to extrapolate from a high-multiplication assembly (say,  $M \geq 100$ ) to criticality while maintaining a well-defined geometry. Uncertainties introduced by the extrapolation may be no greater than those associated with corrections for control perturbations, sample cavities, etc., which are customary in assemblies designed for critical operation. Spheres, in particular, are usually perturbed less when intended for subcritical measurements than when used as critical assemblies.

The Bare Assembly. One of the better measurements of this sort was with a split-hemisphere assembly similar

in appearance to that of Fig. 1.<sup>2</sup> The objective was to establish the critical mass of U(94) for dimensioning the well-known Lady Godiva. The upper set of nesting U(94) hemispheres was supported by a diaphragm of 0.015-in.-thick stainless steel, and the lower set rested on a thin-wall aluminum cylinder. By remote control, the lower stack of hemispheres was raised to contact the diaphragm for each measurement of the multiplication of neutrons from a small near-central source. Observed linearity between reciprocal multiplication and sphere radius guided the extrapolation to criticality; duplicate measurements with a second diaphragm between hemispheres provided a means of correcting multiplication values to zero separation of the uranium halves.



Fig. 1. A Planet-machine setup with plutonium hemispheres in U(93) shells. The stainless-steel diaphragm supporting the upper part of the subcritical assembly is 0.015-in. thick.

The idealized final configuration, for which the multiplication was 143 (corrected to 193 for zero gap), is represented in Fig. 2. The indicated masses are for shell pairs, and the material density,  $18.806 \pm 0.008 \text{ g/cm}^3$ , is the average measured by liquid immersion for some of these shells and a number of similarly fabricated parts. Because masses and density are known more precisely than shell thicknesses, the radii shown were adjusted about nominal values to give proper shell volumes. The extrapolation to criticality (with diaphragm removed) is the equivalent of adding to the outside of the configuration of Fig. 2 a close-fitting 0.74-kg shell of U(93.86) at the average sphere density,  $18.66 \text{ g/cm}^3$ , for a total of 52.33 kg.

**Corrections.** Correction for a defect in the model with uniform shell spacing (Fig. 2), which results from lower hemispheres actually in contact as illustrated by

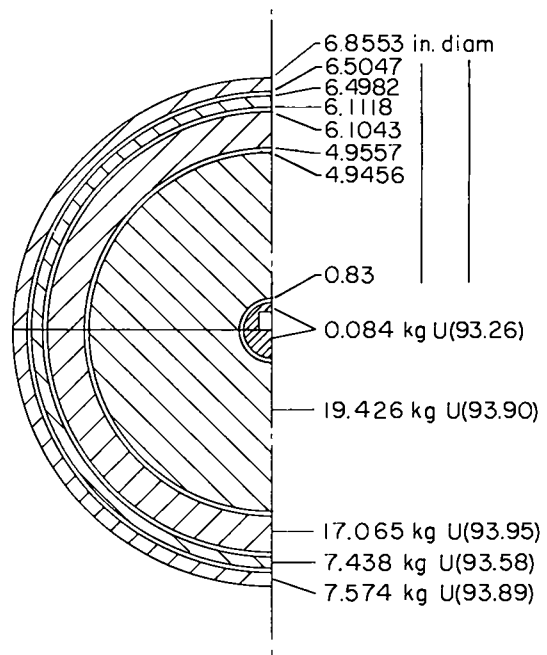

Material density  $18.806 \text{ g/cm}^3$

Fig. 2. Idealized final configuration of subcritical U(94) sphere.

Fig. 3, reduces this surface mass by 0.11 kg.\* Opposed to this change is a series of additions compensating for incidental reflection: +0.10 for the aluminum supporting cylinder and framework, estimated from effects of adding structures to other assemblies and checked by extrapolated reactivity-coefficient curves shown in Fig. 4;\*\* +0.04 kg for the Kiva walls as measured by moving Godiva outdoors, and +0.01 kg calculated for

\*Figure 3 exaggerates the nature of the model deficiency. Godiva reactivity coefficients for  $^{235}\text{U}$  and  $^{238}\text{U}$  as functions of radius<sup>3</sup> provide the basis for estimating the surface-mass effect of raising the two inner pieces so that they contact the diaphragm. The surface-mass equivalent of material added and subtracted to account for the shift of position is obtained by numerical integration. Uncertainties of dimensions justify no more than the first-order correction obtained by this process. In general, corrections for internal voids, for departures from spherical shape, and for structural or coating materials are obtained by similar integration.

\*\*Measured reactivity changes of these added structures agree reasonably well with results from numerical integration of extrapolated reactivity-coefficient curves over the structure volume. The extrapolation to large distances beyond the fissile surface, Fig. 4, connects observed curves smoothly with the  $r^{-4}$  "radar" relation that applies to objects of limited dimension (for extended surfaces such as walls and floor the reactivity effect is expected to depend upon the inverse square of the distance).

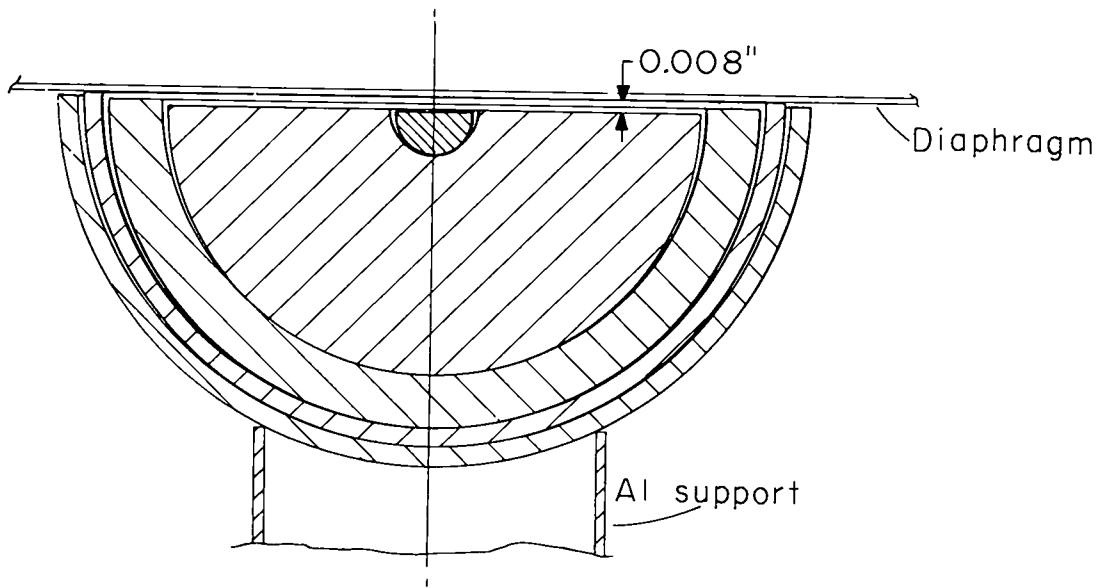

Fig. 3. Exaggerated defect of the shell model shown in Fig. 2; gaps on the parting plane are introduced by lower shells in contact.

atmospheric reflection. The net effect, an increase of the added shell mass to 0.78 kg, gives a total corrected critical mass of 52.37 kg uranium for the uniform shell model shown in Fig. 2.

**Critical Mass of Homogeneous Sphere.** The equivalent critical mass of a solid sphere at material density can now be obtained by using uranium reactivity coefficients to give the surface-mass reduction that would be equivalent to filling all voids of the described configuration. The result is a critical mass of 51.92 kg for a sphere of U(93.86) at a density of 18.80<sub>6</sub> g/cm<sup>3</sup>.

Uranium impurities were about 400 parts per million by weight, of which the major contributors were carbon (~160 ppm), silicon (~110 ppm), and iron (~70 ppm).<sup>\*</sup> Again, reactivity coefficients<sup>3</sup> show that the presence of the impurities decreases the critical mass 0.02<sub>3</sub> kg. Thus, for pure uranium, the critical mass becomes 51.94 kg, with density unchanged.

The uncertainty of the bare-sphere critical mass that has been deduced arises from the extrapolation to criticality and the described corrections. Expressed in terms of percent critical mass, these effects are:

Critical extrapolation	+(2.00 ± 0.20)%
Diaphragm correction	-(0.58 ± 0.06)%
Incidental reflection	+(0.29 ± 0.15)%

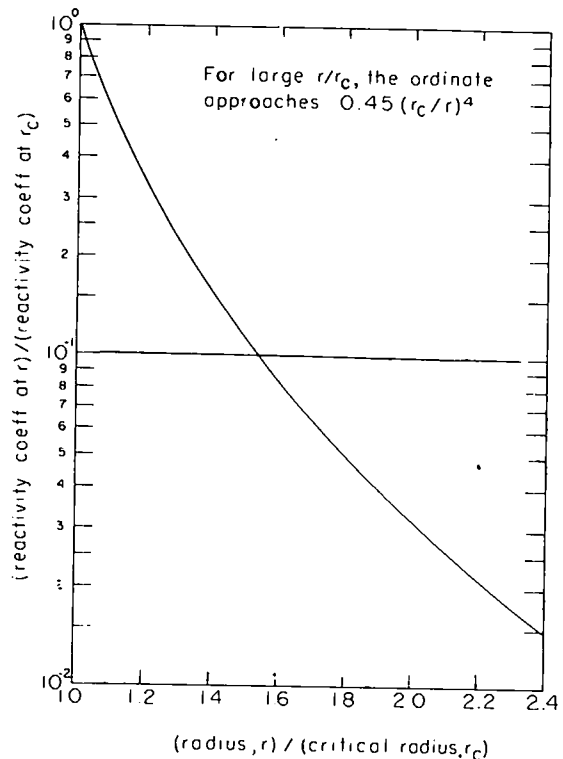

Fig. 4. Relative contributions of external material to the reactivity of a critical bare sphere. Measured values near the sphere surface connect smoothly with the  $r^{-4}$  relation that applies to objects of limited size at large distances  $r$ .

<sup>\*</sup>Presumably the shells, as well as parts of Lady Godiva, were of virgin material; where the metal is recycled, as for some recent components, impurities are usually about twice those shown.

Model defect	-(0.21 ± 0.07)%
Filling Voids	-(0.87 ± 0.17)%
Impurity removal	+(0.04 ± 0.00)%

Imprecision of the next-to-last item includes the unnamed source of error, i.e., uncertainty of shell description, so it seems reasonable to assign a probable error of ± 0.3% to the quoted critical mass for either the solid sphere or the shell model.

For the above account, all original corrections were reevaluated, and the resulting  $51.94 \pm 0.16$  kg U(93.86) at a density of 18.80<sub>6</sub> disagrees somewhat with the formerly published<sup>1,2</sup> critical mass of  $51.6 \pm 0.2$  kg for U(93.86) at a density rounded off to 18.81 g/cm<sup>3</sup>. The difference arises mainly because the earlier value was deduced from a crude average density estimate before reactivity coefficients and effects of incidental reflection were well established. Assumptions that the latter was negligible and that voids could be corrected as though they were uniformly distributed were not quite valid.

#### Bare U(94) Critical Mass from Godiva

Critical specification of a bare U(94) sphere had also been derived from Lady Godiva measurements before the best correction information existed. Consequently, revised corrections appear in the following account.

The most nearly spherical form of Lady Godiva consisted of the major parts identified in Fig. 1 of Ref. 2, essentially a 6.848-in.-diam sphere interrupted by a 0.100-in. cylindrical step in the upper portion and a 0.093-in. step in the lower section. With 14 mass-adjustment plugs (identified in the figure as "A" size) filling out the surface and with close-fitting glory-hole plugs inserted to achieve the most compact form, the total mass of U(93.71) was 52.905 kg.<sup>2</sup> This system was critical with one control rod retracted, and criticality was again achieved with control rods fully inserted and seven mass-adjustment plugs removed (0.343 kg at an average position slightly within the surface). From measured reactivity coefficients, however, it is now known that removal of these plugs is equivalent to the removal of 0.506 kg spread over the surface, or to shrinking the surface by 0.011 in.

Reactivity coefficients of Ref. 3 also provide a means of correcting for the effects of steel supports threaded into the Godiva body (+0.081 kg surface uranium) and for adjusting from the distorted sphere to a true sphere (-0.151 kg surface uranium). Compensation for incidental reflection by framework (from Fig. 4), the building (from outdoor measurement), and the atmosphere (computed) is estimated to add a further 0.073 kg. Like the shells, impurity correction adds 0.023 kg. The resulting critical mass is 52.42 kg for a sphere of U(93.71) at an average density now estimated to be 18.74 g/cm<sup>3</sup>. (The published<sup>2</sup> value, 18.71 g/cm<sup>3</sup>, was based on a nominal tally of voids and an assumed

material density of 18.79 instead of the 18.80<sub>6</sub> subsequently measured for similarly fabricated uranium parts. The value 18.73 g/cm<sup>3</sup> results from adjustment to the better material density, and the nominal envelope volume and enclosed mass give 18.75 g/cm<sup>3</sup>.) In this case, the uncertainty of critical mass arising from the outlined corrections and irreproducibility is about ± 0.2%. as compared with a similar probable error that should be associated with the uncertainty of average density and of void distribution. Again, an overall probable error of ± 0.3% is indicated. The new critical specification from Godiva,  $52.42 \text{ kg} \pm 0.3\%$  for a sphere of U(93.71) at an average density of 18.74 g/cm<sup>3</sup>, compares with a published<sup>2</sup> value  $52.25 \pm 0.1$  kg U(93.71) at an average density of 18.7<sub>1</sub> g/cm<sup>3</sup>.

**Comparison with Shell Results.** To intercompare these critical masses and those from the shell measurements, we note that the critical specification of a bare system can be converted to apply to any other density by means of the exact relation that critical mass is inversely proportional to the square of the density if shape is preserved. Further, adjustment for a moderate change of <sup>235</sup>U enrichment may be accomplished by the empirical expression that total critical mass is inversely proportional to the 1.72 power of the enrichment.<sup>3</sup> For a choice of 93.8% <sup>235</sup>U enrichment and 18.75 g/cm<sup>3</sup> density, these relations lead to the following critical masses:

	old	new
Lady Godiva	$51.9 \pm 0.1$ kg	$52.28 \pm 0.3\%$
shell experiment	$52.0 \pm 0.2$ kg	$52.31 \pm 0.3\%$

In other words, results of our reevaluation indicate that the early published values of bare-sphere critical masses for enriched uranium are 0.3 kg low. The new critical mass, however, differs from the old in that it applies to a truly isolated sphere of pure uranium.

To complete the specification of the uranium used for both sets of measurements, the <sup>234</sup>U content was 1.02 wt%, a value that is insensitive to few-percent differences of <sup>235</sup>U enrichment. Unlike some current enriched uranium, this old material contained no <sup>236</sup>U.

#### Jezebel Bare Spheres

Critical masses derived from the three Jezebel systems, Pu(4.5% <sup>240</sup>Pu), Pu(20% <sup>240</sup>Pu), and <sup>233</sup>U, were also reevaluated by means of the correction techniques that have been discussed. Results were somewhat greater than formerly published values for the Pu(4.5% <sup>240</sup>Pu) assembly<sup>4</sup> and for <sup>233</sup>U;<sup>5</sup> no value for Pu(20% <sup>240</sup>Pu) had appeared in the literature.

Unlike the U(94) assemblies, all Jezebel parts were coated with ~0.005-in.-thick nickel to prevent contamination by the highly α-active materials (see Fig. 5). Although nickel weights were known precisely, the distribution was uncertain. Consequently, uniform

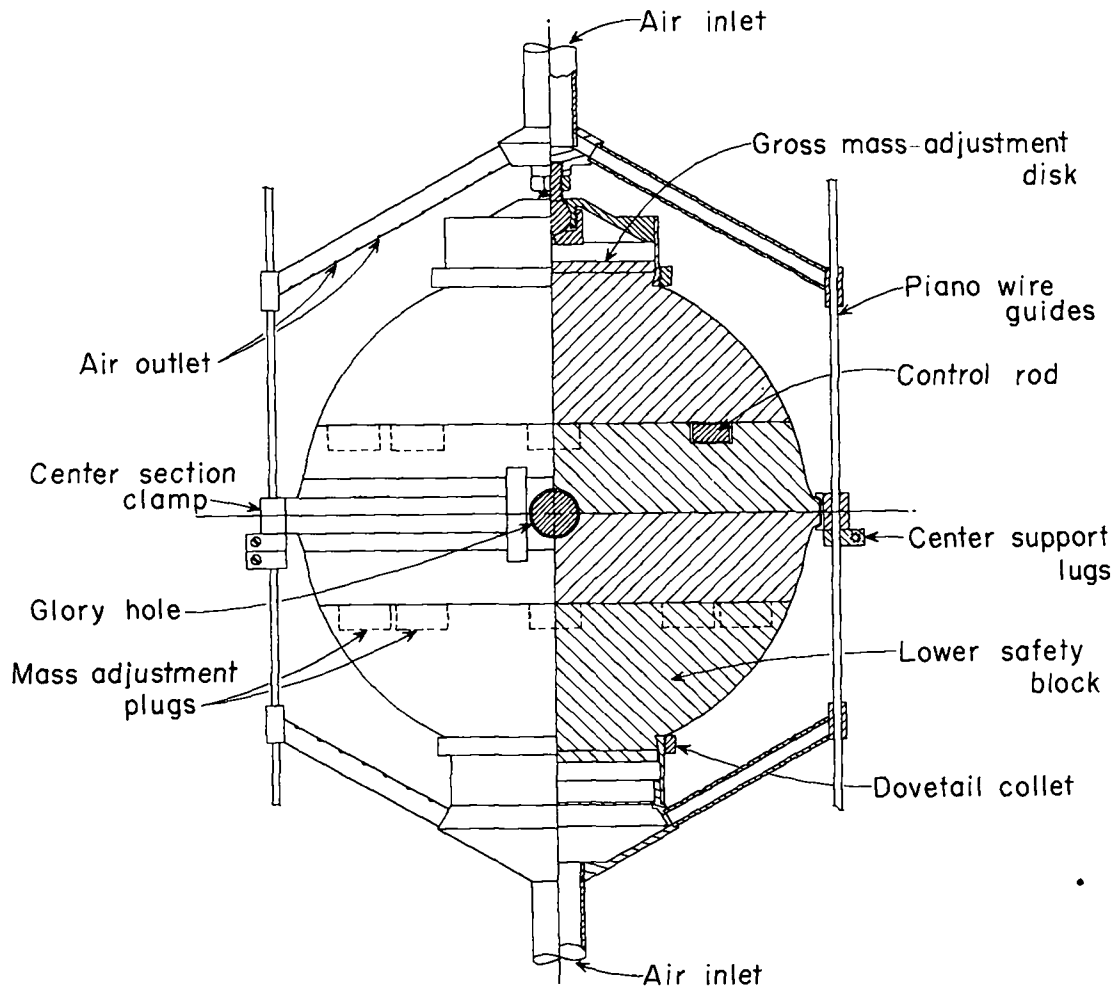

Fig. 5. The active portion of original Jezebel, the bare plutonium assembly. Cooling air blows out of the locating arms that ride on taut wires.

thickness was assumed in apportioning the nickel between external and internal surfaces. Lack of planeness, however, was assumed to introduce an average 0.001-in. gap between each of the three principal pairs of internal surfaces.

Average densities were established by adjusting measured material densities to allow for the nominal volume of internal nickel coating and voids. Voids remaining after correction for internal nickel were redistributed uniformly (with compensating surface-mass adjustment, Ref. 3) so that values of average density were retained.\*

\*A restatement of the inverse-square relationship between density and critical mass is that a given mass increment is three times as effective when distributed uniformly as it is when added to the surface.

As shown in Figs. 6, 7, and 8, the three Jezebel systems differed somewhat in shape, which led to different corrections for asphericity. Further, aluminum adapters required to fit the thin steel clamps (Fig. 5) to the small  $^{235}\text{U}$  parts added to the incidental reflection for that assembly. Otherwise, corrections were similar.

Captions of Figs. 6, 7, and 8 give the critical or slightly subcritical Jezebel configurations from which critical masses are derived. Also shown are corresponding masses corrected for the filling of major voids left by missing mass-adjustment plugs or glory-hole inserts, and by retracted control rod. These corrections rely upon calibrations of the control rod and plugs.

The further corrections for asphericity, nickel coating, incidental reflection by clamps and surroundings, homogenization, etc., are listed in Table I. The resulting critical masses apply to isolated bare spheres of uniform plutonium or uranium.



Table I. JEZEBEL CORRECTIONS TO IDEALIZED SPHERES

	<u>Pu(4.5% <sup>240</sup>Pu)</u>		<u>Pu(20% <sup>240</sup>Pu)</u>	<u><sup>233</sup>U</u>
	<u>Config. A</u>	<u>Config. B</u>		
Critical mass, kg <sup>a</sup> (Density, g/cm <sup>3</sup> )	16.761 (15.61)	16.784 (15.60)	19.173 (15.73)	16.25 <sub>2</sub> ±0.01 <sub>7</sub> , (18.42 <sub>4</sub> )
Corrections, kg:				
Asphericity	-0.033	-0.047	-0.063	-0.044
Internal Ni and homogenization	0.047 <sup>b</sup>	0.033 <sup>c</sup>	0.062	0.023
Equatorial band	0.045	0.045	0.058	0.110
Polar supports	0.117	0.117	0.145 <sup>d</sup>	0.108
External Ni	0.074	0.074	0.070	0.072
Framework	0.002	0.002	0.002	0.002
Kiva reflection	0.010	0.010	0.012	0.008
Air reflection	0.004	0.004	0.005	0.004
Trace impurities <sup>e</sup>	-0.001	-0.001	-0.001	0.000
Elevated temp.	-0.007	-0.007	-0.007	0.000
Critical mass of homogeneous sphere, kg alloy (Density, g alloy/cm <sup>3</sup> )	17.019 (15.61)	17.014 (15.61) 17.02±0.6% (15.61)	19.46±0.8% (15.73)	16.53±0.4% (18.42 <sub>4</sub> )

<sup>a</sup> Major cavities removed.

<sup>b</sup> Measured minus 144 g equivalent of 0.010-in.-thick Ni on one parting plane compares with calculated minus 142 g.

<sup>c</sup> Includes correction to  $\rho = 15.61 \text{ g/cm}^3$ .

<sup>d</sup> Measured 75 g equivalent of upper polar support compares with calculated 78 g.

<sup>e</sup> Pu impurities are about 600 ppm (170 ppm C, 230 ppm O, 115 ppm Fe); <sup>233</sup>U impurities are similar to those of Godiva.

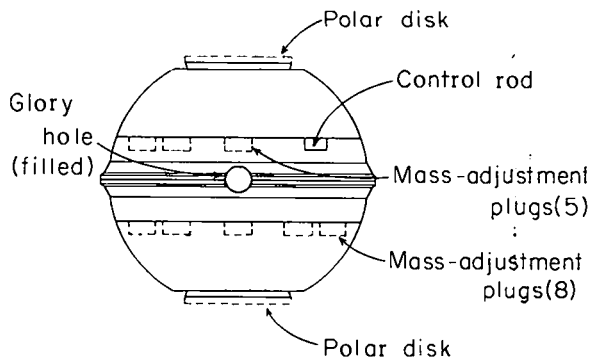

Fig. 6. Jezebel Pu (4.5%  $^{240}\text{Pu}$ ).  
Configuration A, 16.751 kg alloy:

no polar disk: subcritical 0.43 lower mass-adjustment plug (or 10 g alloy at surface) with all mass-adjustment plugs in place and control rod fully inserted; critical mass is 16.761 kg alloy at average density  $15.61 \text{ g/cm}^3$ .

Configuration B, 16.909 kg alloy:

two polar disks; critical with 6 lower mass-adjustment plugs removed, and control rod retracted 1.375 in.; with all mass-adjustment plugs in place and control rod fully inserted, critical mass is 16.784 kg alloy at average density  $15.60 \text{ g/cm}^3$ .

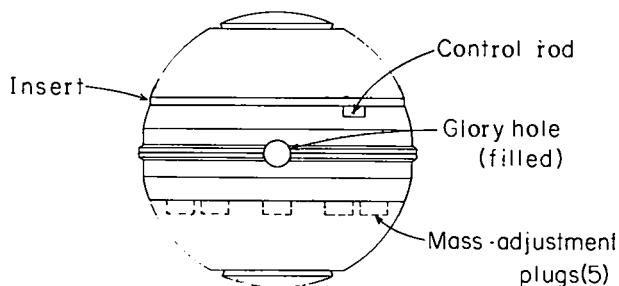

Fig. 7. Jezebel Pu (20%  $^{240}\text{Pu}$ ). Critical with insert in place, 5 lower mass-adjustment plugs removed, and control rod retracted 1.558 in., actual mass 19.369 kg alloy; with all mass-adjustment plugs in place and control rod fully inserted, critical mass is 19.173 kg alloy at average density  $15.73 \text{ g/cm}^3$ .

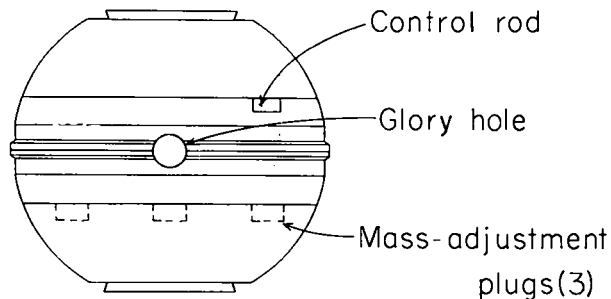

Fig. 8. Jezebel  $^{233}\text{U}$ .  
Configuration A, 16.556 kg uranium:

25 $\frac{1}{2}$  supercritical with 3 mass-adjustment plugs removed, 1.6-in.-long glory-hole filler removed from end, control rod fully inserted; with all mass-adjustment plugs in place and glory hole filled, critical mass is 16.235 kg uranium at average density  $18.424 \text{ g/cm}^3$ .

Configuration B, 16.651 kg uranium:

subcritical 1 $\frac{1}{2}$  with 0.015-in. equatorial gap, all mass-adjustment plugs in place, 0.5-in.-long cavity at glory-hole center, control rod fully inserted; with gap removed and glory hole filled, critical mass is 16.269 kg uranium at average density  $18.424 \text{ g/cm}^3$ .

Mean critical mass is  $16.25_2 \text{ kg uranium}$  at  $\bar{\rho}(\text{U}) = 18.42_4 \text{ g/cm}^3$ .

Quoted probable errors arise predominately from uncertainties of effective densities. The density of  $\delta$ -phase\* plutonium is much more variable than that of uranium, and the alpha heating interferes with precise measurement. The value for Pu (20%  $^{240}\text{Pu}$ ) was obtained from small samples that may not have been representative, whereas that for Pu (4.5%  $^{240}\text{Pu}$ ) is from major parts measured with a precision of  $\pm 0.2\%$  (equivalent to  $\pm 0.4\%$  of critical mass).

Critical specifications of isolated bare spheres, which were derived from Jezebel assemblies, may be summarized as follows.

\*Actually some  $\alpha$ -phase plutonium may be retained in these relatively large components.

Pu(4.5 at% <sup>240</sup>Pu, 0.3 at% <sup>241</sup>Pu), 1.02 wt% Ga:  
 $m_c(\text{alloy}) = 17.02 \text{ kg} \pm 0.6\%$  at  $\rho(\text{alloy}) = 15.61 \text{ g/cm}^3$ .

Pu(20.1 at% <sup>240</sup>Pu, 3.1 at% <sup>241</sup>Pu, 0.4 at% <sup>242</sup>Pu),  
 1.01 wt% Ga:  
 $m_c(\text{alloy}) = 19.46 \text{ kg} \pm 0.8\%$  at  $\rho(\text{alloy}) = 15.73 \text{ g/cm}^3$ .

U(98.13 at% <sup>233</sup>U, 1.24 at% <sup>234</sup>U, 0.03 at% <sup>235</sup>U,  
 0.60 at% <sup>238</sup>U):  
 $m_c(\text{U}) = 16.53 \text{ kg} \pm 0.4\%$  at  $\rho(\text{U}) = 18.42_4 \text{ g/cm}^3$ .

The critical mass of the first plutonium composition and of <sup>233</sup>U may be compared with earlier published values<sup>4,5</sup> by means of the simple density conversion that applies to bare systems. Both new values represent increases, as shown below.

	Critical mass total (kg)	
	<u>literature</u>	<u>revised</u>
Pu (4.5% <sup>240</sup> Pu), $\rho(\text{alloy}) = 15.82 \text{ g/cm}^3$ <sup>233</sup> U, $\rho(\text{U}) = 18.45 \text{ g/cm}^3$	$16.45 \pm 0.3\%$	$16.57 \pm 0.6\%$ $16.40 \pm 0.3\%$ $16.48 \pm 0.4\%$

#### Other Unreflected Systems

Among a large number of unreflected systems reported in a compilation "Los Alamos Critical-Mass Data",<sup>1</sup> only a few other examples are considered sufficiently precise or of general enough interest for inclusion here. Although that compilation includes no corrections for Kiva reflection, changes to account for this effect are generally small with respect to probable errors.

Nevertheless, the following illustrations are recorreced, to the best of our ability, for the influence of surroundings. For this purpose, we generalize the measured effect of Kiva reflection on Godiva to apply to assemblies of other shapes, sizes, and materials.\* Because

\*The expression used for effect of Kiva reflection on the geometric buckling of a bare assembly is

$$\frac{\Delta B^2}{B^2} = -0.72 \times 10^{-6} B^2 V_c \delta,$$

where  $\delta$  is the extrapolation distance and  $V_c$  is the critical volume. It was assumed that the fractional change of  $k$  is proportional to the leakage probability ( $P_L$ ), the surface area of the critical assembly ( $A_c$ ), and the ratio of the effectiveness of a neutron entering the assembly surface to that of the average neutron produced by fission ( $\gamma_s/\bar{\gamma}$ ), or

$$\frac{\Delta B^2}{B^2} = -\frac{1}{P_L} \frac{\delta k}{k} \propto A_c \gamma_s / \bar{\gamma}.$$

similar locations in a Kiva are assumed, results are only approximate.

**Spheres of  $\delta$ -Phase Plutonium and <sup>233</sup>U in U(93).**  
 Reported critical thicknesses of U(93) surrounding  $\delta$ -phase plutonium and <sup>233</sup>U spheres<sup>6</sup> made no allowance for reflection by a supporting cylinder, the assembly machine, or the Kiva. Because assemblies and mounts were like the subcritical U(94) sphere discussed earlier, it was assumed that surroundings contributed the same reflector saving (a relation approximated by the Kiva-reflection formula, for these small systems). The result, an increase of critical <sup>235</sup>U thickness by 0.003-in., leads to the following revised specifications.

Sphere of 8.471 kg Pu alloy, 4.9 at% <sup>240</sup>Pu, 0.31 at% <sup>241</sup>Pu, 1.0 wt% Ga,  $\rho(\text{alloy}) = 15.77_8 \text{ g/cm}^3$ ;  
 critical when surrounded intimately by U(93.2),  $\rho(\text{U}) = 18.80 \text{ g/cm}^3$ , at a thickness of 0.655 in.  $\pm 1\%$ .

Sphere of 7.601 kg U(98.2 wt% <sup>233</sup>U), 1.1 wt% <sup>234</sup>U, 0.7 wt% <sup>238</sup>U,  $\rho(\text{U}) = 18.64_4 \text{ g/cm}^3$ ;  
 critical when surrounded intimately by U(93.2),  $\rho(\text{U}) = 18.80 \text{ g/cm}^3$ , at a thickness of 0.783 in.  $\pm 1\%$ .

Sphere of 10.012 kg U(98.2 wt% <sup>233</sup>U), 1.1 wt% <sup>234</sup>U, 0.7 wt% <sup>238</sup>U,  $\rho(\text{U}) = 18.62_1 \text{ g/cm}^3$ ;  
 critical when surrounded intimately by U(93.2),  $\rho(\text{U}) = 18.80 \text{ g/cm}^3$ , at a thickness of 0.481 in.  $\pm 1\%$ .

Trace impurities, which are similar to those of Godiva and Jezebel materials, have negligible influence on these critical specifications.

**Cylinders of Mixed U(93) and Normal Uranium.** Two of the so-called Jemima critical assemblies can be described with reasonable precision.<sup>7</sup> Both are 10.50-in.-diam cylinders consisting of interleaved plates of U(93.4) (each 0.316-in. thick) and normal uranium (each 0.237-in. thick). Pairs of the two kinds of plates,

For critical cylinders, in which both flux and adjoint may be expressed as  $J_0(B_r r) \cos B_z z$ , we obtain the approximate relation

$$\gamma_s / \bar{\gamma} \propto V_c B^2 \delta / A_c.$$

a plausible form in that it is the ratio of extrapolation distance to a critical dimension  $A_c / V_c B^2$ . This gives the expression stated originally when the proportionality constant is evaluated from the measured effect of Kiva reflection on Godiva.

with U(94) at the base, led to a squat assembly for which the average  $^{235}\text{U}$  content was 53.3 wt%. For the other assembly (near-equilateral), which averaged 37.5 wt%  $^{235}\text{U}$ , each unit was a U(94) plate sandwiched between two normal plates (a "triplet").

Reported critical data were corrected for reflection by the principal support, but not for the effects of other parts of the assembly machine or of the Kiva. Correction for the remaining incidental reflection, estimated to be about 0.4%, is included in the following critical specifications.

Bare 10.50-in.-diam cylinder averaging U(53.33); critical mass 92.32 kg U(93.41) and 70.30 kg normal uranium as 10.97 plate pairs ( $\pm 0.5\%$ ), mean density  $18.83\text{ g/cm}^3$ .

Bare 10.50-in.-diam cylinder averaging U(37.46); critical mass 106.27 kg U(93.43) and 161.80 kg normal uranium as 12.63 plate triplets ( $\pm 0.5\%$ ), mean density  $18.88\text{ g/cm}^3$ .

The densities assigned here are about 0.7% greater than the estimated values quoted before. The present values are consistent with the nominal mass and volume of a stack of measured height, also with the material density given earlier for U(94) shells when adjusted by the ratio of nominal to measured stack heights.

Other bare cylindrical assemblies listed in the compilation of Los Alamos data<sup>1</sup> consist of  $\sim 3$ -mm-thick U(93) plates interleaved with plates of a number of other materials. Significant warpage of the U(93) usually resulted in density uncertainties that overshadow corrections for reflection by Kiva and framework of the machine (corrections for supports have been incorporated). In general, critical masses vs U(93) content scatter from smooth curves by about  $\pm 1\%$ .

Not included in the compilation, are data reported by Chezem and Lozito<sup>8</sup> for bare 21.0-in.-diam uranium cylinders with average  $^{235}\text{U}$  contents of 16.01 wt%, 14.11 wt%, 12.32 wt%, and 10.90 wt%. Although the thin, somewhat warped, U(93) plates were mixed with normal uranium in these subcritical systems, careful measurements of stack heights established average densities reasonably well. Further, critical masses were corrected as well as possible for all incidental reflection. Thus, the data listed in Table II are consistent with published values.

### Reflected Assemblies

Those critical specifications of Los Alamos reflected assemblies which are most commonly used for checking

calculations have also been reexamined. The principal reason is to take into account, as well as possible, the clearances between components such as core and reflector. The presence of a reflector, of course, reduces the influence of incidental reflection upon core size.

**Spheres of U(93), Plutonium, and  $^{233}\text{U}$  in Thick Uranium.** Critical masses reported for the Flattop assemblies<sup>5</sup> have been modified slightly to include the effect of a 0.004-in. to 0.005-in. gap between cores and reflector. The three cores were reflected by 19.00-in.-diam normal uranium at a density of  $19.0\text{ g/cm}^3$ . Critical masses are:

$17.84 \pm 0.04\text{ kg U}(93.24)$  at the uranium density  $18.62\text{ g/cm}^3$  (reflector thickness 7.09 in.);

$6.06 \pm 0.03\text{ kg Pu alloy}$ , 4.80 wt%  $^{240}\text{Pu}$ , 0.30 wt%  $^{241}\text{Pu}$ , 1.10 wt% Ga, at the alloy density  $15.53\text{ g/cm}^3$  (reflector thickness 7.72 in.);

$5.74 \pm 0.03\text{ kg }^{233}\text{U}(98.13\text{ wt}\%)$ , 1.24 wt%  $^{234}\text{U}$ , 0.03 wt%  $^{235}\text{U}$ , 0.60 wt%  $^{238}\text{U}$ , at the uranium density  $18.42\text{ g/cm}^3$  (reflector thickness 7.84 in.).

**Some Other Reflected U(94) Spheres.** Critical configurations of a number of reflected U(94) spheres were established by subcritical measurements with split-reflector assemblies illustrated in Fig. 9. Unlike the bare subcritical assembly considered earlier (Figs. 1 and 2), no diaphragm complicated the pattern of gaps between hemispherical shells of core and reflector.

In particular, critical masses of U(94) reflected by 3.92-in., 1.76-in., and 0.70-in.-thick normal uranium have been quoted as precision values.<sup>1,9</sup> (A fourth member of this series is not considered here because the neutron multiplication attained is insufficient for reliable extrapolation to criticality.) The incentive for reexamination of these data is a subsequent generalization of reactivity coefficients\* which permits correction for effects of filling gaps within the core and between core and reflector. Sizes of gaps are estimated by adjusting nominal dimensions of shells to give consistency between masses and usual material densities. The revised specifications follow.

---

\*The generalization is a semiempirical scaling of void-coefficient distributions within U(94) cores, which provides a means of interpolating between the known distributions of Godiva and Topsy.

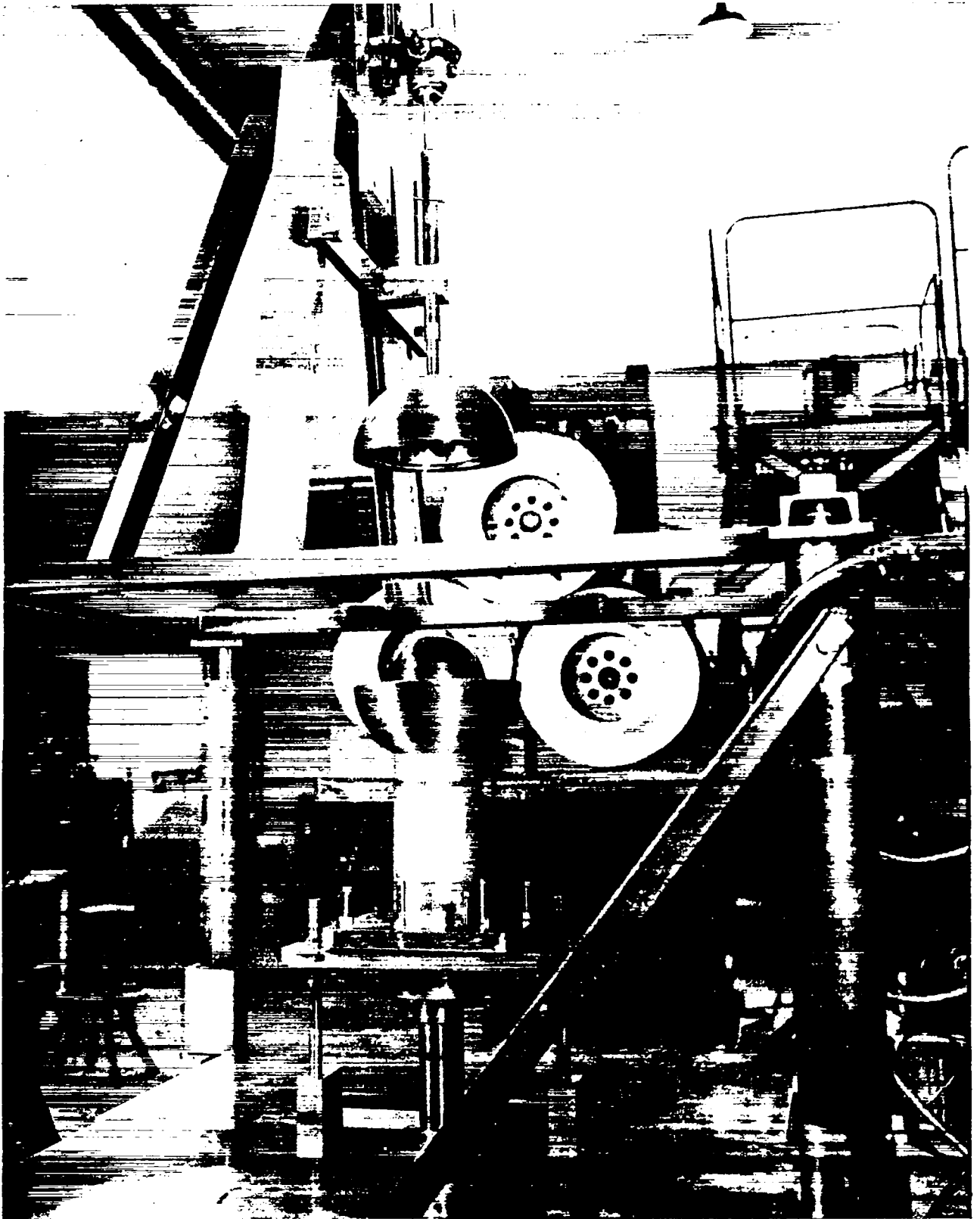

*Fig. 9. Set-up for subcritical experiments with reflected U(94) spheres; the entire core of spherical shells rests in the lower reflector hemisphere.*

Table II. CRITICAL SPECIFICATIONS OF 21.00-IN.-DIAM  
BARE CYLINDERS AVERAGING U(10.9) TO U(16.0)

Av. wt% <sup>235</sup> U	Nominal stack unit	Mass/unit, kg U	Av. density, g/cm <sup>3</sup>	Fraction crit. ht. attained	Critical mass, kg U
16.01	0.591-in.U(norm) 0.118-in.U(93.3)	76.1	18.68	0.965	1450±0.9%
14.11	0.709-in.U(norm) 0.118-in.U(93.3)	87.0	18.41	0.977	1828±0.7%
12.32	0.591-in.U(norm) 0.118-in.U(93.3)	100.4	18.64	0.983	2535±0.5%
10.90	0.236-in.U(norm) 0.709-in.U(norm) 0.118-in.U(93.3) 1.182-in.U(norm) 0.118-in.U(93.3)	224.8	18.63	0.764	4952±2.5%

In close-fitting 3.93-in.-thick normal uranium ( $\rho = 19.00 \text{ g/cm}^3$ ), the critical mass of a U(93.90) sphere at  $\rho(\text{U}) = 18.69 \text{ g/cm}^3$  is 19.82 kg U ± 0.5%.

In close-fitting 1.742-in.-thick normal uranium ( $\rho = 18.67 \text{ g/cm}^3$  because of gaps in reflector), the critical mass of a U(93.99) sphere at  $\rho(\text{U}) = 18.67 \text{ g/cm}^3$  is 26.56 kg U ± 0.5%.

In close-fitting 0.683-in.-thick normal uranium ( $\rho = 19.00 \text{ g/cm}^3$ ), the critical mass of a U(93.91) sphere at  $\rho(\text{U}) = 18.70 \text{ g/cm}^3$  is 36.53 kg U ± 0.5%.

Although there are differences in detail, these critical specifications are equivalent to the published data to within the quoted probable errors.

Other reflectors for which U(94) critical masses were established similarly are approximately 2-in. and 4-in. thicknesses of tungsten (90 wt%), zinc, copper, cast iron, graphite, beryllium, beryllium oxide, and nickel silver (40 wt% Cu, 32 wt% Ni, and 28 wt% Zn), and about 2-in. thicknesses of thorium and nickel.<sup>1,9</sup> Only the systems reflected by nickel and copper have been selected for review, the first because of an error in quoted density of nickel\* and the others to illustrate the influence of detailed accounting of gaps between shells, and of effective densities.

\*Another density error appears in Ref. 1, Item 2 of Table IC1, a thorium-reflected plutonium core. The thorium density should be  $11.58 \text{ g/cm}^3$ , instead of  $11.9 \text{ g/cm}^3$ .

In the new specifications that follow, there is no correction for trace impurities, which are similar to those of Godiva. The large error assigned to the first item is associated with a relatively low value of final multiplication.

Close-fitting "A" nickel reflector,  $\rho = 8.90 \text{ g/cm}^3$ , 1.945-in. thick: mass of critical U(93.8) sphere,  $\rho(\text{U}) = 18.38 \text{ g/cm}^3$ , is 29.27 kg ± 1.5%.

Close-fitting copper (99.92 wt%) reflector,  $\rho = 8.88 \text{ g/cm}^3$ , 1.980-in. thick: mass of critical U(93.8) sphere,  $\rho(\text{U}) = 18.38 \text{ g/cm}^3$ , is 28.14 kg ± 0.7%.

Close-fitting copper (99.92 wt%) reflector,  $\rho = 8.88 \text{ g/cm}^3$ , 4.158-in. thick: mass of critical U(94.0) sphere,  $\rho(\text{U}) = 18.43 \text{ g/cm}^3$ , is 22.17 kg ± 0.9%.

The results for copper reflectors, although differing in detail from published critical specifications, represent small overall changes. Effectively, the critical mass has been raised 0.1 kg for nominal 2-in.-thick copper, and 0.3 kg for ~ 4-in.-thick copper.

U(16) Cylinder in 3-in.-thick Normal Uranium. Analogous to the bare uranium cylinders of intermixed U(93) and normal uranium is a uranium-reflected

critical cylinder averaging about 16%  $^{235}\text{U}$ .<sup>1,10</sup> Like the bare systems, this assembly is reviewed for persons who wish to check two-dimensional computations. The 15.00-in.-diam core consists of alternating 0.589-in.-thick plates of normal uranium and 0.119<sub>5</sub>-in.-thick plates of U(93.35<sub>5</sub>), starting with normal uranium at the base. Thicknesses of normal uranium reflector are 3.00 in. on the base, 2.96 in. on top, and 2.99 in. on the lateral surface (adjusted slightly to eliminate a radial 0.007<sub>5</sub>-in. gap between core and reflector).

The average mass of a pair of normal and enriched plates is 38.90 kg and the composition averages U(16.19). The best value of critical number of pairs is 17.57 (vs 17.8 on which published specifications were based), which corresponds to a critical mass of 683 kg uranium at an estimated core density of 18.7<sub>5</sub> g/cm<sup>3</sup>. Uncertainty of the density value is the principal reason for assigning a probable error of  $\pm 0.5\%$  to the critical mass.

**High-Density Plutonium Sphere in Water.** A reliable value of the critical mass of an  $\alpha$ -phase plutonium sphere with water reflector was established by subcritical measurements after the compilation of Los Alamos data appeared.<sup>11</sup> A uniform sphere of high-purity material was prepared especially for this experiment and remachined for observing the effect of mass change. Perturbations from water displaced by a Plexiglas support (evaluated experimentally) and by a thin Plexiglas shell intimately surrounding the plutonium (evaluated by detailed computation) led to a 1.2% correction of critical mass. As indicated by constant neutron multiplication when the sphere was covered by more than 6 in. of water, the 10-in. minimum reflector thickness is effectively infinite.

The resulting critical mass, 5.79 kg  $\pm 0.5\%$ , applies to a water-reflected sphere of Pu(94.5 at%  $^{239}\text{Pu}$ ) for which the plutonium density is 19.74 g/cm<sup>3</sup> at 20°C. The remaining isotopic content is 5.18 at%  $^{240}\text{Pu}$ , 0.30 at%  $^{241}\text{Pu}$ , and 0.02 at%  $^{242}\text{Pu}$ . Detectable trace impurities, in parts per million by weight, are americium, 90; tungsten, 60; carbon, 25; oxygen, 20; silicon, 7; iron, 5; nickel, 4; nitrogen, 4; copper, 3; thorium, 3; magnesium, 1; gallium, 0.5; aluminum, 0.5; and manganese, 0.2.

## REFERENCES

1. H. C. Paxton, "Los Alamos Critical-Mass Data," USAEC Report LAMS-3067, Los Alamos Scientific Laboratory (May 1964).
2. R. E. Peterson, "Lady Godiva: An Unreflected Uranium-235 Critical Assembly," USAEC Report LA-1614, Los Alamos Scientific Laboratory (September 1953).
3. L. B. Engle, G. E. Hansen, and H. C. Paxton, "Reactivity Contributions of Various Materials in Topsy, Godiva, and Jezebel," Nucl. Sci. and Eng. **8**, 543-569 (1960).
4. G. A. Jarvis, G. A. Linenberger, J. D. Orndoff, and H. C. Paxton, "Two Plutonium-Metal Critical Assemblies," Nucl. Sci. and Eng. **8**, 525-531 (1960).
5. G. E. Hansen, "Status of Computational and Experimental Correlations for Los Alamos Fast-Neutron Critical Assemblies," *Physics of Fast and Intermediate Reactors*, **1**, 445-455, IAEA, Vienna (1962).
6. E. A. Plassmann and D. P. Wood, "Critical Reflector Thicknesses for Spherical  $U^{233}$  and  $Pu^{239}$  Systems," Nucl. Sci. and Eng. **8**, 615-620 (1960).
7. H. C. Paxton, "Bare Critical Assemblies of Oralloid at Intermediate Concentrations of U-235," USAEC Report LA-1671, Los Alamos Scientific Laboratory (May 1954).
8. C. G. Chezem and E. J. Lozito, "Investigation of the Criticality of Low-Enrichment Uranium Cylinders," Nucl. Sci. and Eng. **33**, 139 (1968).
9. G. E. Hansen, H. C. Paxton, and D. P. Wood, "Critical Masses of Oralloid in Thin Reflectors," USAEC Report LA-2203, Los Alamos Scientific Laboratory (July 1958).
10. J. J. Neuer, "Critical Assembly of Uranium Metal of an Average  $U^{235}$  Concentration of 16-1/4%," USAEC Report LA-2085, Los Alamos Scientific Laboratory (Jan. 1957).
11. D. R. Smith and W. U. Geer, "Critical Mass of a Water-Reflected Plutonium Sphere," to appear in Nuclear Applications.