

Nov. 24, 1964

R. J. REITHEL

3,158,098

LOW VOLTAGE DETONATOR SYSTEM

Filed Aug. 9, 1963

2 Sheets-Sheet 1

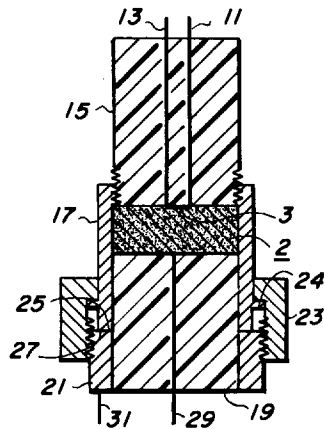

Fig. 1

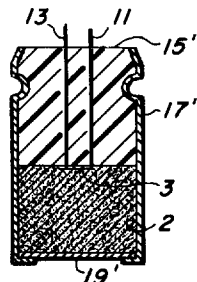

Fig. 1a

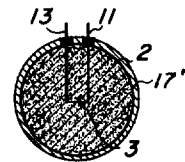

Fig. 1b

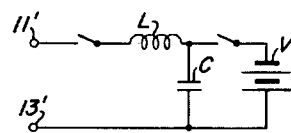

Fig. 6

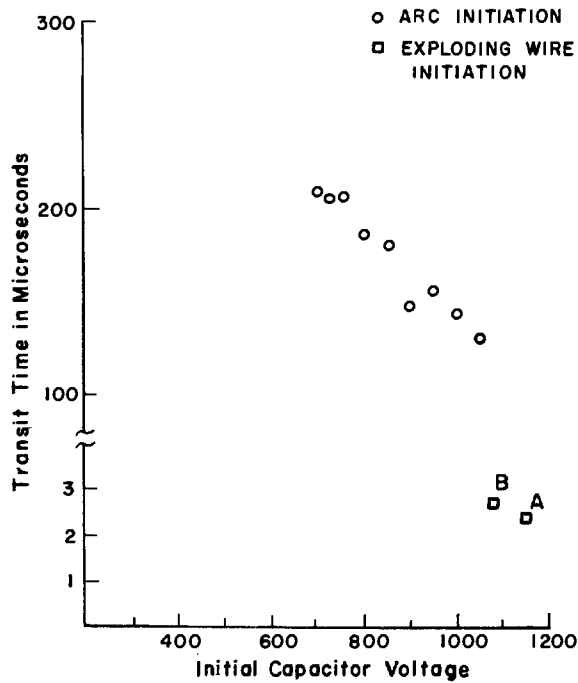

Fig. 2

INVENTOR.

Robert J. Reithel

BY

*Richard A. Goodson*  
Attorney

Nov. 24, 1964

R. J. REITHEL

3,158,098

LOW VOLTAGE DETONATOR SYSTEM

Filed Aug. 9, 1963

2 Sheets-Sheet 2

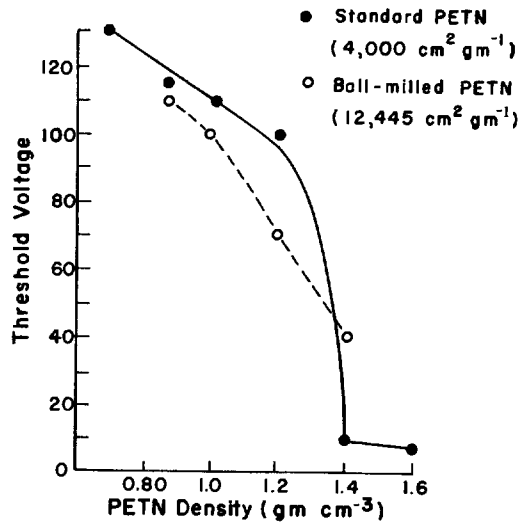

Fig. 3

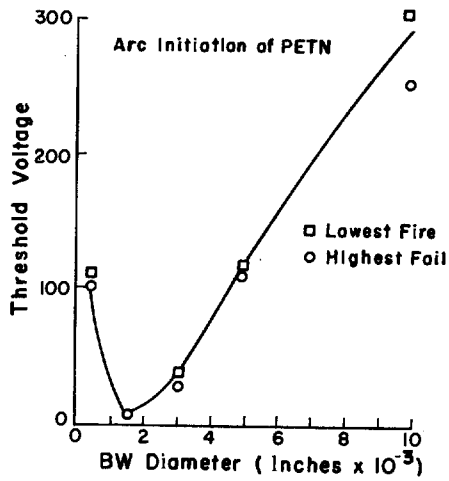

Fig. 4

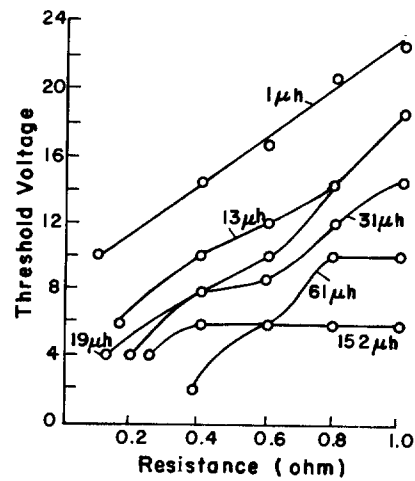

Fig. 5

INVENTOR.

Robert J. Reithel

BY

*Robert A. Groves*  
*Attorney*

1

3,158,098

## LOW VOLTAGE DETONATOR SYSTEM

Robert J. Reithel, Los Alamos, N. Mex., assignor to the United States of America as represented by the United States Atomic Energy Commission

Filed Aug. 9, 1963, Ser. No. 301,213

1 Claim. (Cl. 102-28)

This invention relates to detonators and detonation systems and more particularly detonation systems of the electric ignition type.

Electric detonators of explosives of the prior art are of several types. In one type a fuse wire is used which melts with the application of a relatively low voltage current. The fuse wire is embedded in a quantity of primary material such as mercury fulminate, lead azide, lead styphnate or the like. Adjacent to the primary material is the base charge which may be a high explosive substance, such as pentaerythritol tetranitrate (PETN) or trimethylene trinitramine (RDX), etc. The heating of the fuse wire by application of an electric current ignites the sensitive primary material which detonates the high explosive charge in the primary. This explosive in turn impresses a detonation or shock wave on the high explosive material to be fired. These initiators, generally termed squibs, are satisfactory for certain purposes but have serious disadvantages for other purposes. The sensitiveness of "igniting" explosives in general necessarily introduces hazards in manufacture and use, and these characteristics require elaborate precautions to ensure safety in handling. Mercury fulminate is well known to be thermally unstable, and has been replaced generally by lead azide. However, lead azide is susceptible to hydrolysis which, in the presence of copper, results in the formation of very sensitive corrosion products. Such detonators, consequently, have a very limited shelf life unless stored under closely controlled conditions. Lead styphnate is much more stable chemically but presents serious hazards due to its sensitiveness to electrostatic charges.

Secondary explosives, such as PETN, DATB, RDX, TETRYL, HMX and TNT, show much reduced orders of chemical sensitiveness, generally good chemical stability and in general very little hazard associated with electrostatic conditions. It follows, therefore, that a detonating system which contains only secondary explosive has great advantages over systems which combine primary and secondary explosives.

In another type of electrical detonator, a fuse wire is supported adjacent to the secondary explosive and is exploded by a sufficient electrical source such that the resulting shock is transmitted to and detonates the explosive.

It is an object of the present invention to provide a detonator containing secondary explosives only and which requires initiating voltages very low in comparison with those hitherto found necessary in the art.

The manner in which this and other objectives are obtained will become apparent from a reading of the following specification taken with the drawing in which:

FIGURE 1 is a longitudinal cross-sectional view of the detonator of the present invention arranged for test purposes.

FIGURE 1a is a cross-sectional view of the detonator of this invention in a suitable practicable form.

FIGURE 1b is a sectional view of another embodiment.

2

FIGURE 2 is a graph showing certain characteristics of detonators relative to firing voltage.

FIGURE 3 is a graph showing the relationship between the threshold firing voltage versus PETN density.

FIGURE 4 is a graph showing the relationship of threshold firing voltage relative to bridge wire diameter.

FIGURE 5 is a graph showing effect of inductance and resistance on firing threshold.

FIGURE 6 is a schematic showing an electrical firing circuit.

Referring to FIGURE 1, it is seen that the detonator of the present invention comprises a hermetically tight capsule 17 containing a dense explosive, such as PETN, 2, and a bridge wire 3 in contact with the explosive.

In greater detail, the detonator in accordance with the present invention comprises a pair of electrical connecting leads 11, 13 supported in and extending through insulator 15 and bridge wire 3 connected across the end of the leads.

Insulator 15 has a tight screw fit with internal threads in metal body member 17. The other end of metal body member 17 is closed by insulator member 19 and metal ferrule 21. Metal body member 17 has affixed thereto a protruding annular protrusion 24 which engages an inwardly directed shoulder on ring nut 23. The inner surface of ring nut 23 is threaded to engage exterior threads on ferrule 21. The abutting surfaces 25, 27 of body member 17 and ferrule 21 engage in a hermetic seal when ring nut 23 is tightened. The insulator member 19 is cemented in hermetic tight relationship inside ferrule 21. For investigative purposes, a pin switch wire 29 may be provided. Wire 29 penetrates insulator 19 and with wire 31 provides a complete circuit when ionized gas bridges the inner end of insulator 19 and body member 17.

In FIGURE 1a, the detonator consists simply of the secondary explosive material tightly confined in metallic body 17' with a substantial metal disc hermetically closing body 17'.

With this type of detonator and with PETN pressed to a density of 1.4 gm./cm.<sup>3</sup>, successful initiation has been obtained using as low as only 2 volts from a lead storage battery source. This voltage is of the order of that used to initiate commercial squibs and dynamite caps using primary explosives. It is apparent that the construction of such devices with PETN or other secondary type explosives rather than initiating mixtures such as lead azide or lead styphnate provides a great safety factor.

The present invention results from investigations of the effect on the firing voltage threshold of confining the explosive, the effect on the transit time of the burning of the explosive of varying the firing voltage, the effect of the density of the PETN on the firing voltage threshold, the effect on the firing voltage threshold of varying the bridge wire diameter, the ability to ignite other secondary explosives in this manner, the feasibility of initiating detonation in secondary explosives with a storage battery rather than the heretofore commonly used capacitor power supply and the feasibility of firing reduced quantities of PETN.

*Effect of hermetically confining the explosive.*—It is common practice to explode secondary explosives, such as PETN, by exploding a bridge wire adjacent the explosive material. Normally, it was understood in the art that there exists a definite threshold voltage requirement

3

to ignite any particular secondary explosive and, under this threshold value, an explosion could not be obtained. In the course of the investigation leading to the present invention it was noticed that a drastic lowering of the firing voltage threshold was obtained if the explosive material and the bridge wire were encapsulated in a strong, hermetically tight, detonation container and the bridge wire was heated until it parted. It is likely that the decomposition of the explosive adjacent the heated wire under conditions of sufficient pressure and the influence of arc conditions, including ultra-violet light, is the modus operandi of the ensuing detonation. Tests to determine the threshold pressure for arc initiation resulted in evidence that capsules containing PETN must be sufficiently strong to permit the decomposition products of the explosive to attain a value in the vicinity of the arc of about 525-600 pounds per square inch before the arc is extinguished. This strength may be provided by the material of the capsule or by the explosive, itself. Thus, if a sufficiently long and dense column of explosive were loaded into the capsule, the end may be left open and an explosion will still ensue. FIGURE 1b shows another configuration in which the explosive material 2 is confined in a spherical shell 17". The actual pressure which must be attained to insure the explosion depends on the particular explosive used.

It thus becomes apparent that the detonation of secondary explosives can be initiated by bridge wires by two entirely distinct phenomena. The utilization of a capacitor charged to a high voltage to explode the bridge wire results in prompt detonation. The detonation of PETN, when confined in a closed capsule in contact with a wire heated and parted by a low voltage, requires a much longer time and is apparently related to preheating and arc initiation.

*Transit time versus firing voltage.*—These conclusions are borne out by the results of an investigation of the effect of different firing voltages on transit time. The transit time of burning is measured by utilizing a pin switch 29-31 at the end of the explosive mass remote from the initiating bridge wire and measuring the duration between the open circuiting of the initiating bridge wire and the signal from the pin switch. It is to be expected that if a pressure increase in the capsule due to heating by the bridge wire and/or by the arc established as the bridge wire parts is responsible for the lowering of the firing voltage threshold from that observed in normal exploding wire firings, that this process should require considerably more time than the normal two microseconds which elapses between the high voltage bursting of a bridge wire and the arrival of the ionized detonation front at the far end of the explosive mass.

A plurality of 0.88 gm./cm.<sup>3</sup> PETN pressings were encapsulated with a 0.0015 diameter and 0.040 length gold bridge wire in a hermetically tight cylindrical container of 0.300 inch diameter and 0.245 inch length. The electrical firing circuit had an inductance of 19 microhenries and a capacitance of 50 microfarads. The voltage applied to the bridge wire started at values below those capable of causing detonation and increased by increments. Table I, below, lists the voltages and transit times obtained. It should be noticed that the abrupt change from durations in the region of hundreds of microseconds to times in the region of a very few microseconds as the firing voltage exceeded 1050 volts confirms the conclusion that the initiation mechanism changes abruptly. Masses of PETN not encapsulated, i.e., not confined, subjected to voltages of 1075, and higher, detonated, while those subjected to voltages of 1050 and below failed. This established the fact that voltages sufficiently high to fire unconfined pressings resulted in the short transit times associated with normal exploding wire initiation of PETN. On the other hand, when the voltage was not sufficient to result in normal explosive behavior, only confined pressings exploded and involved transit times far longer

4

than those previously experienced with exploding wire initiation. Cathode-ray oscillograms responsive to the current through the bridge wire clearly established that the bridge wire parted in a few tens of microseconds, and that an arc then persisted between the electrodes until it was pinched off by the rapid increase in pressure accompanying the explosion. It appeared logical from the foregoing to interpret the initiating mechanism of the low voltage sort as "arc initiation" and that it consisted of applying a low voltage arc in close proximity to an explosive in a confined chamber until the pressure increased to a point where the burning of the hot explosive became self-propagating.

The data obtained from the foregoing experiments is tabulated in Table I.

TABLE I

Firing voltage:	Transit time <sup>1</sup> , (μsec.)
400	Fail
450	Fire
500	Fire
550	Fire
600	Fire
650	338
700	208
725	205
750	203
800	186
850	180
900	148
950	154
1000	144
1050	132
1075	2.7
1150	2.4

<sup>1</sup>Time is measured from the voltage spike of the bridge wire burst to the arrival of the ionization front of the PETN explosion at the pin switch electrodes. In those cases listed only as "fire," no pin switch signal was observed.

FIGURE 2 graphically shows the relationship between initial capacitor voltage and the reaction propagation speed in the explosive. Points A and B are short-time explosions and the lower value B, under the conditions of 50.2 microfarads of capacitance and 19.18 microhenries of inductance in the firing circuit, establishes a firing voltage of about 1050 and a propagation time of slightly less than 3 microseconds. No explosions are obtained with unconfined PETN below the value of about 1050 volts, whereas explosions can be obtained with voltages as low as 650 volts if the PETN is confined. It should be noted that these explosion characteristics are obtained with PETN having a density of 0.88 gm./cm.<sup>3</sup>.

*Effect of secondary explosive density on firing threshold.*—The effect of PETN density on the firing voltage threshold was investigated. A series of capsules containing PETN with densities ranging from 0.70 gm./cm.<sup>3</sup> to 1.6 gm./cm.<sup>3</sup> and with two specific surfaces of 4000 cm.<sup>2</sup>/gm. (standard) and 12,445 cm.<sup>2</sup>/gm. (ball milled) were fired by a firing unit as shown in FIGURE 6 having a capacitance C of 1330 microfarads and an inductance L of 19 microhenries. The firing circuit terminals 11' and 13' are adapted to connect to wires 11 and 13 of the detonators of FIGURES 1, 1a and 1b. Gold bridge wires 0.040 inch long by 0.0015 inch diameter were used. The data thus obtained is shown in Table II

TABLE II

PETN Density (gm./cm. <sup>3</sup> )	Threshold Voltage	
	Standard	Ball Milled
0.70	130	-----
0.88	115	110
1.0	110	100
1.2	100	70
1.4	9	40
1.6	8	-----

5

and is graphically shown in FIGURE 3. An unexpected conclusion results from this data in that, although PETN initiated in the "normal" manner by exploding wires requires a rapid rise of firing voltage threshold as the density of the explosive is increased, the opposite effect is obtained with the arc initiation technique.

Referring to FIGURE 3, the PETN of standard grind, i.e., 4000 cm.<sup>2</sup>/gm., required a threshold voltage extending from 130 volts at about 0.70 gm./cm.<sup>3</sup> to the low value of about 9 volts at a density of 1.6 gm./cm.<sup>3</sup>. It is noted that the two threshold voltages existing at 1.4 and 1.6 gm./cm.<sup>3</sup> are on a drastically flattened portion of the curve and this effect is probably accounted for by the fact that the 9 volts which fired the 1.4 gm./cm.<sup>3</sup> pressing was barely sufficient to part the bridge wire.

*Effect of pressure on arc ignition of PETN.*—The results of the experiments to determine the effect of hermetically confining the explosive, to determine the transit time as a function of firing voltage, and to determine the effect of the density of the pressed explosive on the firing voltage threshold indicate that, to insure an explosion, some critical pressure must be established in the explosive before the heat source (arc) is terminated. To measure this critical pressure, a length of tubing was substituted for the insulator, 19, of FIGURE 1. Nitrogen gas was introduced into the capsule by means of this tube. The PETN pressing had been previously tested to demonstrate that it was permeable. The gas, therefore, pressurized the entire volume of the explosive. An attempt was then made to explode the PETN by means of the electrically heated bridge wire and the subsequent arc formed when the wire parted. Two effects were noted. At gas pressures above about 525 to 600 pounds per square inch the explosive burned completely without any damage to the capsule or tube. At pressures of about 1400 pounds per square inch the capsule was shattered explosively. In the first case, since the volume of the gas tube was much larger than that of the capsule, the explosive was essentially unconfined. By the increase of pressure effected by the nitrogen gas the chemical reaction rate of the PETN was increased to the point that, once ignited by the hot wire and subsequent arc, the reaction of the PETN was self-propagating. In the second case the reaction rate was increased by the higher gas pressure to the point where detonation occurred within the explosive. The essential point in causing PETN to explode by arc ignition is, then, to provide a container which sufficiently impedes the flow of explosives decomposition products away from the heated region to develop the minimum pressure to insure that the reaction will become self-propagating before the heat source is removed. Once that condition is attained, the reaction will continue until the pressure developed explodes the capsule either by rupture by the pressure of decomposition products or, if the container is sufficiently strong, by detonation of the explosive. The pressure is, of course, a function of the particular explosive used.

Additional investigations to determine necessary confinement were made with the capsule of FIGURE 1a. This type capsule was filled with PETN to a depth of 0.245 inch at a density of 1.4 gm./cm.<sup>3</sup> and the unsupported closure disc area was varied. It was found that PETN would not explode by arc ignition if the aluminum foil thickness is 0.0005 inch and the unsupported diameter of the closure disc is 0.250 inch. On the other hand, if the strength of the confinement provided by the 0.0005 inch thick aluminum foil is increased by enlarging the area of the upset body flange and thus reducing the inner diameter of the annular ring to 0.199 inch, the PETN is explodable by arc ignition.

*Effect of bridge wire diameter on firing threshold.*—The effect of varying the bridge wire diameter was investigated with the results shown in Table III,

6

TABLE III

BW Diameter (inches)	Lowest Fire (volts)	Highest Fail (volts)
0.0005.....	110	100
0.0015.....	9	9
0.0031.....	40	30
0.0050.....	120	110
0.0100.....	300	250

and is graphically shown in FIGURE 4. The length of the bridge wire in all cases was 0.040 inch, the PETN density was 1.4 gm./cm.<sup>3</sup> and the specific surface was 4000 cm.<sup>2</sup>/gm. These results show that, for arc initiation by a firing circuit of 1330 microfarads capacitance and 19.18 microhenries inductance, the optimum diameter from the viewpoint of lowest voltage required is 0.0015 inch.

*Behavior of secondary explosives other than PETN.*—The foregoing results having been obtained with PETN, it became desirable to determine the behavior of other secondary explosives to the arc initiation process. The data is shown in Table IV which lists the firing threshold voltages obtained with the 1330 microfarad and 19 microhenry firing unit.

TABLE IV

Explosive	Specific Surface (cm. <sup>2</sup> /gm. <sup>-1</sup> )	Density (gm./cm. <sup>-3</sup> )	Firing Threshold (volts)
RDX.....	1,970	1.4	50
RDX.....	6,861	1.4	130
Tetryl.....	597	1.4	150
HMX.....	696	1.4	200
DATB.....	.....	1.4	270
TNT.....	2,302	1.4	175
Nitroguanidine.....	20,000	1.1	150
Nitromethane.....	(liquid)	1.1	150

The explosives (except for nitroguanidine and nitromethane which had a density of 1.1 gm./cm.<sup>3</sup>) were pressed to 1.4 gm./cm.<sup>3</sup> in the hermetic metallic capsules along with the 0.040 inch length and 0.0015 inch diameter gold bridge wire. The different explosives resulted in different damage to the capsules at threshold firing voltage. Firing was defined as disassembly of the capsule with a sharp report. PETN caused the greatest amount of damage. It invariably completely destroyed the plastic head on which the bridge wire was mounted and part of the metallic capsule. On the other hand, DATB simply pushed the plastic head out of the cylinder, damaging the plastic threads and tearing out a small portion of the threaded area of the brass cylinder in the process. Other explosives tore away all of the threaded portion of the brass cylinder while still others splayed the walls of the cylinder without cutting them. Even the liquid explosive, nitromethane, was successfully fired in this manner. It is conjectured that the different degrees of damage resulted from the fact that the encapsulation ruptured before the pressure in the explosive reached a sufficiently high value to cause the burning to go over into detonation in some of the cases and that the degree of damage is probably indicative of the extent to which this had occurred.

*Secondary explosives initiation using storage batteries.*—Low voltage initiation of encapsulated detonators was accomplished with storage batteries instead of the afore-described capacitor power sources. Results taking into consideration the effect of various resistances and inductances are shown in Table V.

**TABLE V**  
*The Effect of Inductance and Resistance on the Voltage Firing Threshold*

	Resistance (ohm)	Firing Threshold (volts)					
		1	13	19	31	61	152
Inductance (μh)-----	1.0-----	22.8	18.8	18.7	14.6	10.0	6.0
	.8-----	20.8	14.6	14.5	12.1	10.0	6.0
	.6-----	16.8	12.1	10.1	8.6	6.0	6.0
	.4-----	14.6	10.1	8.0	8.0	6.0	-----
	Minimum*	10.1	6.0	4.0	4.0	4.0	2.0
		(0.10)	(0.17)	(0.12)	(0.20)	(0.25)	(0.38)

\*The minimum circuit resistance for each inductance was attained by removing the piece of resistance wire which permitted adjustment of the circuit resistance to the desired steps. This value in ohms is enclosed in parentheses under each column.

It is seen that, although inductance lowers the firing voltage threshold, presumably by enhancing the ability to form an arc as the wire parts, it is not necessary to initiation. It is also seen that the firing threshold voltage increases with circuit resistance. The data in Table V was obtained with PETN having a density of 1.4 gm./cm.<sup>3</sup> in the capsule afore-described and with the 0.040 inch length and 0.0015 inch diameter gold bridge wire. The resistance of the circuit was obtained from a piece of No. 26 Chromel-C resistance wire in series in the circuit. This permitted the resistance of the circuit to be adjusted to the values shown.

*Reduced quantity of secondary explosive.*—Extremely minute quantities of secondary explosive material appear to be adequate for detonation provided the encapsulation is no larger than the charge. A layer of PETN of density 1.4 gm./cm.<sup>3</sup> only 0.035 inch thick fired at 10 volts which is substantially the same voltage determined applicable to a much larger piece.

The foregoing description of detonators utilizing only secondary explosives leads to the unexpected conclusions that hermetically encapsulating the secondary explosive in contact with a bridge wire permits the utilization of phenomenally low voltages for initiation. The presence of inductance in the firing circuit results in even further reduction in threshold voltage. In accordance with this invention, devices are provided which contain no primary explosives but which retain the advantage of low firing voltage hitherto only obtainable in devices containing primary explosives.

What is claimed is:

20 A secondary explosive detonator comprising a mass of PETN explosive material, an igniting gold metal bridge wire supported in contact with the explosive material, a firing circuit connected in series, electrically with said bridge wire, and means capable of withstanding an internal  
25 pressure of at least 550 pounds per square inch hermetically enclosing said mass of PETN and said bridge wire, said bridge wire having a length of 0.040 inch and a diameter of the order of 0.0015 inch, said PETN having a density of 1.6 grams per cubic centimeter, said firing circuit consisting of a direct current potential source having  
30 a potential of the order of 8 volts, a capacitor having a capacitance of the order of 1330 microfarads, and an inductance having a reactance of the order of 19 microhenries, means electrically connecting the capacitor in shunt with the potential source, means electrically connecting one terminal of the voltage source to one end of the inductance, means electrically connecting the other  
35 end of the inductance to one end of the bridge wire, and means including a switch electrically connecting the other end of the bridge wire to the other terminal of the potential source.

**References Cited in the file of this patent**

**UNITED STATES PATENTS**

45	2,981,186	Stresau -----	Apr. 25, 1961
	2,988,994	Fleischer et al. -----	June 20, 1961
	2,996,007	Franklin -----	Aug. 15, 1961
	3,040,660	Johnston -----	June 26, 1962